

THIS DRAWING IS UNPUBLISHED. RELEASED FOR PUBLICATION
 © COPYRIGHT BY TYCO ELECTRONICS CORPORATION. ALL RIGHTS RESERVED.

LOC	DIST	REVISIONS					
FT	0	P	LTR	DESCRIPTION	DATE	DWN	APVD
		0		REVISED PER 0G3B-1054-04	11/16/04	SS	SRY

NOTES:

MATERIAL:
 HOUSING: THERMOPLASTIC, UL94V-2.
 TERMINALS: BRASS, BRIGHT TIN PLATE.
 SCREWS: 6-32, STEEL, PLATED ZINC W/ CLEAR CHROMATE COATING. UNLESS OTHERWISE SPECIFIED.

ELECTRICAL:
 MAXIMUM CURRENT: 20A.
 OPERATING VOLTAGE: 600V.
 WIRE RANGE: 12-22 AWG.

ENVIRONMENTAL:
 OPERATING TEMP.: -60°C TO 105°C

▲ SCREWS ARE STAINLESS, BOTTOMED.

DIM A	NO. OF POS.	CATALOG NUMBER	PART NUMBER
11.937	27	SSB7TP270701	2-1546979-7
11.500	26	SSB7TP260701	2-1546979-6
11.062	25	SSB7TP250701	2-1546979-5
10.625	24	SSB7TP240701	2-1546979-4
10.187	23	SSB7TP230701	2-1546979-3
9.750	22	SSB7TP220701	2-1546979-2
9.312	21	SSB7TP210701	2-1546979-1
8.875	20	SSB7TP200701	2-1546979-0
8.437	19	SSB7TP190701	1-1546979-9
8.000	18	SSB7TP180701	1-1546979-8
7.562	17	SSB7TP170701	1-1546979-7
7.125	16	SSB7TP160701	2-1437417-2
6.687	15	SSB7TP150701	2-1437417-1
6.250	14	SSB7TP140701	1-1546979-4
5.812	13	SSB7TP130701	1-1437417-9
5.375	12	SSB7TP120701	1-1546979-2
4.937	11	SSB7TP110701	1-1546979-1
4.500	10	SSB7TP100701	1-1546979-0
4.062	9	SSB7TP090701	1546979-9
3.625	8	SSB7TP080701	1546979-8
▲ 3.187	7	SSB7TP070703	1-1437417-5
3.187	7	SSB7TP070701	1-1437417-4
2.750	6	SSB7TP060701	1-1437417-3
2.312	5	SSB7TP050701	1546979-5
1.875	4	SSB7TP040701	1546979-4
1.437	3	SSB7TP030701	1546979-3
1.000	2	SSB7TP020701	1546979-2

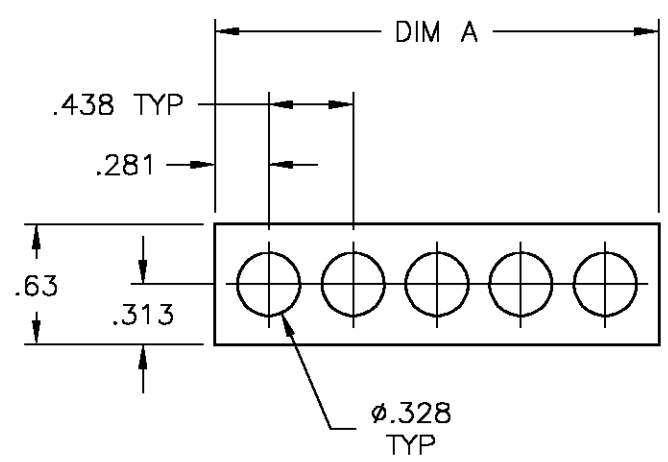
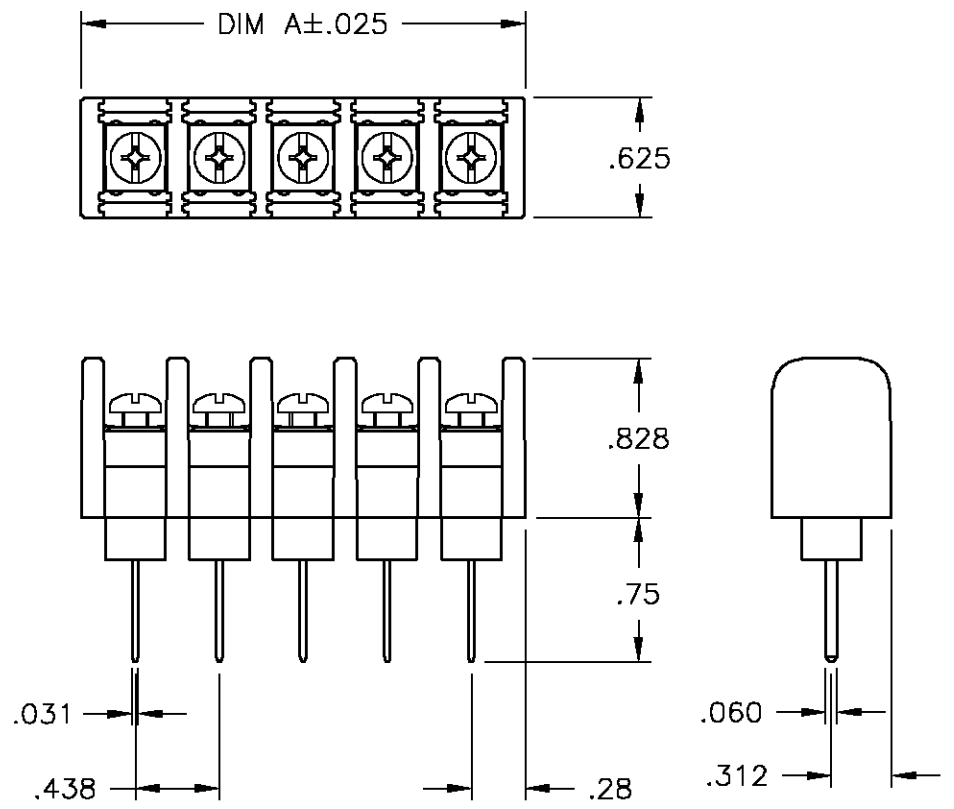

RECOMMENDED PANEL LAYOUT

THIS DRAWING IS A CONTROLLED DOCUMENT.		DWN S SCHLGEL 11/16/04	BUCHANAN Tyco Electronics Corporation Harrisburg, Pa 17105-3608	
DIMENSIONS: INCHES		CHK S YODER 11/16/04		
TOLERANCES UNLESS OTHERWISE SPECIFIED:		APVD S YODER 11/16/04	NAME SSB7TPXX0701	
0 PLC ± - 1 PLC ± - 2 PLC ± .02 3 PLC ± .010 4 PLC ± - ANGLES ± 1°		PRODUCT SPEC	RESTRICTED TO	
MATERIAL		APPLICATION SPEC	SIZE A3	CAGE CODE 00779
FINISH		WEIGHT -	DRAWING NO C-1-1437417-3	
CUSTOMER DRAWING			SCALE NTS	SHEET 1 OF 1
			REV 0	