

THIS DRAWING IS UNPUBLISHED. RELEASED FOR PUBLICATION
 © COPYRIGHT - BY TYCO ELECTRONICS CORPORATION. ALL RIGHTS RESERVED.

LOC	DIST	REVISIONS					
FT	0	P	LTR	DESCRIPTION	DATE	DWN	APVD
			A	-	8/18/06	SS	SRY

MATERIAL:
 HOUSING: THERMOPLASTIC, UL94V-2, BLACK.
 TERMINALS: BRASS, BRIGHT TIN PLATE.
 SCREWS: 6-32, STEEL, PLATED .0002 MIN ZINC W/
 CLEAR CHROMATE COATING. UNLESS OTHERWISE
 SPECIFIED.

ELECTRICAL:
 MAXIMUM CURRENT: 20A.
 OPERATING VOLTAGE: 600V.
 WIRE RANGE: 12-22 AWG.

ENVIRONMENTAL:
 OPERATING TEMP.: -60°C TO +105°C

11.937	25	SSB7TM250501	2-1776884-5
11.500	24	SSB7TM240501	2-1776884-4
11.062	23	SSB7TM230501	2-1776884-3
10.625	22	SSB7TM220501	2-1776884-2
10.187	21	SSB7TM210501	2-1776884-1
9.750	20	SSB7TM200501	2-1776884-0
9.312	19	SSB7TM190501	1-1776884-9
8.875	18	SSB7TM180501	1-1776884-8
8.437	17	SSB7TM170501	1-1776884-7
8.000	16	SSB7TM160501	1-1776884-6
7.562	15	SSB7TM150501	1-1776884-5
7.125	14	SSB7TM140501	1-1776884-4
6.687	13	SSB7TM130501	1-1776884-3
6.250	12	SSB7TM120501	1-1776884-2
5.812	11	SSB7TM110501	1-1776884-1
5.375	10	SSB7TM100501	1-1776884-0
4.937	9	SSB7TM090501	1776884-9
4.500	8	SSB7TM080501	1776884-8
4.062	7	SSB7TM070501	1776884-7
3.625	6	SSB7TM060501	1776884-6
3.187	5	SSB7TM050501	1546361-3
2.750	4	SSB7TM040501	1776884-4
2.312	3	SSB7TM030501	1776884-3
1.875	2	SSB7TM020501	1437417-5
1.437	1	SSB7TM010501	1776884-1
DIM A	NO. OF POS.	CATALOG NUMBER	PART NUMBER

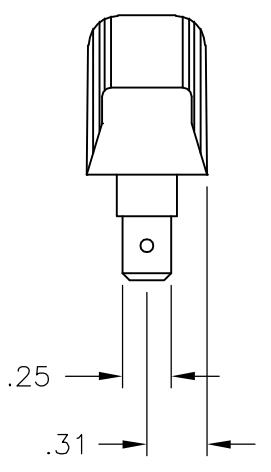
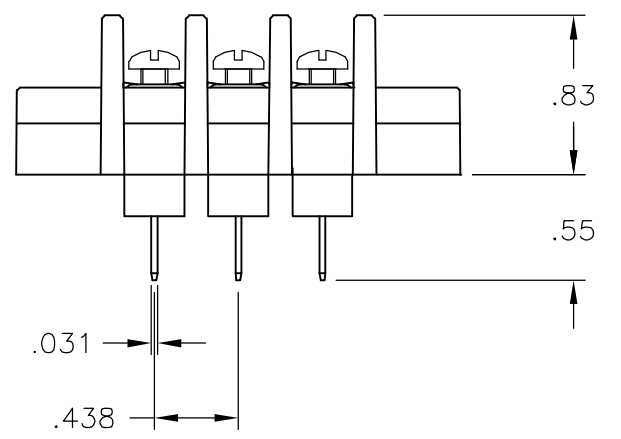
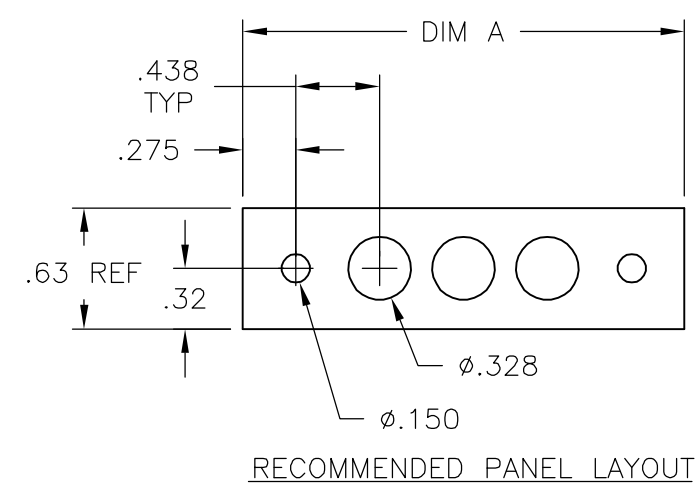
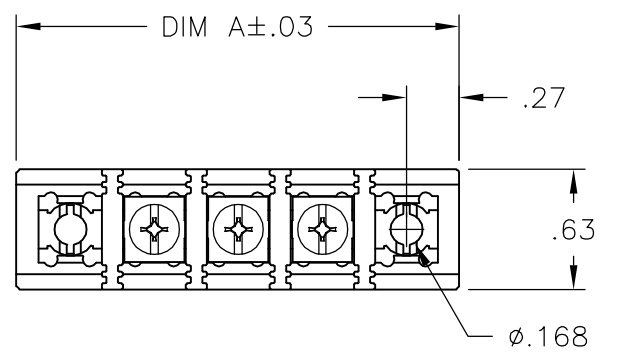

THIS DRAWING IS A CONTROLLED DOCUMENT.		DWN S SCHLGEL 8/18/06	BUCHANAN Tyco Electronics Corporation Harrisburg, Pa 17105-3608	
DIMENSIONS: INCHES		CHK S YODER 8/18/06		
TOLERANCES UNLESS OTHERWISE SPECIFIED:		APVD S YODER 8/18/06	NAME SSB7TMXX0501	
0 PLC ± -		PRODUCT SPEC -	SIZE CAGE CODE DRAWING NO RESTRICTED TO	
1 PLC ± -		APPLICATION SPEC -	A3 00779 C-1437417-5	
2 PLC ± .02		WEIGHT -	SCALE NTS SHEET 1 OF 1 REV A	
3 PLC ± .010		CUSTOMER DRAWING		
4 PLC ± -				
ANGLES ± 1°				
MATERIAL -				
FINISH -				