

THIS DRAWING IS UNPUBLISHED. RELEASED FOR PUBLICATION
 © COPYRIGHT BY TYCO ELECTRONICS CORPORATION. ALL RIGHTS RESERVED.

LOC	DIST	REVISIONS			
P	LTR	DESCRIPTION	DATE	DWN	APVD
G	86	A2	REVISED PER ECR-07-017744	30AUG07	HMR JR

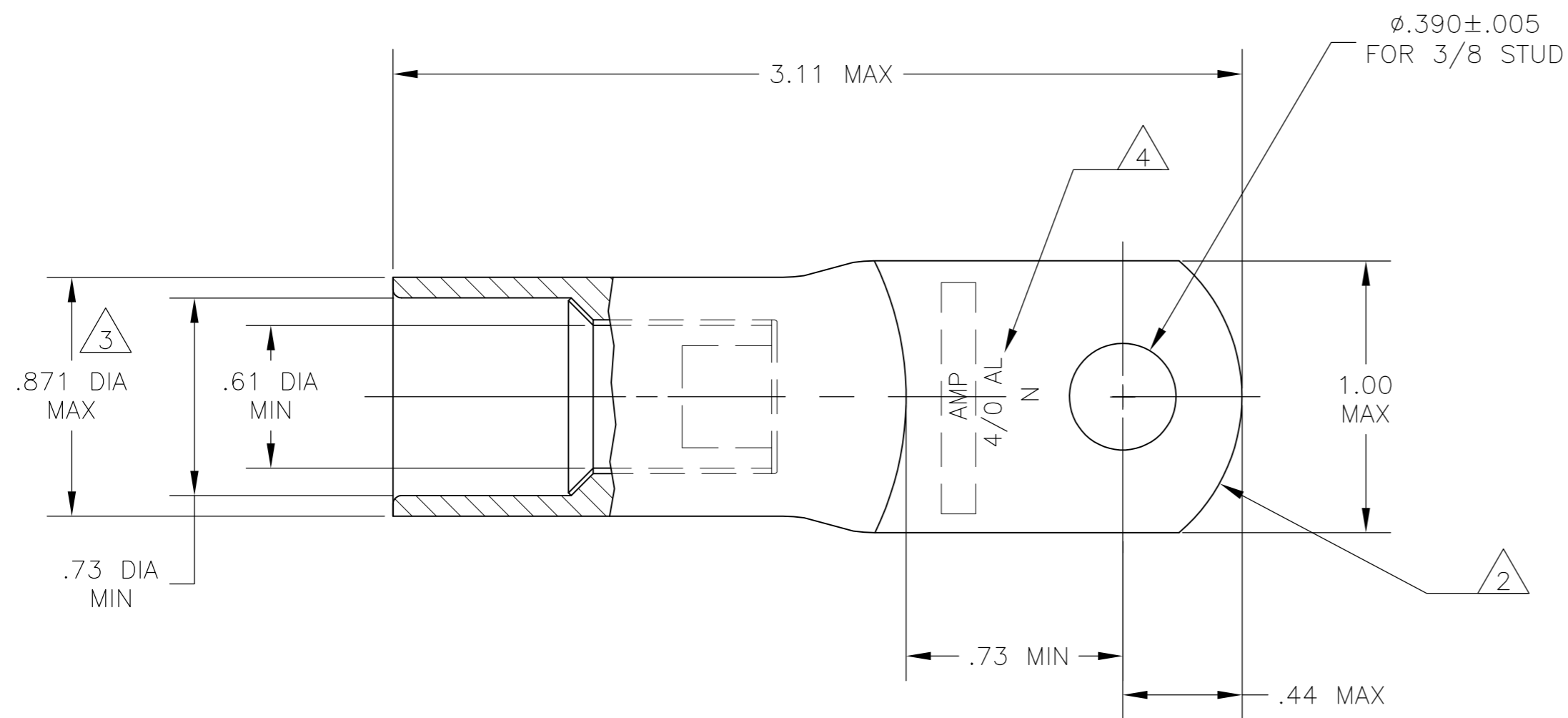

- 1 WIRE INSULATION: .590-.683 DIA
- 2 THE TONGUE RADIUS FEATURE IS NOT A TOOLING CONTROLLED DIMENSION AND MAY NOT BE A TRUE RADIUS.
- 3 FLASH PERMITTED ±.020
- 4 STAMP "AMP 4/0 AL N" SIZE AND LOCATION APPROX AS SHOWN SEE TABLE FOR QUALIFICATION PORTION OF STAMP P = PRODUCTION (IMPACT PART)
- 5 PREPRODUCTION - FASR REQUIRED
- 6 THIS PRODUCT HAS NOT COMPLETED VALIDATION TESTING

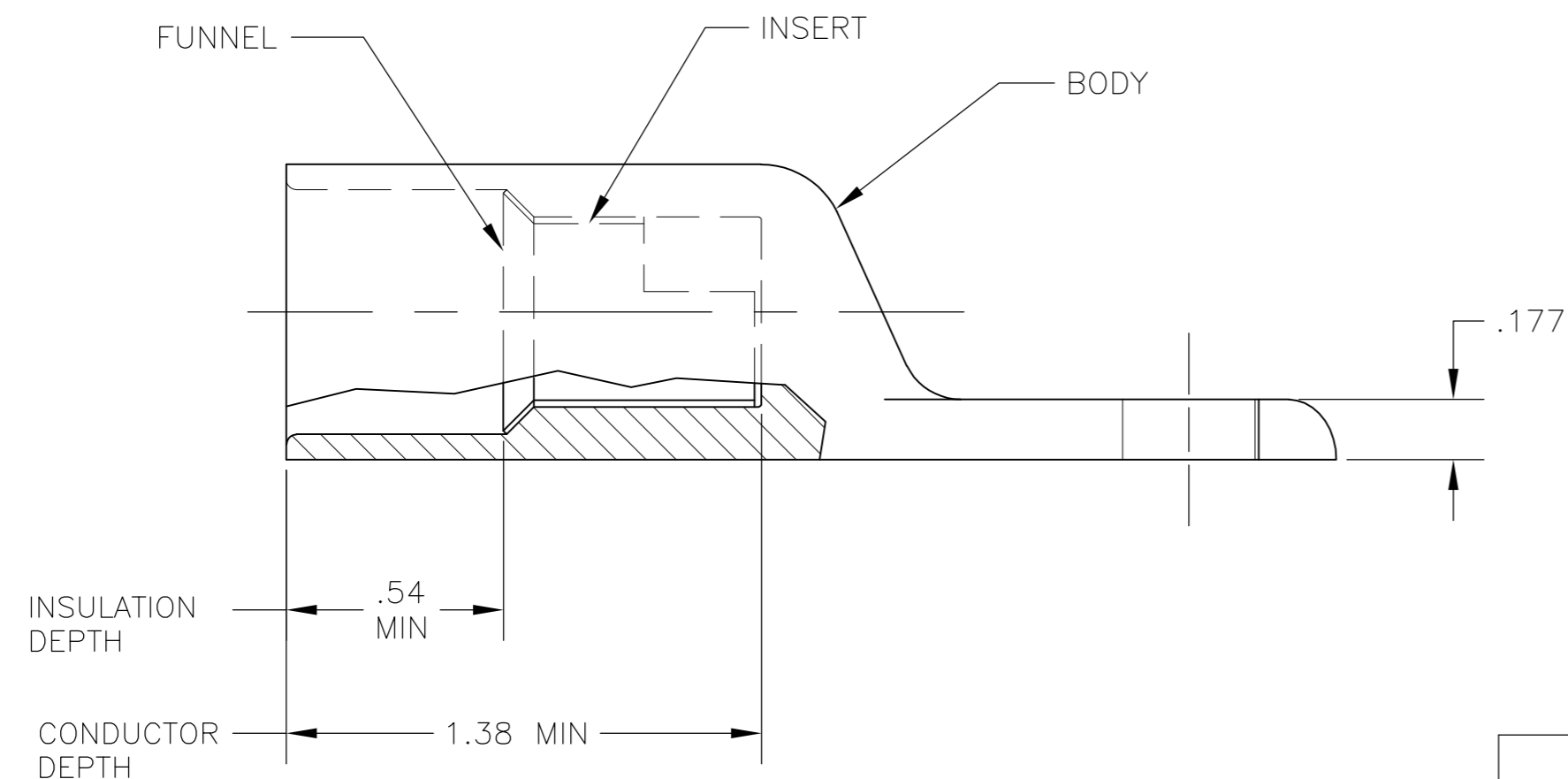

PRODUCTION	P AMP	INSERT & FUNNEL: BRASS MIL-C-50 NICKEL PL QQ-N-290 .000300 AVG THK	5 1958054-1
QUALIFICATION DESCRIPTION 4	QUALIFICATION STAMP 4	BODY: COPPER ASTM-B187 ANNEALED NICKEL PL .000300 MIN THK PER QQ-N-290	MATERIAL & FINISH
			PART NO.

THIS DRAWING IS A CONTROLLED DOCUMENT.		DWN jr ruth 08JAN07	Tyco Electronics Corporation Harrisburg, PA 17105-3608	
DIMENSIONS: INCHES		CHK JOHN KNOLL 08JAN07	NAME	
TOLERANCES UNLESS OTHERWISE SPECIFIED:		APVD JOHN KNOLL 08JAN07	PRODUCT SPEC	
0 PLC ± -		APPLICATION SPEC		
1 PLC ± -		WEIGHT 100 GRAMS		
2 PLC ± .01		SCALE 2:1		
3 PLC ± .008		SHEET 1 of 1		
4 PLC ± -		REV A2		
ANGLES ± -		CUSTOMER DRAWING		
FINISH		SIZE CAGE CODE DRAWING NO RESTRICTED TO		
SEE TABLE		A2 00779 C=1958054		