

THIS DRAWING IS UNPUBLISHED. RELEASED FOR PUBLICATION  
 © COPYRIGHT BY TYCO ELECTRONICS CORPORATION. ALL RIGHTS RESERVED.

LOC	DIST	REVISIONS					
		P	LTR	DESCRIPTION	DATE	DWN	APVD
G	14		P1	REV PER ECR 06-001832	22APR06	JR	TM

<b>AMP</b> WIRE RANGE	Listed	LR7189 Certified
12-10 AWG SOLID OR STRANDED	12-10 AWG SOLID OR STRANDED	12-10 AWG SOLID OR STRANDED

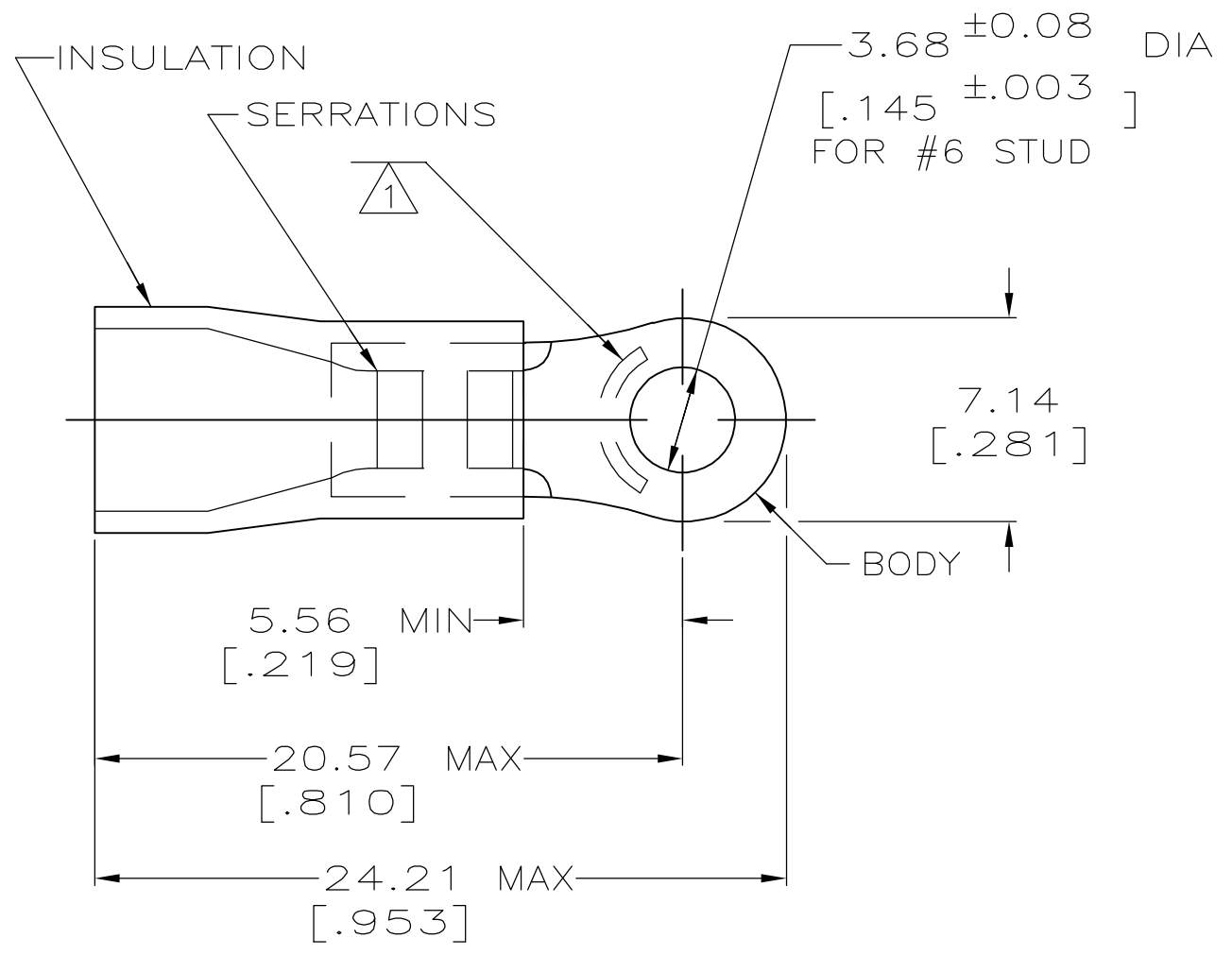

- △ 1 STAMP AMP 12-10\* APPROX AS SHOWN
- 2 WIRE INSULATION DIA: .150-.250
- 3 TONGUE MATERIAL THK: 0.99<sup>±0.05</sup> [.039<sup>±.002</sup>]
- △ 4 MATERIAL: BODY - CU PER ASTM B152  
SLEEVE - PVC, COLOR - YELLOW

QTY	PACKAGE TYPE	PART NO.
50	LOOSE PC,BOX	8-34852-2
2000	ON TAPE, REEL	2-34852-1
-	LOOSE PIECE	34852

<b>AMP INCORPORATED CUSTOMER SERVICE SYSTEMS</b>		MAX RECOMMENDED OPERATING TEMPERATURE: 105°C [221°F]	THIS DRAWING IS A CONTROLLED DOCUMENT.		DWN DK SCHRUM 08/06/92	Tyco Electronics Corporation Harrisburg, Pa 17105-3608			
FOR ADDITIONAL PRODUCT INFORMATION OR COPIES OF DRAWINGS AND TECHNICAL DOCUMENTS	PRODUCT INFORMATION CENTER 1-800-522-6752	VOLTAGE RATING: N/A	DIMENSIONS: MM [INCHES]	TOLERANCES UNLESS OTHERWISE SPECIFIED:	CHK RE HERSEY 11/10/92	NAME M BARNABA			
FOR APPLICATION TOOLING INFORMATION	TOOLING ASSISTANCE CENTER 1-800-722-1111	CIRCULAR MIL AREA: 2.62-6.64mm <sup>2</sup> [5,180-13,100] SOLID OR STRANDED		0 PLC ± - 1 PLC ± - 2 PLC ± 0.20[.008] 3 PLC ± - 4 PLC ± - ANGLES ± -	APVD M BARNABA 11/10/92	PRODUCT SPEC 108-1034			
FOR ORDER ENTRY	1-800-526-5142	THIS DRAWING IS A CONTROLLED DOCUMENT FOR AMP INCORPORATED. IT IS SUBJECT TO CHANGE AND THE CONTROLLING ENGINEERING ORGANIZATION SHOULD BE CONTACTED FOR THE LATEST REVISION.	MATERIAL - △ 4	FINISH TIN PER ASTM B545	APPLICATION SPEC NOT AVAILABLE	SIZE A3	CAGE CODE 00779	DRAWING NO C-34852	RESTRICTED TO -
CUSTOMER DRAWING					WEIGHT -	SCALE 4:1	SHEET 1 OF 1	REV P1	