

Current refinements (click  to remove)

[Search Tips](#) 
 [Region](#) **USA**  [Product Family](#) **Ring Terminal, Nylon Insulated**  [Text Search](#): 'PN14-6R-M'

**Your search criteria matched only one product, shown below.**

- Ring tongue design assures a secure connection in high vibration applications
- Metal insulation grip sleeve crimps to wire insulation, providing protection to the crimp joint during high vibration applications
- Internal barrel serrations assure good wire contact and maximum tensile strength
- UL Flammability UL 94V-2/HB, maximum insulation temperature 221°F (105°C)
- UL and CSA rated up to 600 V per UL 486

‡UL and CSA approved tooling/product combinations.

Note: Wire sizes #26 – #22 AWG, are not UL Listed or CSA Certified.

**Related Products**
[Hand Operated Plier Type Tools](#)
[Contour Crimp™ Control...](#)
[Pneumatic Crimping Tool](#)

Part Number:	PN14-6R-M
RoHS Compliancy Status:	Compliant
Part Description:	Ring Terminal, 18 – 14 AWG, #6 stud size, nylon insulated.
Product Type:	Terminals
CSA Certified:	Yes
Mil. Std. Part Number:	MS25036-107 (Class 1 & 2)
UL Listed:	Yes
Length (In.):	.85
Length (mm):	21.6
Width (In.):	.31
Width (mm):	7.87
Angle:	straight
Clearance:	.25
Max. Ins.:	.162
Panduit Color Code:	Blue
Stock:	.03
Stud Size:	#6
Tool:	CT-100A‡, CT-600-A‡, CT-1550‡, CT-1551‡, CT-2500‡
Wire Range:	18 – 14 AWG
Wire Range (mm <sup>2</sup> ):	4.0 - 6.0
Min. Order UOM:	PC
Min. Order Qty.:	1000
BOM Qty. (# of Pkgs.)	

[Add to My Catalog](#)

 Please [register](#) to utilize the 'Bill of Materials', 'Submit Quotes' and 'My Catalog' features.

PANDUIT PART NUMBER	PK	MILITARY PART NO. AND CLASS	STUD SIZE	DIMENSIONS in.				
				A $\pm .03$	W $\pm .01$	C $\pm .02$	G $\pm .03$	H $\pm .01$
PN14-4R	-C -M	MS25036-152 CLASS 1 & 2	#4	.78 (19.8)	.25 (6.4)	.20 (5.1)	.66 (16.8)	.12 (3.1)
PN14-6R	-C -M	MS25036-107 CLASS 1 & 2	#6	.85 (21.6)	.31 (7.9)	.25 (6.4)	.71 (18.0)	.15 (3.8)
PN14-6RN	-C -M	MS25036-106 CLASS 1 & 2	#6	.76 (19.3)	.25 (6.4)	.20 (5.1)	.63 (16.0)	.15 (3.8)
PN14-8R	-C -M	MS25036-153 CLASS 1 & 2	#8	.85 (21.6)	.31 (7.9)	.25 (6.4)	.68 (17.3)	.17 (4.3)
PN14-10R	-C -M	MS25036-108 CLASS 1 & 2	#10	.85 (21.6)	.31 (7.9)	.25 (6.4)	.68 (17.3)	.20 (5.1)
PN14-14R	-C -M	MS25036-154 CLASS 1 & 2	1/4"	1.05 (26.7)	.46 (11.7)	.38 (9.7)	.82 (20.8)	.27 (6.9)
PN14-56R	-C -M	MS25036-109 CLASS 1 & 2	5/16"	1.05 (26.7)	.46 (11.7)	.38 (9.7)	.82 (20.8)	.34 (8.6)
PN14-38R	-L -M	MS25036-110 CLASS 1 & 2	3/8"	1.14 (29.0)	.53 (13.5)	.43 (10.9)	.86 (21.8)	.40 (10.2)
PN14-12R	-L	-----	1/2"	1.35 (34.3)	.72 (18.3)	.53 (13.5)	.99 (25.1)	.52 (13.2)

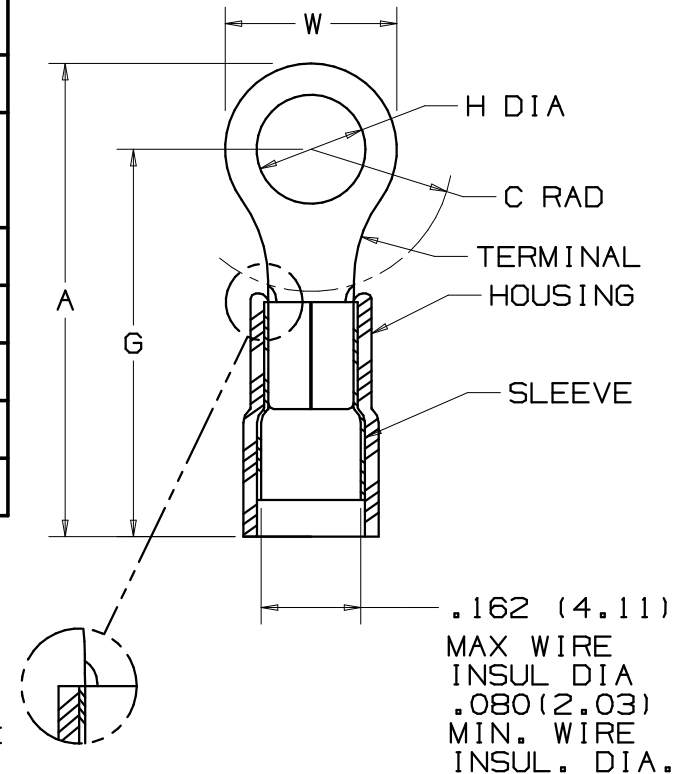

**NOTES:**

- UL LISTED AND CSA CERTIFIED FOR:
  - 600V. MAX. BLDG. WIRE (1000V. MAX. IN SIGNS, FIXTURES & LUMINARIES)
  - 221°F. (105°C) MAX. TEMP. RATING
  - #18-14 AWG SOLID OR STRANDED COPPER WIRE WITH THE CT-550, CT-1550, CT-1551, CT-460 (UL ONLY, AND MIL CLASS 2), CT-400 (UL ONLY, MIL CLASS 2) INSTALLATION TOOLS
  - #16-14 AWG SOLID OR STRANDED COPPER WIRE WITH THE CT-100 INSTALLATION TOOL
- MATERIAL:
  - STAMPING- .03" (.8) THK. COPPER, TIN PLATED
  - HOUSING- NYLON, BLUE
  - SLEEVE- BRASS, TIN PLATED
- WIRE STRIP LENGTH- 7/32" +1/32, -0 (5.6, +.8, -0)
- PACKAGE QUANTITY: -L = 50, -D = 500, -M = 1000
- DIMENSIONS IN PARENTHESIS ARE IN MILLIMETERS

Panduit part numbers shown on this drawing meet the material requirements of RoHS (EUROPEAN DIRECTIVES 2002/95/EC) as proposed by the Technical Adaptation Committee



A41185\_10

10	2/07	BCT	BCT	ADDED ALTERNATE SLEEVE / HOUSING DESIGN	TRO0214	LCA	TRO	TINLEY PARK, ILLINOIS  3PC. NYLON INSULATED, 16-14 BARREL, RINGS
09	8/06	DAW	DAW	ADDED MILITARY PART NO. & CLASS	TRO0155	LCA	TRO	
08	5/05	JHNU	SKB	REVISED NOTE 1 PER PRODUCT MANAGEMENT REQUEST.	12723	SKB	TRO	
07	12/02	SAC	SKB	FOR PN14-12R DIM A WAS 1.34 & DIM G WAS .98 & CHANGED ALL METRIC DIMS TO ONE PLACE	10504	LA	TRO	
REV	DATE	BY	CHK	DESCRIPTION	ECN #	CUST	PM	DRAWN BY: FES CHK'D: RLS SCALE: NONE DRAWING NO.: A41185