

REV.	DESCRIPTION	DATE
A	NEW DRAWING	12/19/2005
B	Added dimensions	4/3/2006
C	Updated material list	5/15/2006

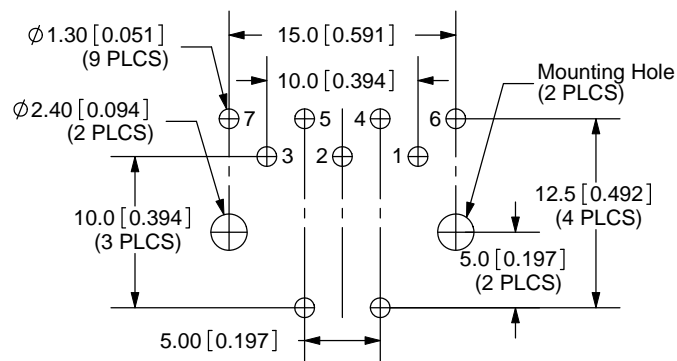
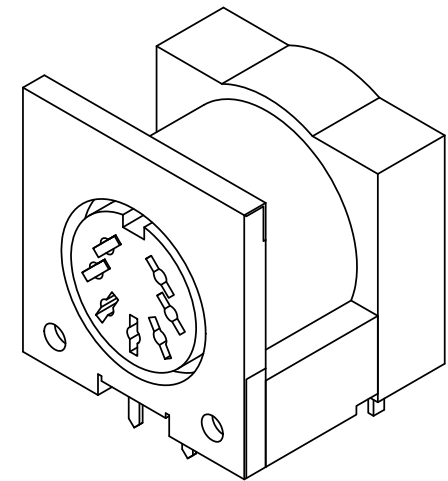
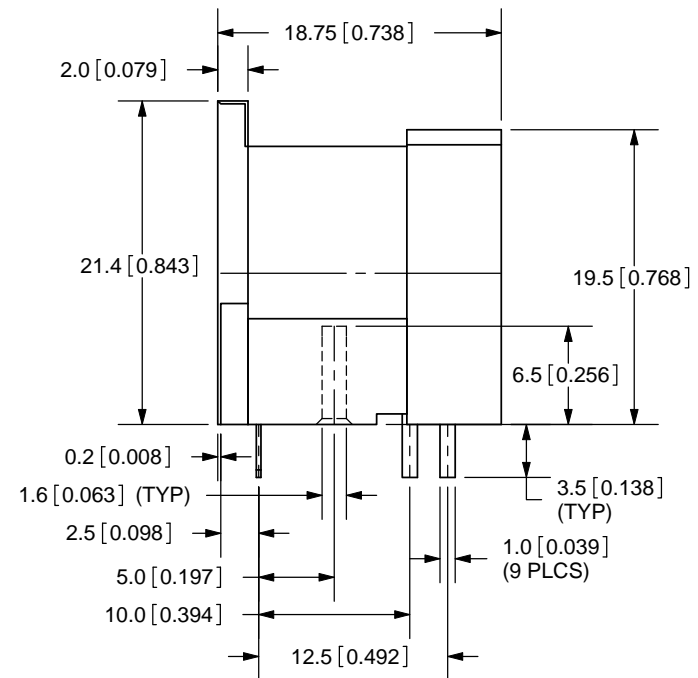
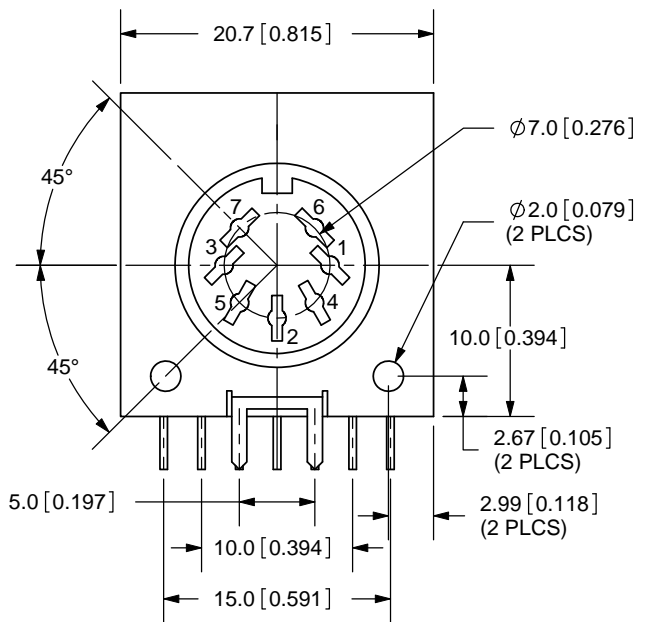

PCB LAYOUT  
TOP VIEW

**SPECIFICATIONS:**  
 RATING: 24V DC @ 1A; 100V AC @ 2A  
 CONTACT RESISTANCE: 20m OHMS MAX  
 INSULATION RESISTANCE: 100M OHMS MIN: 500V DC  
 VOLTAGE WITHSTAND: 500V AC R.M.S. FOR 1 MINUTE  
 INSERTION FORCE: 5.0KG MAX  
 WITHDRAWAL FORCE: 1.0KG~3.5KG  
 LIFE: 5,000 CYCLES  
 OPERATING TEMP: -40° ~ +85°C

TOLERANCE:  
 X.X ±0.2mm  
 X.XX ±0.1mm  
 X.XXX ±0.05mm



20050 SW 112th Ave.  
 Tualatin, OR 97062  
 Phone: 503-612-2300  
 800-275-4899  
 Fax: 503-612-2383  
 Website: www.cui.com

TITLE: STANDARD CIRCULAR CONN. w/ SHIELD		REV: C
PART NO. SDF-70J		UNITS: MM [INCHES]
DRAWN BY: ZRJ	APPROVED BY:	SCALE: 2:1

PC FILE NAME:  
SDF-70J

COPYRIGHT 2009 BY CUI INC.

	MATERIAL	PLATING
EARTH TERMINAL	Phosphor Bronze	Nickel
TERMINALS (1-7)	Brass	Tin
HOUSING	PBT	