

10 9 8 7 6 5 4 3 2 1

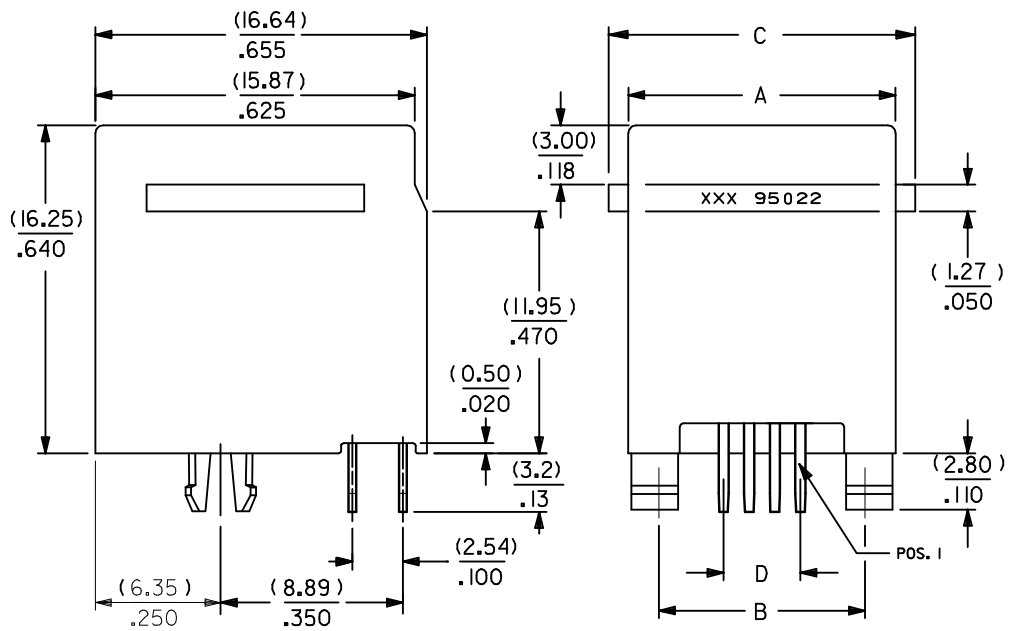
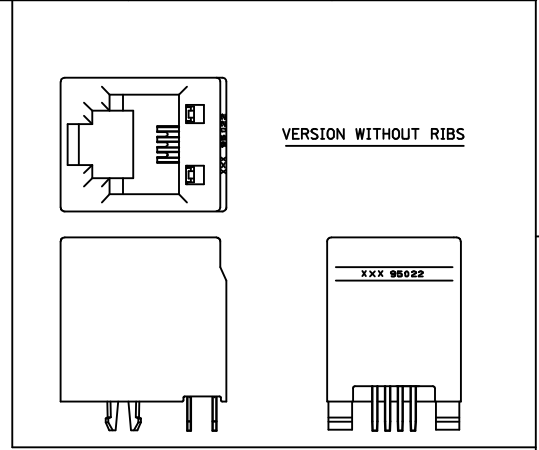
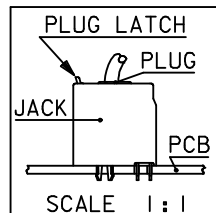
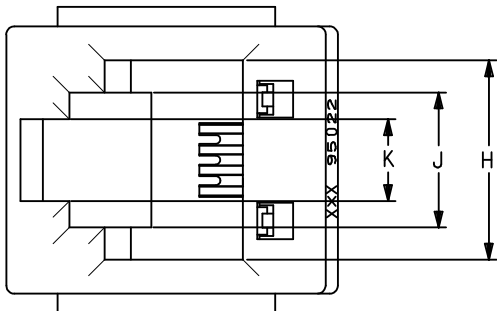

NOTES :

- 1- MATERIAL:
 - HOUSING: LCP FIBER GLASS FILLED 94-V-0 COLOR BLACK.
 - TERMINAL: BRASS FINISH 2
 - POST PLATE (0.00127-0.00152)/.000050-.000060 GOLD IN CONTACT AREA (0.00190)/.000075 MIN. PURE TIN IN TAIL AREA BOTH OVER (0.00127)/.000050 MIN. NICKEL OVERALL.
- 2- PC BOARD THICKNESS : (1.57) / .062 .
- 3- JACK FOR MATING WITH F.C.C. 68 PLUGS 90075 MOLEX SERIES .
- 4- PRODUCT SPECIFICATION PS-95522-001.
- 5- APPLICATION SPECIFICATION AS-85513-001
- 6- PACKAGING SPECIFICATION PK-95022. (SHT.1 TRAY PACKAGING) PK-95022. (SHT.2 TUBE PACKAGING)
- 7- FOR ILLUSTRATION PURPOSES A 4 CIRCUIT IS SHOWN.
- 8- PACKAGING SPECIFICATION RPK-95022-001 (TUBE PACKAGING).
- 9- MANUFACTURING I.D. CAN BE EITHER MG, MXF OR MXI.

ADDED PART No. EC NO: E2009-0420 DRWN: DBYRNES 2009/03/02 CHKD: 2009/03/06 APPR: J WALLACE 2009/03/09	DESCRIPTION QUALITY SYMBOLS ▽=0 ◻=0	GENERAL TOLERANCES (UNLESS SPECIFIED)		DIMENSION STYLE		SCALE	DESIGN UNITS	THIRD ANGLE PROJECTION			
				MM/IN		1:1	METRIC				
				mm	INCH	DRAWN BY	DATE	TITLE			
				4 PLACES ± ---	± ---	KNOLLER	04/08/27	HIGH PROFILE TOP ENTRY JACK			
		3 PLACES ± ---	± .010	CHECKED BY	DATE						
		2 PLACES ± 0.25	± .014	FCARABET	04/08/30	MOLEX INCORPORATED					
		1 PLACE ± 0.35	± ---	APPROVED BY	DATE						
		ANGULAR ± 2 °		KNOLLER	04/08/30	DOCUMENT NO.		SHEET NO.			
		DRAFT WHERE APPLICABLE MUST REMAIN WITHIN DIMENSIONS		MATERIAL NO. SEE CHART SHT. 2		SD-95522-001		1 OF 3			
				SIZE A3		THIS DRAWING CONTAINS INFORMATION THAT IS PROPRIETARY TO MOLEX INCORPORATED AND SHOULD NOT BE USED WITHOUT WRITTEN PERMISSION					

9 8 7 6 5 4 3 2 1

PART NUMBERS FOR JACK WITH RIBS									
TYPE	PACKAGING	POS. 4	TOOLED	POS. 6	TOOLED	POS. 6	TOOLED	POS. 8	TOOLED
		4 CKTS.		4 CKTS.		6 CKTS.		8 CKTS.	
FINISH 2	TRAY	95522-2447	X	95522-2647	X	95522-2667	X	95522-2887	X
	TUBE					95522-2617	X		
						SEE NOTE 8 SH.1			

PART NUMBERS FOR JACK WITHOUT RIBS									
TYPE	PACKAGING	POS. 4	TOOLED	POS. 6	TOOLED	POS. 6	TOOLED	POS. 8	TOOLED
		4 CKTS.		4 CKTS.		6 CKTS.		8 CKTS.	
FINISH 2	TRAY	95522-2441	X	95522-2641	X	95522-2661	X	95522-2881	X
	TUBE					95522-2611	X		

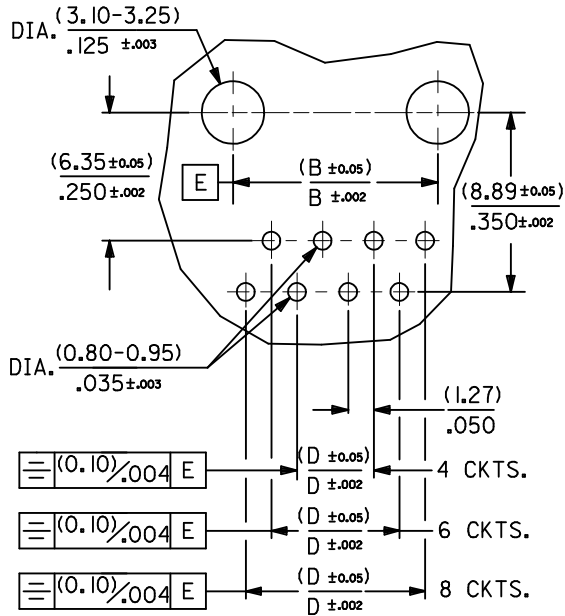

MOUNTING HOLE PATTERNS
(SEE FROM COMPONENT SIDE)

DIM.	TYPE	POS. 4	POS. 6		POS. 8
		4 CKTS.	4 CKTS.	6 CKTS.	8 CKTS.
A	(WITH RIBS)	(11.18) / .440	(13.21) / .520	(13.21) / .520	(15.24) / .600
B		(7.62) / .300	(10.16) / .400	(10.16) / .400	(11.43) / .450
C		(14.00) / .551	(16.00) / .630	(16.00) / .630	(18.00) / .709
D		(3.81) / .150	(3.81) / .150	(6.35) / .250	(8.89) / .350
H		(7.82) / .308	(9.88) / .389	(9.88) / .389	(11.94) / .470
J		(5.64) / .222	(6.70) / .264	(6.70) / .264	(6.30) / .248
K		(3.07) / .121	(4.06) / .160	(4.06) / .160	(4.06) / .160

ADDED 95522-2611 EC NO: E2009-0420 DRWN: DBYRNES 2009/03/02 CHKD: 2009/03/06 APPR: JWALLACE 2009/03/09	QUALITY SYMBOLS	GENERAL TOLERANCES (UNLESS SPECIFIED)	DIMENSION STYLE	SCALE	DESIGN UNITS	THIRD ANGLE PROJECTION
	▼=0 □=0	mm INCH 4 PLACES ± --- ± --- 3 PLACES ± --- ± .010 2 PLACES ± 0.25 ± .014 1 PLACE ± 0.35 ± --- ANGULAR ± 2 °	MM/IN	1:1	METRIC	
	DESCRIPTION	DRAWN BY	DATE	TITLE		
		KNOLLER	04/08/27	HIGH PROFILE TOP ENTRY JACK		
	CHECKED BY	DATE	MATERIAL NO.			
	FCARABET	04/08/30	SD-95522-001			
	APPROVED BY	DATE	SHEET NO.			
	KNOLLER	04/08/30	2 OF 3			
	DRAFT WHERE APPLICABLE MUST REMAIN WITHIN DIMENSIONS		THIS DRAWING CONTAINS INFORMATION THAT IS PROPRIETARY TO MOLEX INCORPORATED AND SHOULD NOT BE USED WITHOUT WRITTEN PERMISSION			