

DESCRIPTION:

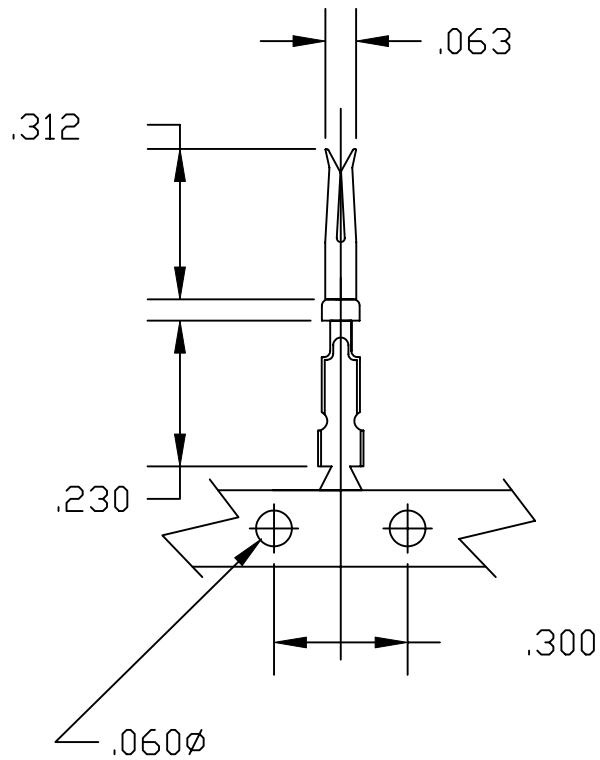

MATERIAL: BRASS  
RoHS COMPLIANT

WIRE SIZE: 24-28 AWG

NOTE #1: CONTACTS SUPPLIED ON 10,000 PC REEL  
NOTE #2: RECOMMENDED MAX. INSULATION DIAMETER FOR 24-28 AWG IS .035".

WIRE SIZE

PLATING:	24-28
GOLD FLASH ON MATING AREA NICKEL ON WIRE CRIMP	170-002-170L001
.000010" GOLD OVER .000050" NICKEL ENTIRE CONTACT	170-002-170L002
.000030" GOLD OVER .000100" NICKEL ENTIRE CONTACT	170-002-170L003

	THESE DRAWINGS AND SPECIFICATIONS ARE THE PROPERTY OF NorComp AND SHALL NOT BE REPRODUCED, COPIED OR USED AS THE BASIS FOR THE MANUFACTURE OF SALE OF APPARATUS WITHOUT WRITTEN PERMISSION.	DRAWN: PAM JENKINS	DATE: 5-28-02
		CHECKED:	DATE:
<h1>NorComp</h1>	SCALE:	SHEET 1 OF 1	REV 1
	DWG NO.	170-002-170L00X	