

DESCRIPTION: HIGH DENSITY FEMALE PIN & LOAD

POS.	A	B	C	D	E	F	G
15	1.213	0.984	0.644	0.756	0.311	0.606	0.496
26	1.543	1.312	0.966	1.091	0.311	0.954	0.496
44	2.087	1.852	1.512	1.618	0.311	1.498	0.496
62	2.732	2.500	2.156	2.256	0.311	2.147	0.496
78	2.083	2.406	2.057	2.169	0.429	2.043	0.606

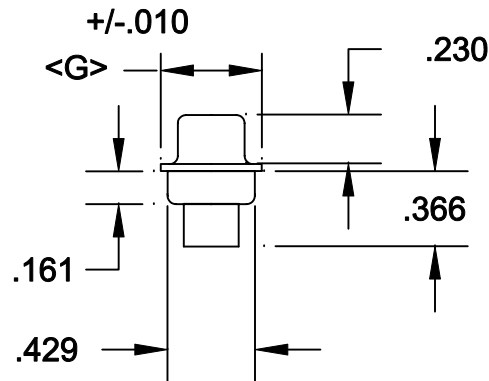
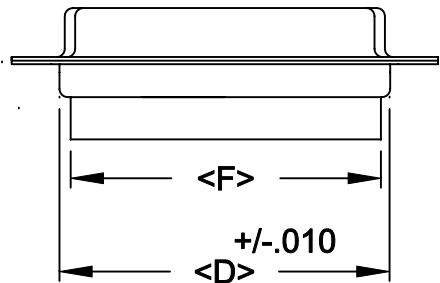
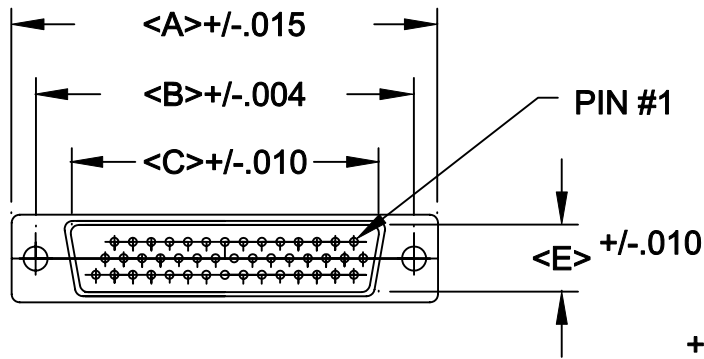

180-XXX-272-XX0

SERIES _____
 POSITIONS _____
 015
 026
 044
 062
 078
 GENDER _____
 1 = MALE
 2 = FEMALE
 TERMINATION _____
 7 = CRIMP/POKE
 SHELL PLATING _____
 2 = TIN
 HARDWARE OPTIONS _____
 00 = NO HARDWARE
 01 = .065 4-40 CLINCH NUT BOARD SIDE
 02 = .250 4-40 CLINCH NUT BOARD SIDE
 03 = .250 4-40 CLINCH NUT MATING SIDE
 91 = .225 4-40 SPACER/BOARD LOCK
 PLATING OPTIONS _____
 0 = NO CONTACTS

SPECIFICATIONS:

MATERIALS:

SHELL: STEEL, TIN PLATED
 INSULATOR: UL 94V-0 RATED BLACK PBT
 +30% FIBER-GLASS OR NYLON-66

ELECTRICALS:

CURRENT RATING: 2 AMPS
 CONTACT RESISTANCE: 15 mOHMS MAX
 INSULATOR RESISTANCE: 1000 MOHMS MIN
 VOLTAGE: 500V AC FOR 1 MINUTE
 TEMPERATURE: -50°C TO +100°C



THESE DRAWINGS AND SPECIFICATIONS ARE THE PROPERTY OF NorComp AND SHALL NOT BE REPRODUCED, COPIED OR USED AS THE BASIS FOR THE MANUFACTURE OR SALE OF APPARATUS WITHOUT WRITTEN PERMISSION.

DRAWN: PAM JENKINS		DATE: 8-12-98	
CHECKED:		DATE:	
SCALE:	SHEET	OF	REV 3
DWG NO. 180-XXX-272-XX0			

NorComp

DESCRIPTION: CLINCH NUT HARDWARE

ALL CLINCH-NUTS ARE 4-40 INTERNAL THREADS

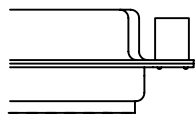

03X..... .250" (MATING SIDE) - CN8

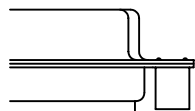

02X250" (BOARD SIDE) - CN2

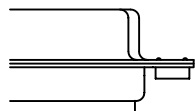

01X098" (BOARD SIDE) - CN1

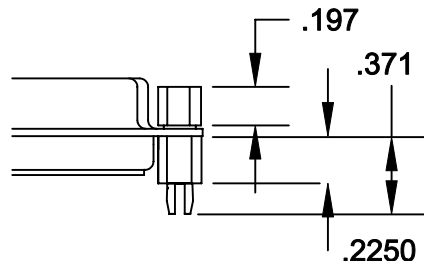

91X225" (BOARD SIDE) - .197 MATING SIDE - CN10/SFS0440

NOTE: 4-40 FEMALE SCREW LOCK IS REMOVABLE

	THESE DRAWINGS AND SPECIFICATIONS ARE THE PROPERTY OF NorComp AND SHALL NOT BE REPRODUCED, COPIED OR USED AS THE BASIS FOR THE MANUFACTURE OF SALE OF APPARATUS WITHOUT WRITTEN PERMISSION.		DRAWN: WAYNE ROBBINS	DATE: 8-23-98
	NorComp		CHECKED: PAM JENKINS	DATE: 8-24-98
SCALE:			SHEET 1 OF 1	REV 1
DWG NO.			CLINCH-NUT OPTIONS	