

THIS DRAWING IS UNPUBLISHED. RELEASED FOR PUBLICATION
 © COPYRIGHT BY TYCO ELECTRONICS CORPORATION. ALL RIGHTS RESERVED.

LOC	DIST	REVISIONS					
DF	DO	P	LTR	DESCRIPTION	DATE	DWN	APVD
		S		REV PER ECO 09-021968	29DEC09	PY	RL

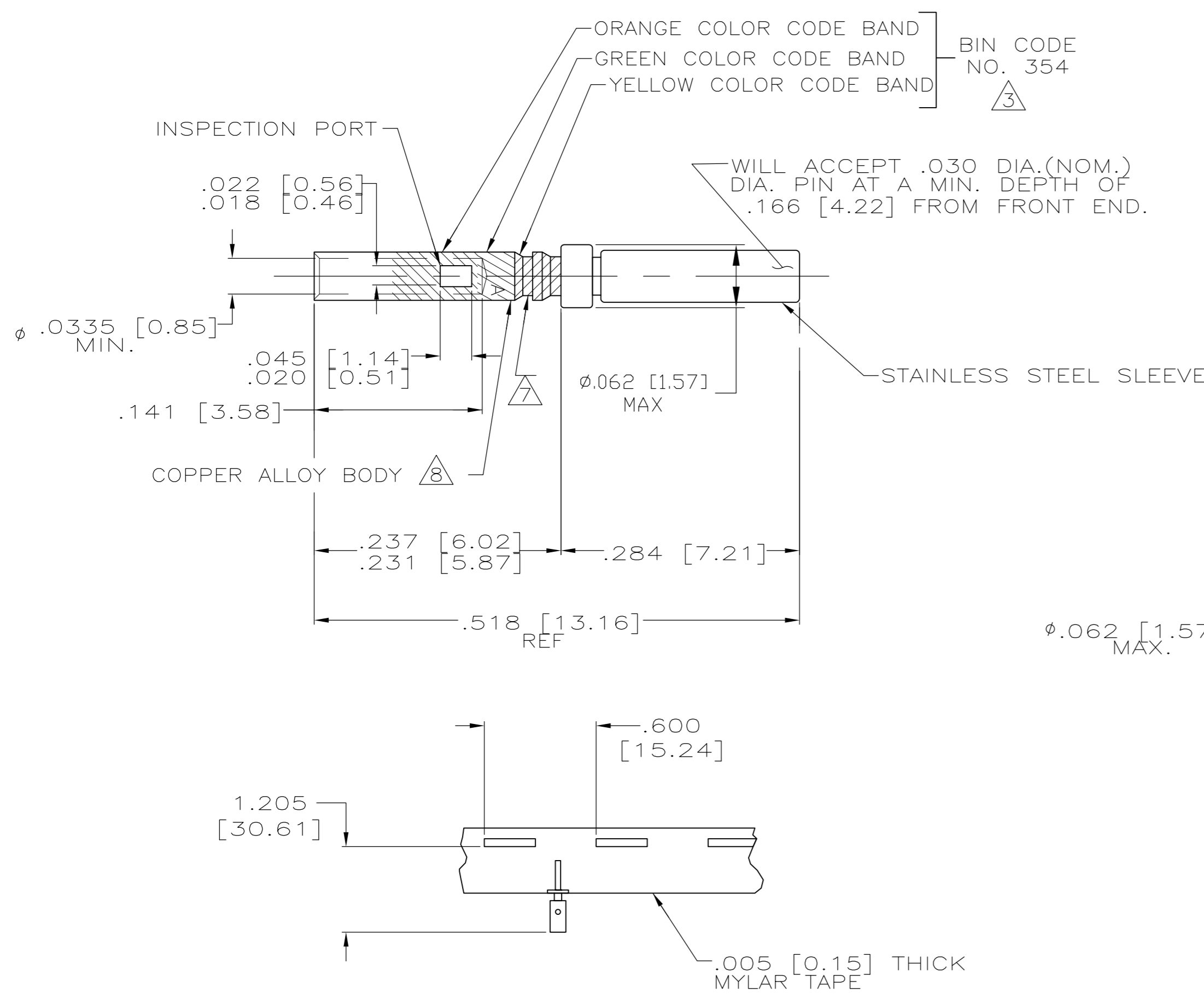

1. WIRE BARREL WILL ACCEPT #22-28 AWG WIRE.
2. CRIMPING TOOL- USE MS3198-1 WITH APPLICABLE POSITIONER.
3. CONTACT CONFORMS TO MIL-C-39029/57, SIZE 22.
4. NET WEIGHT- .102 GRAMS.
5. INSERTION, EXTRACTION TOOL- AMP P/N 91067-1.
6. THIS CONTACT IDENTIFIED AS MS27491-22 SUPERSEDES M24308/12-1.
7. IDENTIFICATION GROOVE IS OPTIONAL.
8. PLATING: GOLD PER MIL-G-45204 OVER NICKEL.
9. ALTERNATE LOCATION OF STAMPED MANUFACTURER'S MARK SHELL BE LOCATED ON THE CONTACT HOOD

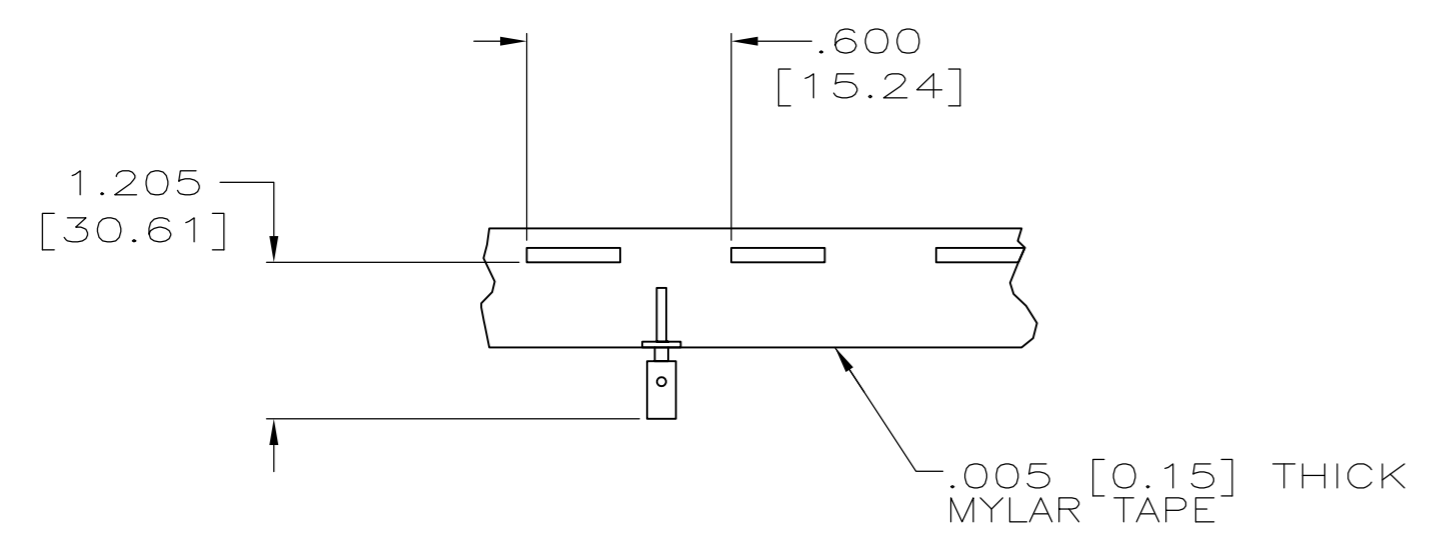
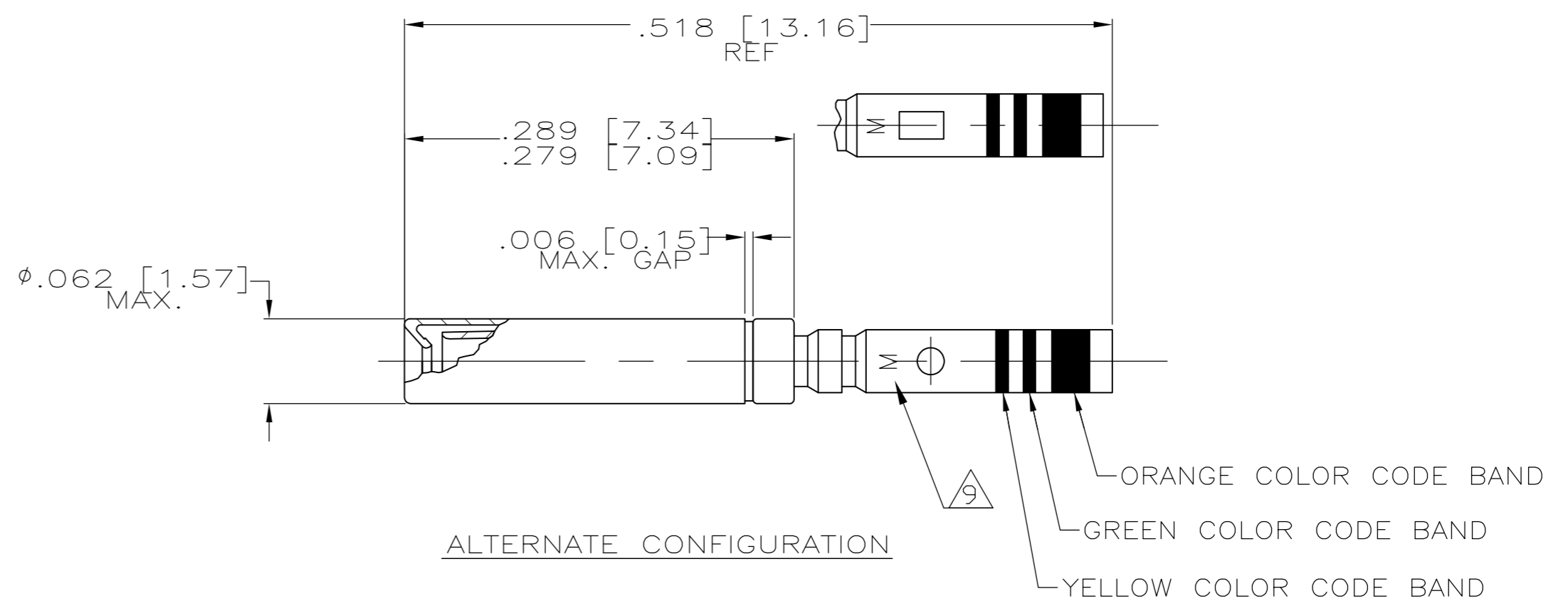

WHEN ORDERING CONTACT ON TAPE, ORDER BY THE TAPE NUMBER PLUS THE PACKAGEING CODE AS FOLLOWS:

2. FOR USE WITH AMP TAPETRONIC, PNEUMATIC TOOL-
A. 1000 PARTS TO A BOX ADD PACKAGING CODE: 1MBOX
3. FOR USE WITH 4/8 INDENT STRIPPER CRIMPER-
A. 1000 PARTS TO A REEL ADD PACKAGING CODE: 1MREEL
B. 5000 PARTS TO A REEL ADD PACKAGING CODE: 5MREEL

DESCRIPTION	PLATING	PART NO.
CONTACTS ON TAPE; COLOR CODED	8	204351-6
AS SHOWN; COLOR CODED	8	204351-5
AS SHOWN; NO COLOR CODE	8	204351-4
CONTACTS ON TAPE; COLOR CODED	8	204351-2
AS SHOWN; COLOR CODED	8	204351-1

THIS DRAWING IS A CONTROLLED DOCUMENT.		DWN R. RINEHART 10-5-90	Tyco Electronics Corporation Harrisburg, PA 17105-3608	
DIMENSIONS: INCHES [mm]		CHK R. GILLIMAN 10-10-90	NAME CONTACT ASS'Y, SOCKET SIZE 22D, AMPLIMITE	
TOLERANCES UNLESS OTHERWISE SPECIFIED:		APVD R. GILLIMAN 10-10-90	PRODUCT SPEC	
0 PLC ± -		APPLICATION SPEC		
1 PLC ± -		-		
2 PLC ± -		-		
3 PLC ± .005 [0.13]		-		
4 PLC ± -		-		
ANGLES ± -		-		
FINISH		-		
MATERIAL		WEIGHT .102 GRAMS		
-		CUSTOMER DRAWING		
-		SCALE 10:1		SHEET 1 of 1
-		REV S		RESTRICTED TO -