

THIS DRAWING IS UNPUBLISHED. RELEASED FOR PUBLICATION
 © COPYRIGHT BY TYCO ELECTRONICS CORPORATION. ALL RIGHTS RESERVED.

LOC	DIST	REVISIONS					
DF	DO	P	LTR	DESCRIPTION	DATE	DWN	APVD
		J		REV PER ECO 08-011681	22MAY08	PY	BW

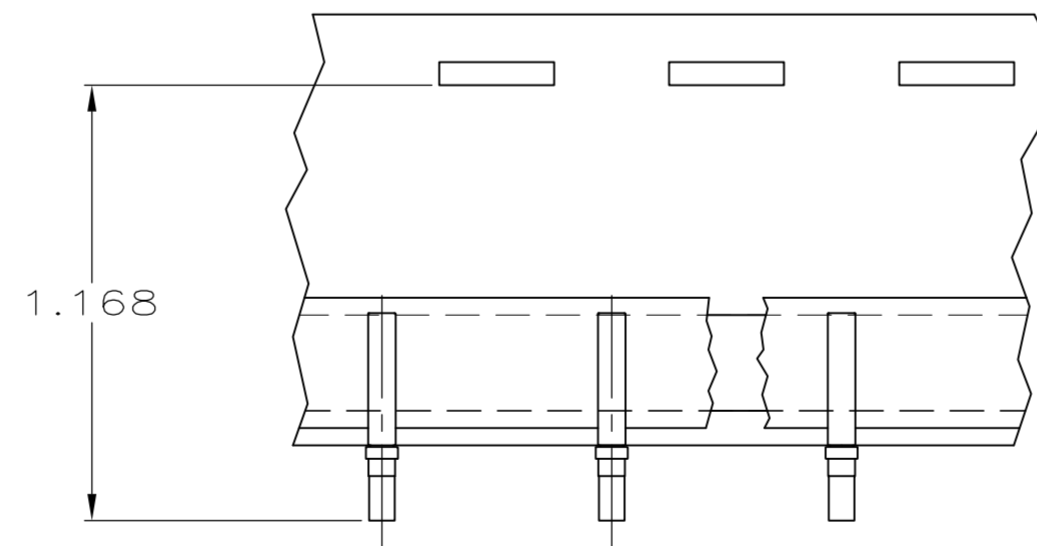
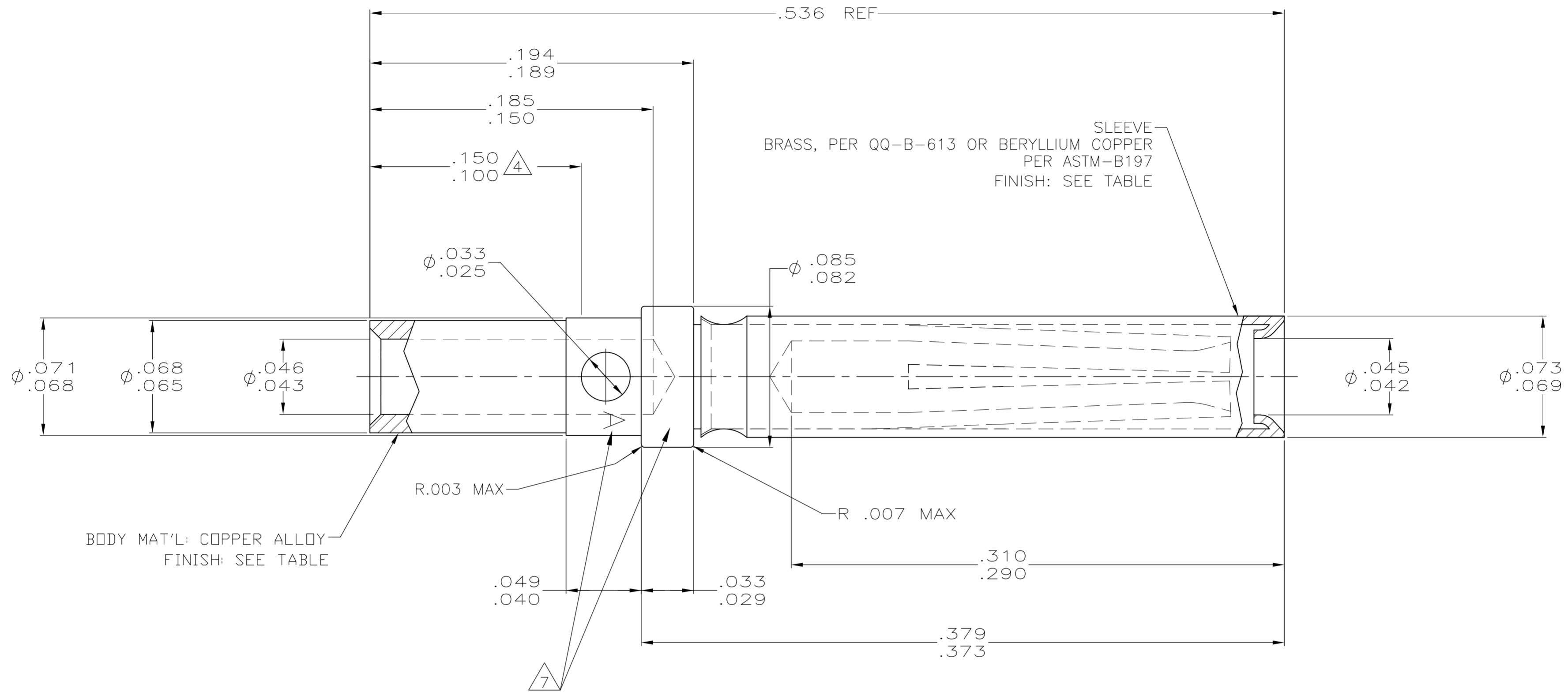

TAPE MOUNTED
 PART NO 206793-2 ONLY
 SCALE 2:1

- CONTACTS MUST MEET ALL REQUIREMENTS OF GSFC-S-311-P-4/08 AND AS39029.
- ALL DIAMETERS ARE CONCENTRIC WITH EACH OTHER WITHIN $.004$ T.I.R.
- ALL SURFACES HAVE $\sqrt{63}$ OR BETTER FINISH. POINT OF PLATING THICKNESS MEASUREMENT.
- SLEEVE MAY BE CRIMPED OR DIMPLED TO BODY.
- ~~MINIMUM SEPERATION FORCE OF 7 OZ USING A .039 PIN AND 4 OZ MAX ENGAGEMENT FORCE USING A .041 PIN.~~
- OPTIONAL LOCATION FOR STAMPED LETTER "A"
- PLATING: GOLD PER ASTM-B-488 (TYPEII) OVER COPPER PER MIL-C-14550, CLASS 4.
- PLATING: GOLD PER ASTM-B-488 (TYPEII) OVER NICKEL PER QQ-N-290.

	$\triangle 9$	AS SHOWN	206793-4
OBSOLETE	$\triangle 8$	SAME AS -1 EXCEPT $\triangle 6$	206793-3
	$\triangle 8$	SAME AS -1 EXCEPT TAPE MOUNTED 5,000 CONTACTS PER REEL	206793-2
	$\triangle 8$	AS SHOWN	206793-1
	FINISH	DESCRIPTION	PART NO

DIMENSIONS:		TOLERANCES UNLESS OTHERWISE SPECIFIED:		DWN		Tyco Electronics Corporation	
INCHES		0 PLC $\pm -$		C.C.THOMAS 11-20-02		Tyco Electronics Corporation	
ϕ		1 PLC $\pm -$		CHK D.MILLER 11-20-02		Harrisburg, PA 17105-3608	
		2 PLC $\pm -$		APVD D.MILLER 11-20-02		NAME	
		3 PLC $\pm -$		PRODUCT SPEC		SOCKET CONTACT ASSY, SIZE 20, AMPLIMITE	
		4 PLC $\pm -$		APPLICATION SPEC		SIZE	
		ANGLES $\pm -$		WEIGHT		CAGE CODE	
MATERIAL		FINISH		-		DRAWING NO	
SEE CALLOUT		-		CUSTOMER DRAWING		A2 00779 C=206793	
				SCALE		SHEET	
				20:1		1 of 1	
				REV		J	