

THIS DRAWING IS UNPUBLISHED. RELEASED FOR PUBLICATION
 (C) COPYRIGHT 19 BY AMP INCORPORATED, ALL RIGHTS RESERVED.

LOC	DIST	REVISIONS					
DF	DO	P	LTR	DESCRIPTION	DATE	DWN	APVD
		H		REV PER 063D-0520-00	7-03	CT	DM

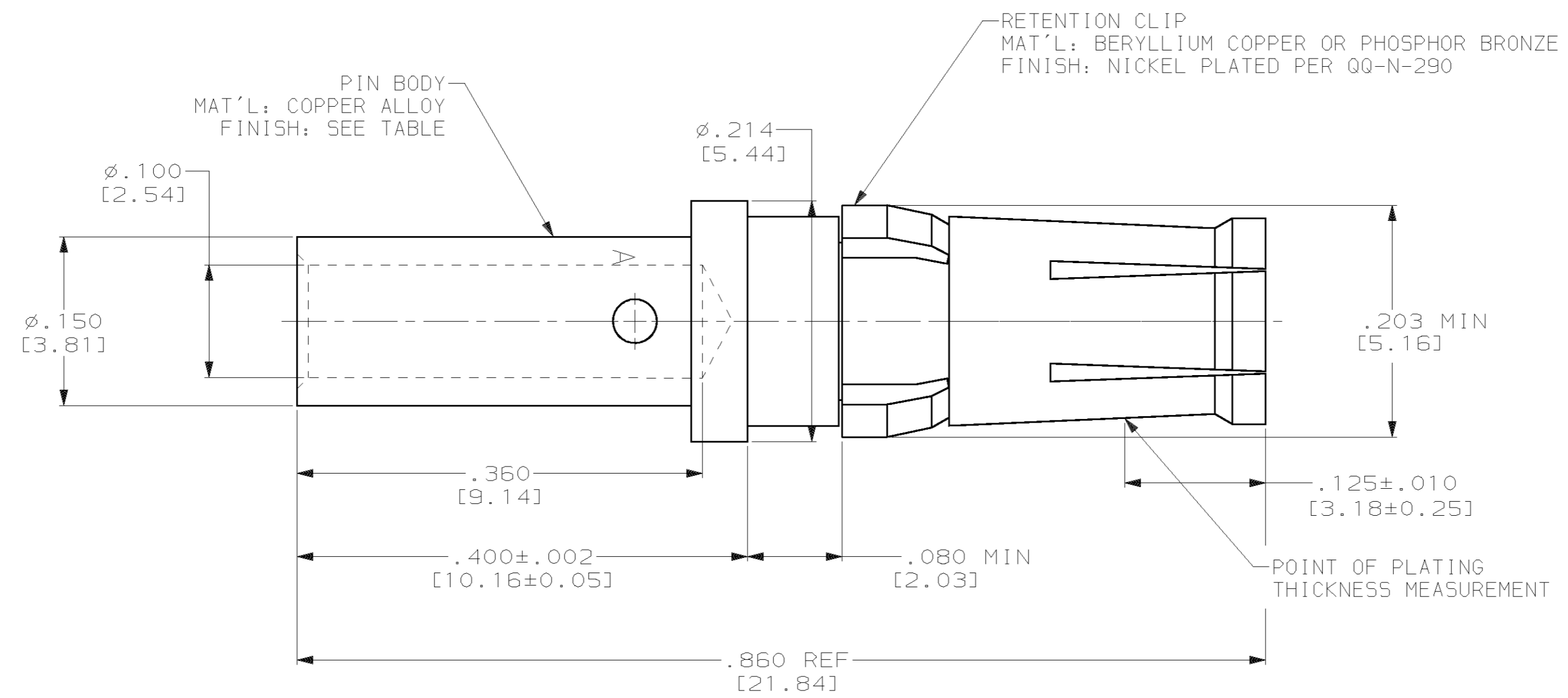

- THIS PART CONFORMS TO REQUIREMENTS FOR DANIELS CRIMP TOOL NO. M300-BT, WITH DANIELS POSITIONER PART NO. 5P689, STRIP LENGTH .375, SETTING #1.
- MATES WITH 212007-1 IN AMPLIMITE CONNECTOR ASSEMBLIES ONLY.
- FINISH: PLATED GOLD .000050 [0.00127] MIN THK PER MIL-G-45204 OVER NICKEL .000050 [0.00127] MIN THK PER QQ-N-290.
- FINISH: PLATED GOLD .000030 [0.00076] MIN THK PER MIL-G-45204 OVER NICKEL .000050 [0.00127] MIN THK PER QQ-N-290.
- WIRE BARREL WILL ACCEPT #12-#14 AWG WIRE.

PRELIMINARY NOT RELEASED FOR PRODUCTION	4	212008-2
	3	212008-1
	FINISH	PART NUMBER

THIS DRAWING IS A CONTROLLED DOCUMENT.		DWN	C.C. THOMAS	11/10/00	AMP Incorporated Harrisburg, PA 17105-3608	
DIMENSIONS: INCHES [mm]		CHK	D. MILLER	11/10/00		
TOLERANCES UNLESS OTHERWISE SPECIFIED:		APVD	D. MILLER	11/10/00		
0 PLC ±- 1 PLC ±- 2 PLC ±- 3 PLC ±.005 [0.13] 4 PLC ±- ANGLES ±-		NAME	ASSEMBLY, SOCKET CONTACT POWER VIII, #12 & #14 AWG			
MATERIAL	SEE CALLOUTS	FINISH	SEE TABLE	PRODUCT SPEC	108-10045	
		APPLICATION SPEC	114-10014		SIZE	A2
		WEIGHT	-		CAGE CODE	00779
		CUSTOMER DRAWING	SCALE 10:1		DRAWING NO	212008
			SHEET 1 OF 1		RESTRICTED TO	-
			REV H			