

THIS DRAWING IS UNPUBLISHED. RELEASED FOR PUBLICATION  
 © COPYRIGHT BY TYCO ELECTRONICS CORPORATION. ALL RIGHTS RESERVED.

LOC		DIST		REVISIONS					
AD	00	P	LTR	DESCRIPTION			DATE	DWN	APVD
		P1		REVISED PER ECO-09-021826			09JAN10	KK	AEG

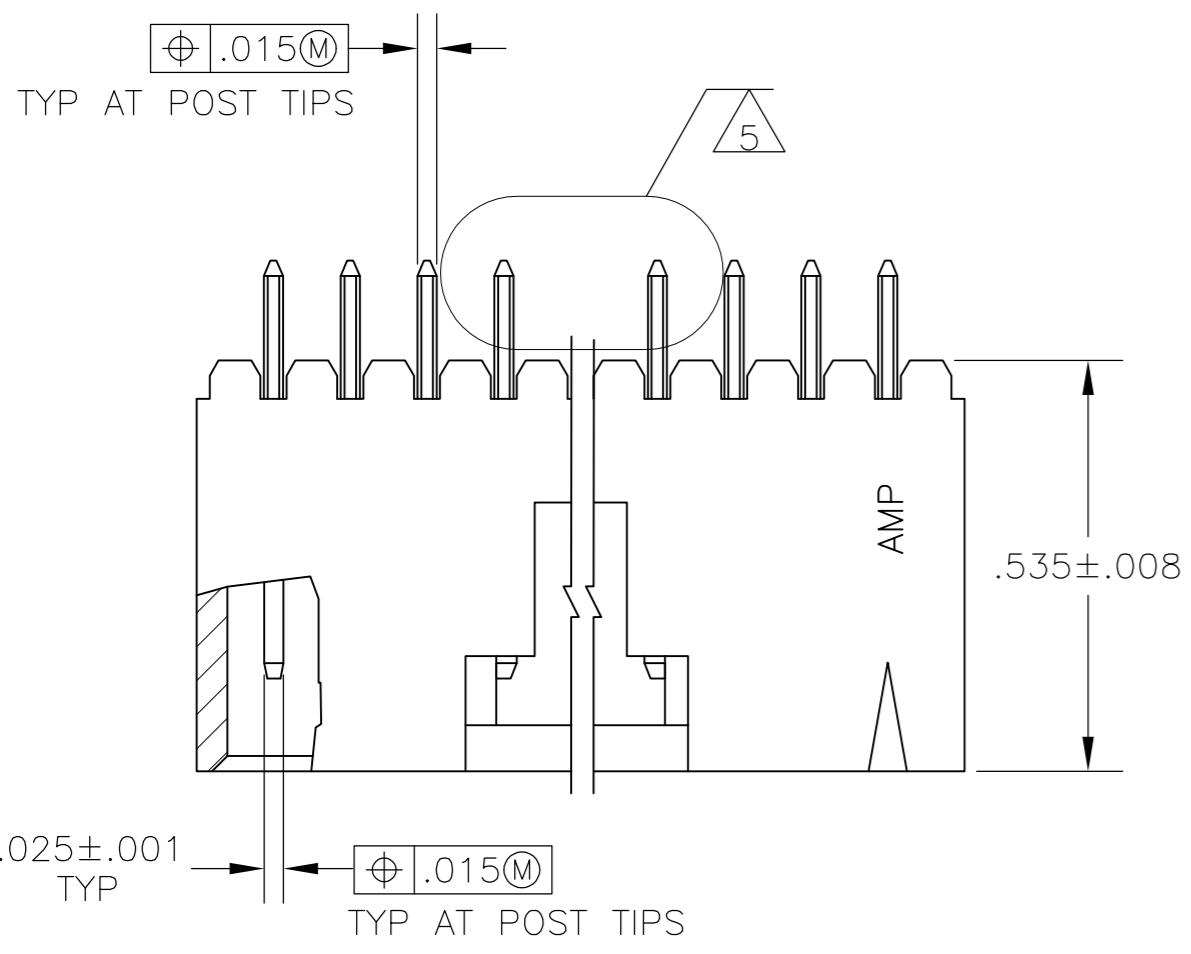

- 1 .000030 GOLD IN THE CONTACT AREA, .000100-.000200 MATTE TIN-LEAD ON THE SOLDER TAIL, ALL OVER .000050 NICKEL
- 2 POINT OF MEASUREMENT FOR PLATING THICKNESS
- 3 THESE DIMENSIONS APPLY WHERE THE POST INTERSECTS THE HOUSING
- 4 ON ASSEMBLIES WITH FOUR OR MORE POSITIONS, TWO POLARIZATION SLOTS. ON ASSEMBLIES WITH TWO OR THREE POSITIONS, ONE POLARIZATION SLOT.
- 5 SELECT POST TAILS FORMED TO PROVIDE CONNECTOR HOLD DOWN UNTIL SOLDERED. CONFIGURATION ACCEPTS .027-.080 THICK PRINTED CIRCUIT BOARD. (SEE DETAIL Z)
- 6 .000030 GOLD IN THE CONTACT AREA, .000100-.000200 MATTE TIN ON THE SOLDER TAIL, ALL OVER .000050 NICKEL
- 7 HIGH TEMPERATURE CONFIGURATION
- 8 STANDOFFS NOT PRESENT ON UNDERSIDE OF ASSEMBLY
- 9 OBSOLETE PARTS: OBSOLETE CIS STREAMLINING PER D.RENAUD/D.SINISI

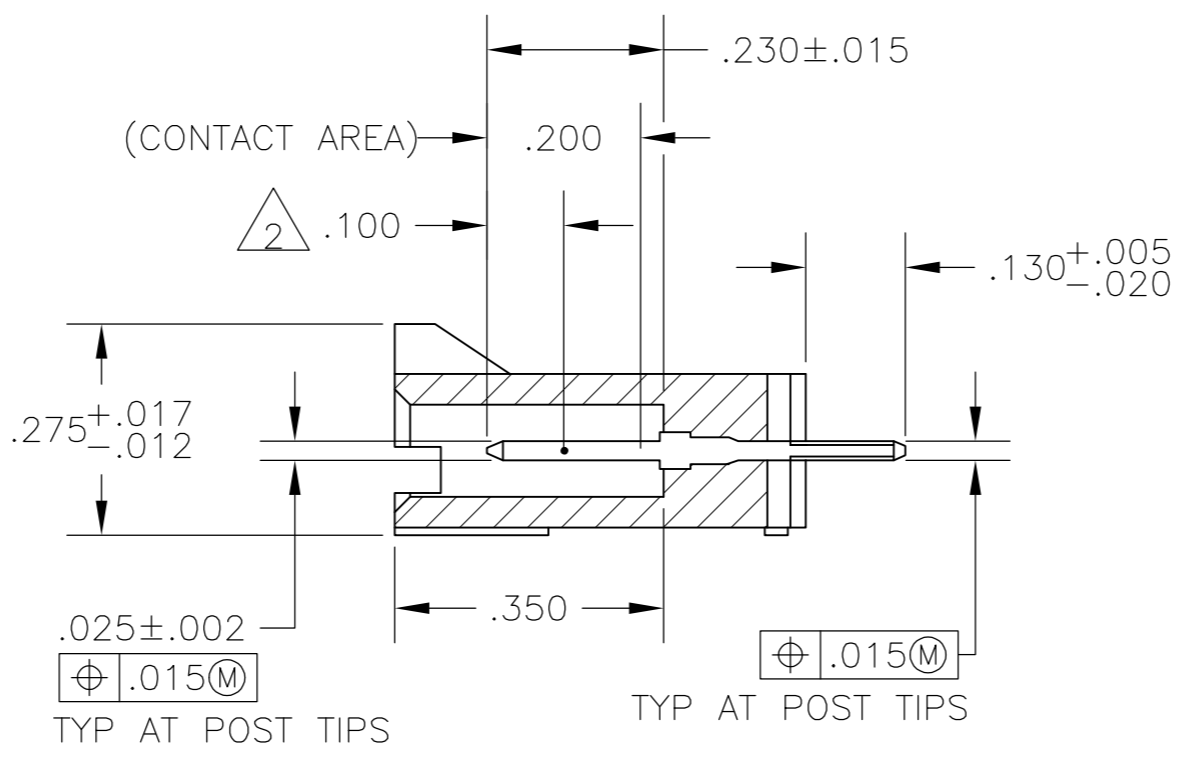
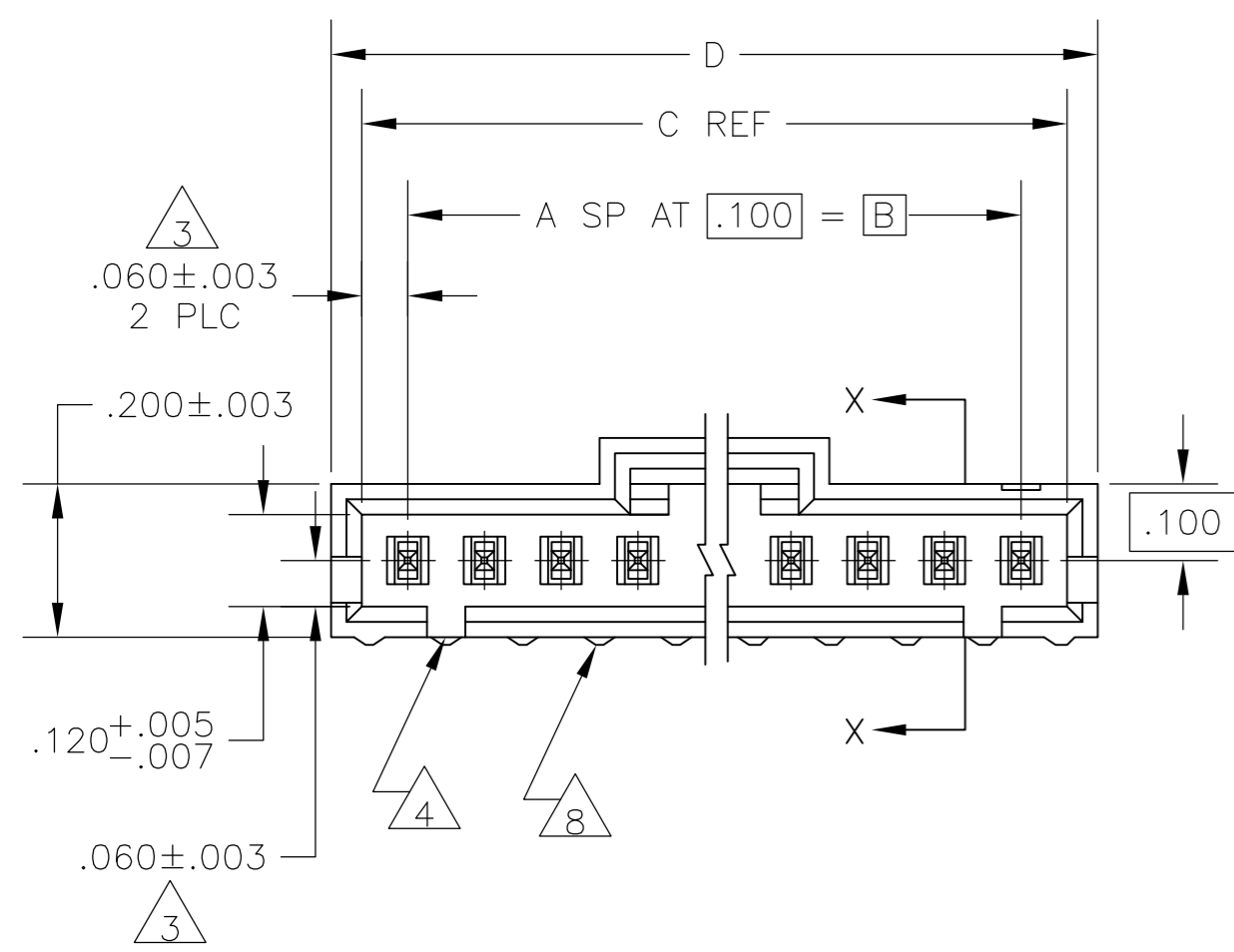

SECTION X-X

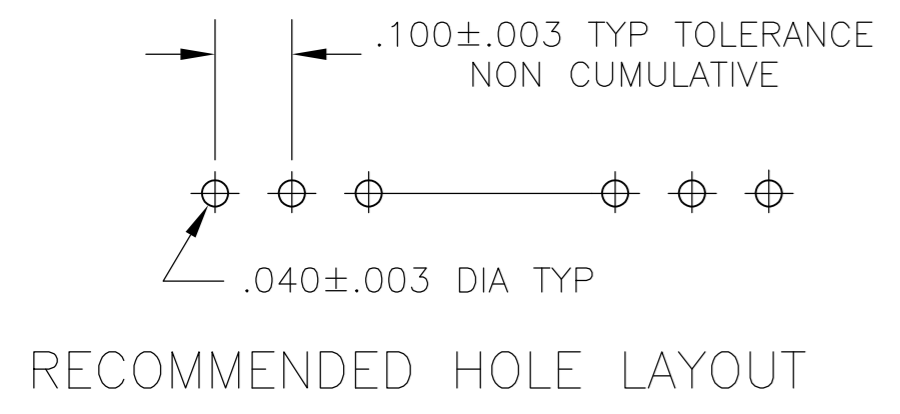
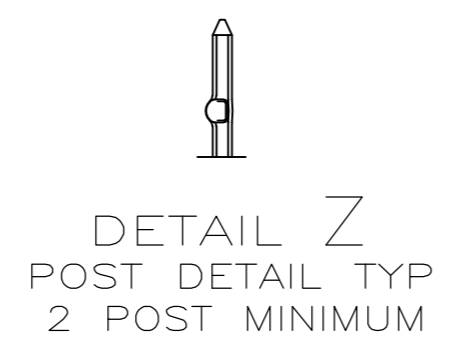

REMARKS	PLATING	D	C	B	A	NO OF POSN	ASSEMBLY PART NUMBER	
9	7 8	6	2.600	2.520	2.400	24	25	7-103908-4
9	7 8	6	2.500	2.420	2.300	23	24	7-103908-3
9	7 8	6	2.400	2.320	2.200	22	23	7-103908-2
9	7 8	6	2.300	2.220	2.100	21	22	7-103908-1
9	7 8	6	2.200	2.120	2.000	20	21	7-103908-0
9	7 8	6	2.100	2.020	1.900	19	20	6-103908-9
9	7 8	6	2.000	1.920	1.800	18	19	6-103908-8
9	7 8	6	1.900	1.820	1.700	17	18	6-103908-7
9	7 8	6	1.800	1.720	1.600	16	17	6-103908-6
9	7 8	6	1.700	1.620	1.500	15	16	6-103908-5
9	7 8	6	1.600	1.520	1.400	14	15	6-103908-4
9	7 8	6	1.500	1.420	1.300	13	14	6-103908-3
9	7 8	6	1.400	1.320	1.200	12	13	6-103908-2
9	7 8	6	1.300	1.220	1.100	11	12	6-103908-1
9	7 8	6	1.200	1.120	1.000	10	11	6-103908-0
9	7 8	6	1.100	1.020	.900	9	10	5-103908-9
9	7 8	6	1.000	.920	.800	8	9	5-103908-8
9	7 8	6	.900	.820	.700	7	8	5-103908-7
9	7 8	6	.800	.720	.600	6	7	5-103908-6
9	7 8	6	.700	.620	.500	5	6	5-103908-5
9	7 8	6	.600	.520	.400	4	5	5-103908-4
9	7 8	6	.500	.420	.300	3	4	5-103908-3
9	7 8	6	.400	.320	.200	2	3	5-103908-2
9	7 8	6	.300	.220	.100	1	2	5-103908-1
9	1	1	2.600	2.520	2.400	24	25	2-103908-4
9	1	1	2.500	2.420	2.300	23	24	2-103908-3
9	1	1	2.400	2.320	2.200	22	23	2-103908-2
9	1	1	2.300	2.220	2.100	21	22	2-103908-1
9	1	1	2.200	2.120	2.000	20	21	2-103908-0
9	1	1	2.100	2.020	1.900	19	20	1-103908-9
9	1	1	2.000	1.920	1.800	18	19	1-103908-8
9	1	1	1.900	1.820	1.700	17	18	1-103908-7
9	1	1	1.800	1.720	1.600	16	17	1-103908-6
9	1	1	1.700	1.620	1.500	15	16	1-103908-5
9	1	1	1.600	1.520	1.400	14	15	1-103908-4
9	1	1	1.500	1.420	1.300	13	14	1-103908-3
9	1	1	1.400	1.320	1.200	12	13	1-103908-2
9	1	1	1.300	1.220	1.100	11	12	1-103908-1
9	1	1	1.200	1.120	1.000	10	11	1-103908-0
9	1	1	1.100	1.020	.900	9	10	103908-9
9	1	1	1.000	.920	.800	8	9	103908-8
9	1	1	.900	.820	.700	7	8	103908-7
9	1	1	.800	.720	.600	6	7	103908-6
9	1	1	.700	.620	.500	5	6	103908-5
9	1	1	.600	.520	.400	4	5	103908-4
9	1	1	.500	.420	.300	3	4	103908-3
9	1	1	.400	.320	.200	2	3	103908-2
9	1	1	.300	.220	.100	1	2	103908-1

THIS DRAWING IS A CONTROLLED DOCUMENT.

DWN H MOLL 7-28-86  
 CHK PC deJONG 7-28-86  
 APVD PC deJONG 7-28-86

TOLERANCES UNLESS OTHERWISE SPECIFIED:  
 0 PLC ± -  
 1 PLC ± -  
 2 PLC ± -  
 3 PLC ± .005  
 4 PLC ± -  
 ANGLES ± -  
 FINISH SEE TABLE

MATERIAL HOUSING: FLAME RETARDANT THERMOPLASTIC COLOR-BLACK CONTACTS-BRASS

NAME: Tyco Electronics Corporation, Harrisburg, Pa 17105-3608  
 Tyco Electronics  
 HEADER ASSY, AMPMODU MTE, VERTICAL, SINGLE ROW, .100 C, .025 SQ POSTS WITH LATCH & RETENTIVE POSTS

SIZE: A2 CAGE CODE: 00779 DRAWING NO: 103908  
 WEIGHT: -  
 CUSTOMER DRAWING

RESTRICTED TO: -  
 SCALE: 4:1 SHEET: 1 OF 1 REV: P1