

THIS DRAWING IS UNPUBLISHED. RELEASED FOR PUBLICATION
 © COPYRIGHT BY TYCO ELECTRONICS CORPORATION. ALL RIGHTS RESERVED.

LOC		DIST		REVISIONS			
P	LTR	DESCRIPTION		DATE	DWN	APVD	
U1		REVISED PER ECO-10-000443		13JAN10	KK	HMR	

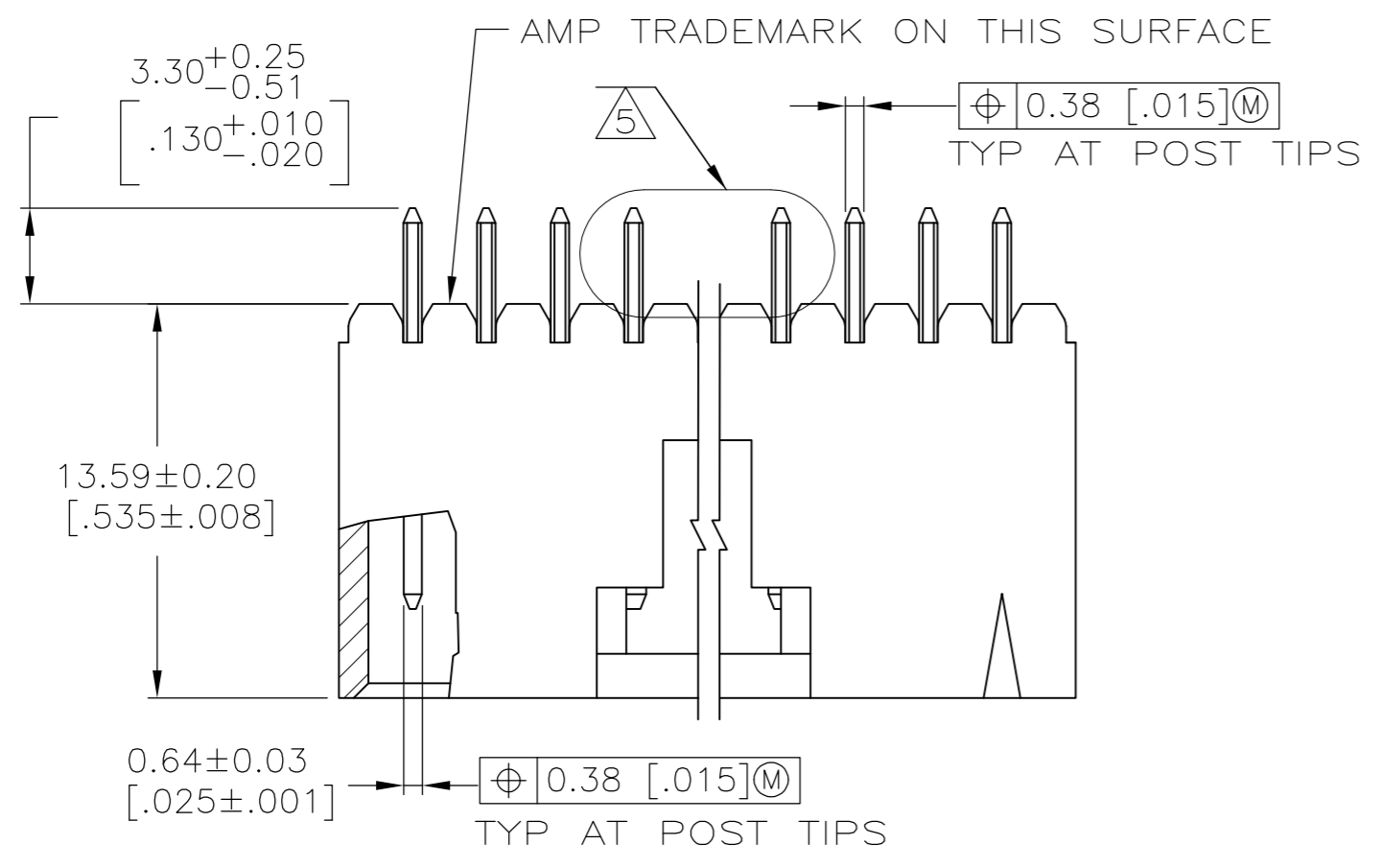

- 1 0.000381 [.000015] GOLD IN THE CONTACT AREA, 0.00254-0.00508 [.000100-.000200] MATTE TIN-LEAD ON THE SOLDER TAIL, ALL OVER ALL OVER 0.00127 [.000050] NICKEL.
- 2 POINT OF MEASUREMENT FOR PLATING THICKNESS
- 3 THE NOTED DIMENSIONS APPLY FROM THE BASIC DIMENSION LINE (NOT THE POST CENTERLINE) TO THE SURFACE INDICATED
- 4 ONE POLARIZATION SLOT FOR 2 AND 3 POSITION ASSEMBLIES ONLY.
- 5 SELECT POST TAILS FORMED TO PROVIDE CONNECTOR HOLD DOWN UNTIL SOLDERED, CONFIGURATION ACCEPTS 0.69-2.03 [.027-.080] THICK PRINTED CIRCUIT BOARD (SEE DETAIL Z).
- 6 DIMENSIONS NOTED ARE FOR SOLDER STENCIL LAYOUT FOR USE WITH 1.57±0.20 [.062±.008] THICK PRINTED CIRCUIT BOARDS.
- 7 PARTS ARE PACKAGED IN GANG OF TUBES

- 8 OBSOLETE PART NO., REFER TO DWG 104909 FOR POS 13 THRU 25.
- 9 HOUSING: HIGH TEMPERATURE THERMOPLASTIC, COLOR-BLACK. POSTS: BRASS.
- 10 0.000381 [.000015] GOLD IN THE CONTACT AREA, 0.00254-0.00508 [.000100-.000200] MATTE TIN ON THE SOLDER TAIL, ALL OVER ALL OVER 0.00127 [.000050] NICKEL.
- 11 SUPERSEDED

PART NO.	SUPERSEDED BY
1-104362-2	1-104909-2
1-104362-4	1-104909-4
1-104362-7	1-104909-7
2-104362-2	—
2-104362-3	—

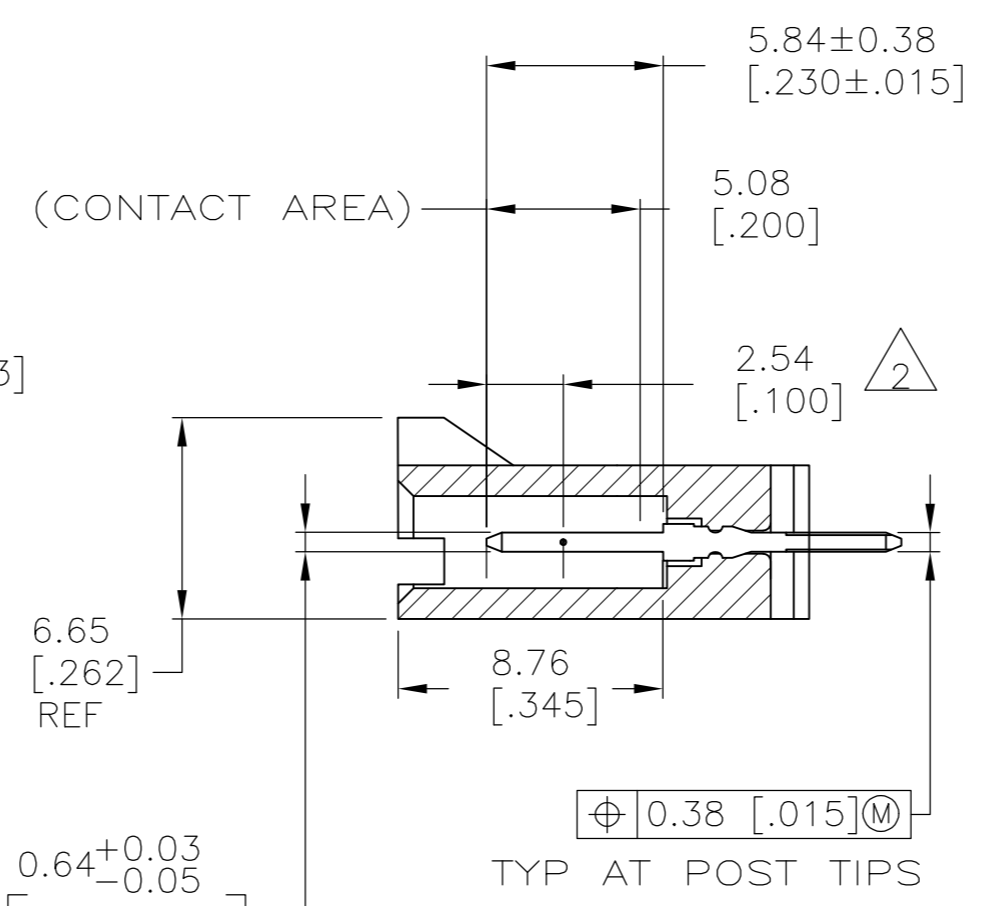
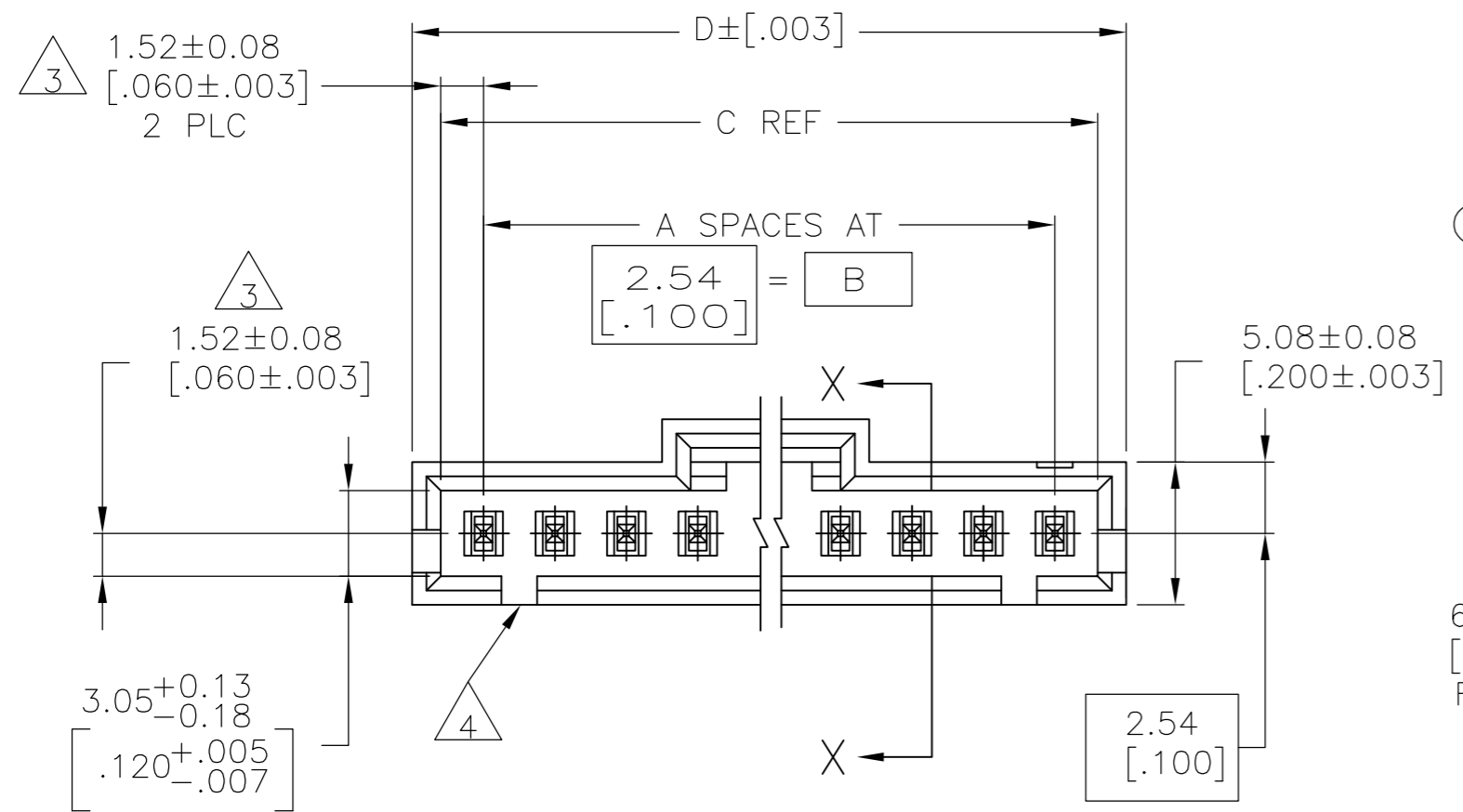

10	33.02 [1.300]	30.99 [1.220]	27.94 [1.100]	11	12	6-104362-1
10	30.48 [1.200]	28.45 [1.120]	25.4 [1.000]	10	11	6-104362-0
10	27.94 [1.100]	25.91 [1.020]	22.86 [.900]	9	10	5-104362-9
10	25.4 [1.000]	23.37 [.920]	20.32 [.800]	8	9	5-104362-8
10	22.86 [.900]	20.83 [.820]	17.78 [.700]	7	8	5-104362-7
10	20.32 [.800]	18.29 [.720]	15.24 [.600]	6	7	5-104362-6
10	17.78 [.700]	15.75 [.620]	12.7 [.500]	5	6	5-104362-5
10	15.24 [.600]	13.21 [.520]	10.16 [.400]	4	5	5-104362-4
10	12.7 [.500]	10.67 [.420]	7.62 [.300]	3	4	5-104362-3
10	10.16 [.400]	8.13 [.320]	5.08 [.200]	2	3	5-104362-2
10	7.62 [.300]	5.59 [.220]	2.54 [.100]	1	2	5-104362-1
	66.04 [2.600]	64.01 [2.520]	60.96 [2.400]	24	25	2-104362-4
	63.5 [2.500]	61.47 [2.420]	58.42 [2.300]	23	24	2-104362-3
	60.96 [2.400]	58.93 [2.320]	55.88 [2.200]	22	23	2-104362-2
	58.42 [2.300]	56.39 [2.220]	53.34 [2.100]	21	22	2-104362-1
	55.88 [2.200]	53.85 [2.120]	50.8 [2.000]	20	21	2-104362-0
	53.34 [2.100]	51.31 [2.020]	48.26 [1.900]	19	20	1-104362-9
	50.8 [2.000]	48.77 [1.920]	45.72 [1.800]	18	19	1-104362-8
	48.26 [1.900]	46.23 [1.820]	43.18 [1.700]	17	18	1-104362-7
	45.72 [1.800]	43.69 [1.720]	40.64 [1.600]	16	17	1-104362-6
	43.18 [1.700]	41.15 [1.620]	38.1 [1.500]	15	16	1-104362-5
	40.64 [1.600]	38.61 [1.520]	35.56 [1.400]	14	15	1-104362-4
	38.1 [1.500]	36.07 [1.420]	33.02 [1.300]	13	14	1-104362-3
	35.56 [1.400]	33.53 [1.320]	30.48 [1.200]	12	13	1-104362-2
1	33.02 [1.300]	30.99 [1.220]	27.94 [1.100]	11	12	1-104362-1
1	30.48 [1.200]	28.45 [1.120]	25.4 [1.000]	10	11	1-104362-0
1	27.94 [1.100]	25.91 [1.020]	22.86 [.900]	9	10	104362-9
1	25.4 [1.000]	23.37 [.920]	20.32 [.800]	8	9	104362-8
1	22.86 [.900]	20.83 [.820]	17.78 [.700]	7	8	104362-7
1	20.32 [.800]	18.29 [.720]	15.24 [.600]	6	7	104362-6
1	17.78 [.700]	15.75 [.620]	12.7 [.500]	5	6	104362-5
1	15.24 [.600]	13.21 [.520]	10.16 [.400]	4	5	104362-4
1	12.7 [.500]	10.67 [.420]	7.62 [.300]	3	4	104362-3
1	10.16 [.400]	8.13 [.320]	5.08 [.200]	2	3	104362-2
1	7.62 [.300]	5.59 [.220]	2.54 [.100]	1	2	104362-1

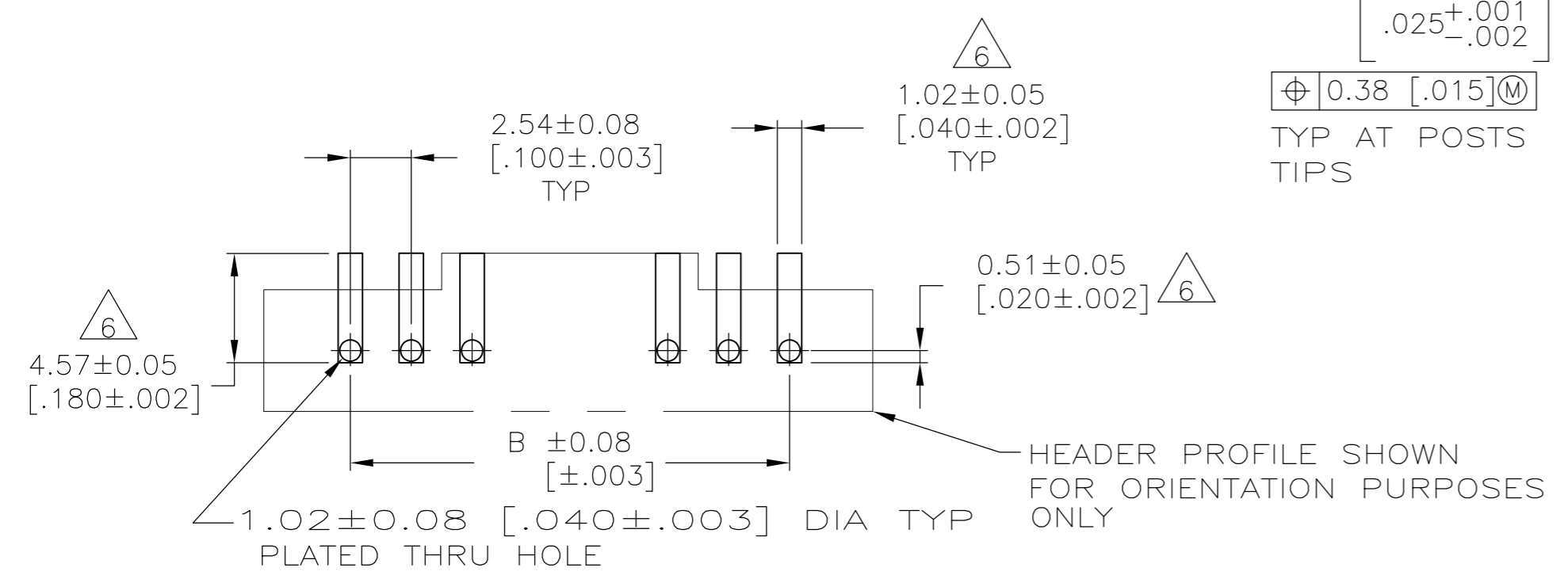

RECOMMENDED PC BOARD MOUNTING DIMENSIONS
 RECOMMENDED STENCIL THICKNESS = 0.25 [.010]

THIS DRAWING IS A CONTROLLED DOCUMENT. DWN G DOUTY 2-22-88
 CHK T C CLARK 2-22-88

Tyco Electronics Corporation
 Harrisburg, Pa 17105-3608

NAME: HEADER ASSY, AMPMODU MTE, VERTICAL SINGLE ROW, .100 C/L, .025 SQ POST POLARIZED, WITH LATCHING & HOLD DOWN

SIZE: A2 CAGE CODE: 00779 DRAWING NO: 104362 RESTRICTED TO: —

MATERIAL: SEE TABLE FINISH: — WEIGHT: — CUSTOMER DRAWING SCALE: 4:1 SHEET: 1 OF 1 REV: U1