

THIS DRAWING IS UNPUBLISHED. RELEASED FOR PUBLICATION
 © COPYRIGHT BY TYCO ELECTRONICS CORPORATION. ALL RIGHTS RESERVED.

LOC	DIST	REVISIONS					
		P	LTR	DESCRIPTION	DATE	DWN	APVD
AJ	16		N	REVISED PER ECO 07-010538	04MAY2007	DW	GM
			N1	REVISED PER ECO-09-020774	25AUG09	KK	AEG

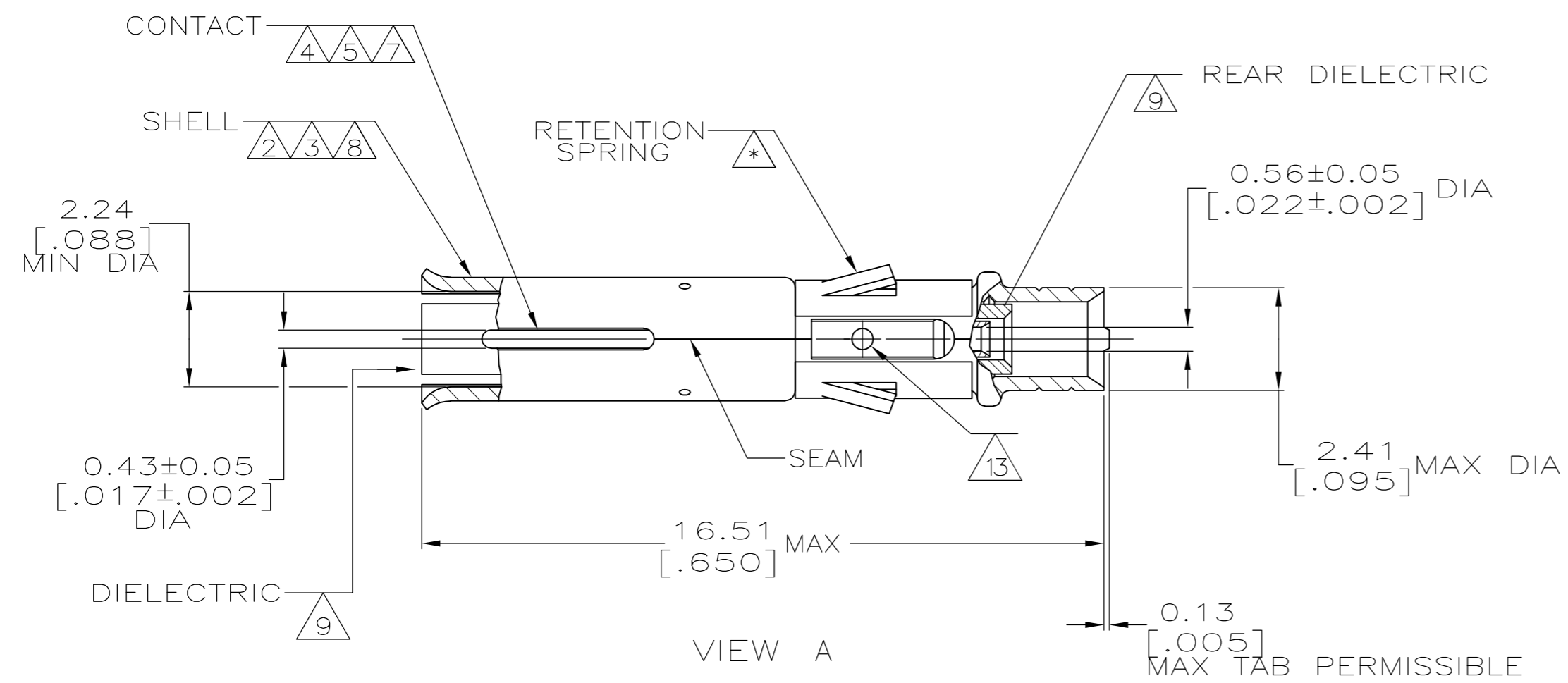

VIEW A

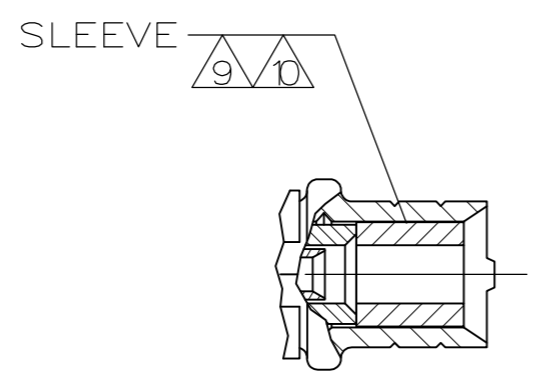

VIEW B

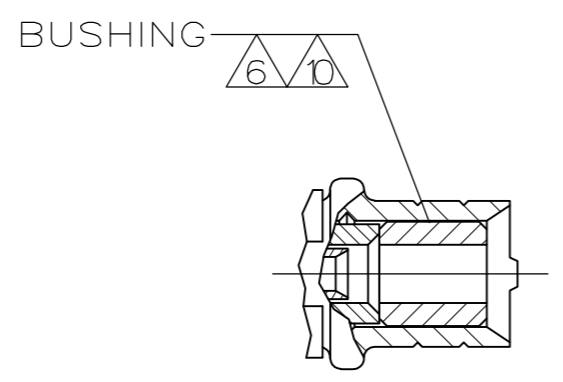

VIEW C

1. FOR CABLE SELECTION, FERRULE AND HANDTOOL PART NUMBERS, SEE I.S. 2024-2

- △2 GOLD PLATE PER MIL-G-45204,.000027 MINIMUM THICKNESS
- △3 GOLD PLATE PER MIL-G-45204,.000045 MINIMUM THICKNESS
- △4 GOLD PLATE PER MIL-G-45204,.000030 MINIMUM THICKNESS
- △5 GOLD PLATE PER MIL-G-45204,.000050 MINIMUM THICKNESS
- △6 TIN PLATE PER MIL-T-10272
- △7 BRASS PER QQ-B-626
- △8 BRASS PER MIL-C-50
- △9 POLYPROPYLENE,GENERAL PURPOSE
- △10 BRASS PER ASTM-B-135
- △11 STAINLESS STEEL,SPRING TEMPER PER QQ-S-766
- △12 PTFE PER MIL-P-19468
- △13 SIGHT HOLE VISIBLE THROUGH THE PORT SLOT ON RETENTION SPRING
- △14 OBSOLETE PARTS: OBSOLETE CIS STREAMLINING PER D.RENAUD/D.SINISI

△13	OBSOLETE	A	△2 △4	△7 △8 △9 △11	1-51565-5
△14	OBSOLETE	A	△2 △4	△7 △8 △9 △11	1-51565-4
	OBSOLETE	B	△3 △5	△7 △8 △9 △11 △12	1-51565-3
	OBSOLETE	C	△3 △5 △6	△7 △8 △9 △10 △11	51565-6
	OBSOLETE	B	△3 △5	△7 △8 △9 △11	51565-5
	OBSOLETE	A	△3 △5	△7 △8 △9 △11	51565-4
		C	△2 △4 △6	△7 △8 △9 △10 △11	51565-3
		B	△2 △4	△7 △8 △9 △11	51565-2
		A	△2 △4	△7 △8 △9 △11	51565-1
		VIEW	FINISH	MATERIAL	PART NUMBER

THIS DRAWING IS A CONTROLLED DOCUMENT.

DWN: B. WERNER 4-23-91
 CHK: D. DOYE 5-3-91
 APVD: -
 PRODUCT SPEC: -
 APPLICATION SPEC: -
 WEIGHT: -

Tyco Electronics Tyco Electronics Corporation
 Harrisburg, PA 17105-3608

NAME: -
 PRODUCT SPEC: -
 APPLICATION SPEC: -
 WEIGHT: -

SIZE: A2 CAGE CODE: 00779 DRAWING NO: C=51565 RESTRICTED TO: -
 SCALE: 8:1 SHEET: 1 of 1 REV: N1

CUSTOMER DRAWING