

© COPYRIGHT 1977 BY AMP INCORPORATED, HARRISBURG, PA.  
 ALL INTERNATIONAL RIGHTS RESERVED. AMP INCORPORATED PRODUCTS  
 COVERED BY U. S. AND FOREIGN PATENTS AND/OR PATENTS PENDING.

REVISIONS						
P	F	ZONE	LTR	DESCRIPTION	DATE	APPROVED
A	✓		A	REDWN & ADD-3 PER NPI C80-50	6/26/80	GB m±

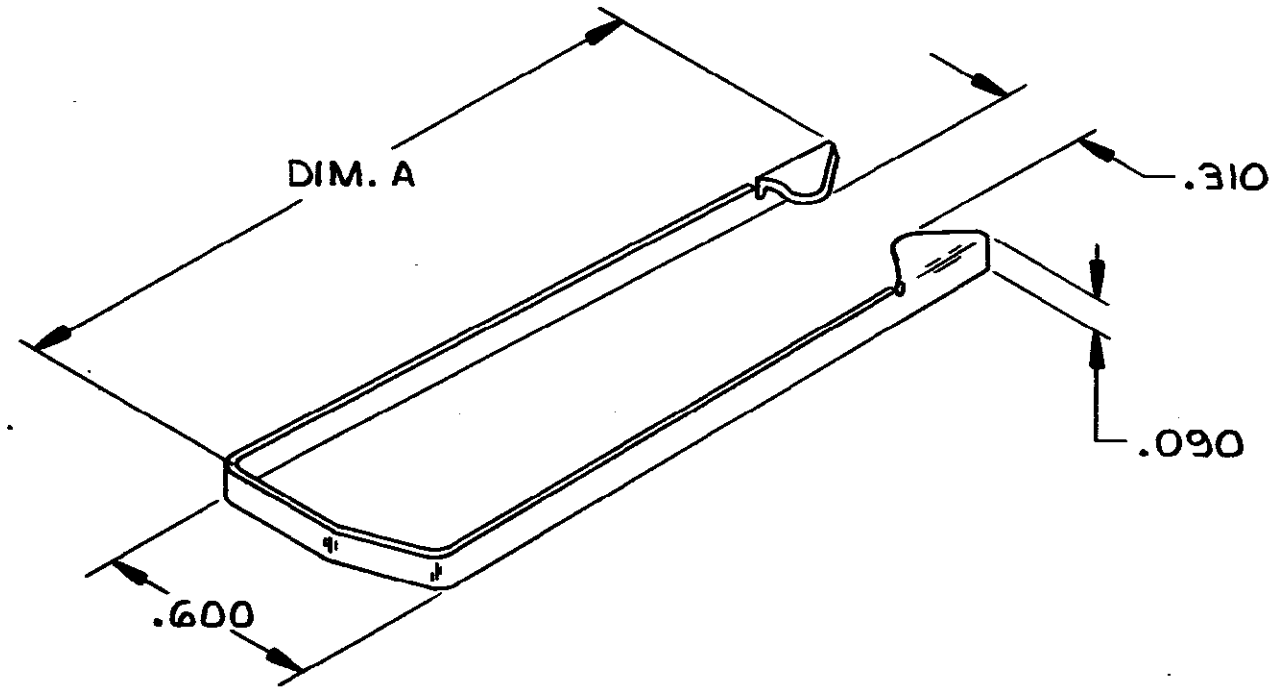

1. ALL DIMENSIONS SHOWN ARE FOR REFERENCE ONLY UNLESS OTHERWISE SPECIFIED.

2. MATERIAL: PASSIVATED STAINLESS STEEL.

B WAS 1228-77-8-1420

64	1.820	552723-3
14 & 24	.857	552723-2
36 & 50	1.338	552723-1
POSITIONS	DIM. A	PART NO

UNLESS OTHERWISE SPECIFIED DIMENSIONS ARE IN INCHES. TOLERANCES ON: DECIMALS ± # ANGLES ± #	CONTRACT NO 6-26-80	 AMP INCORPORATED Harrisburg, Pa.	
	DR <i>A. Bourne</i>		
MATERIAL 2	CHK <i>MD/mw</i> 6-27-80	APPD <i>B.G. White</i> 7/9/80	APPD <i>W. Somerville</i> 7/9/80
FINISH 2	DSGN APPD	OTHER APPD	SIZE <b>B</b> CODE IDENT NO <b>00779</b> DRAWING NO <b>552723</b>
		SCALE <b>2/1</b>	SHEET <b>1 OF 1</b>