

LOC		DIST		REVISIONS			
P	LTR	DESCRIPTION	DATE	DMN	APVD		
A		REV PER EC 0512-0302-05	15DEC05	BC	GS		
B		ECR-10-018652	10SEP10	SW	MQW		

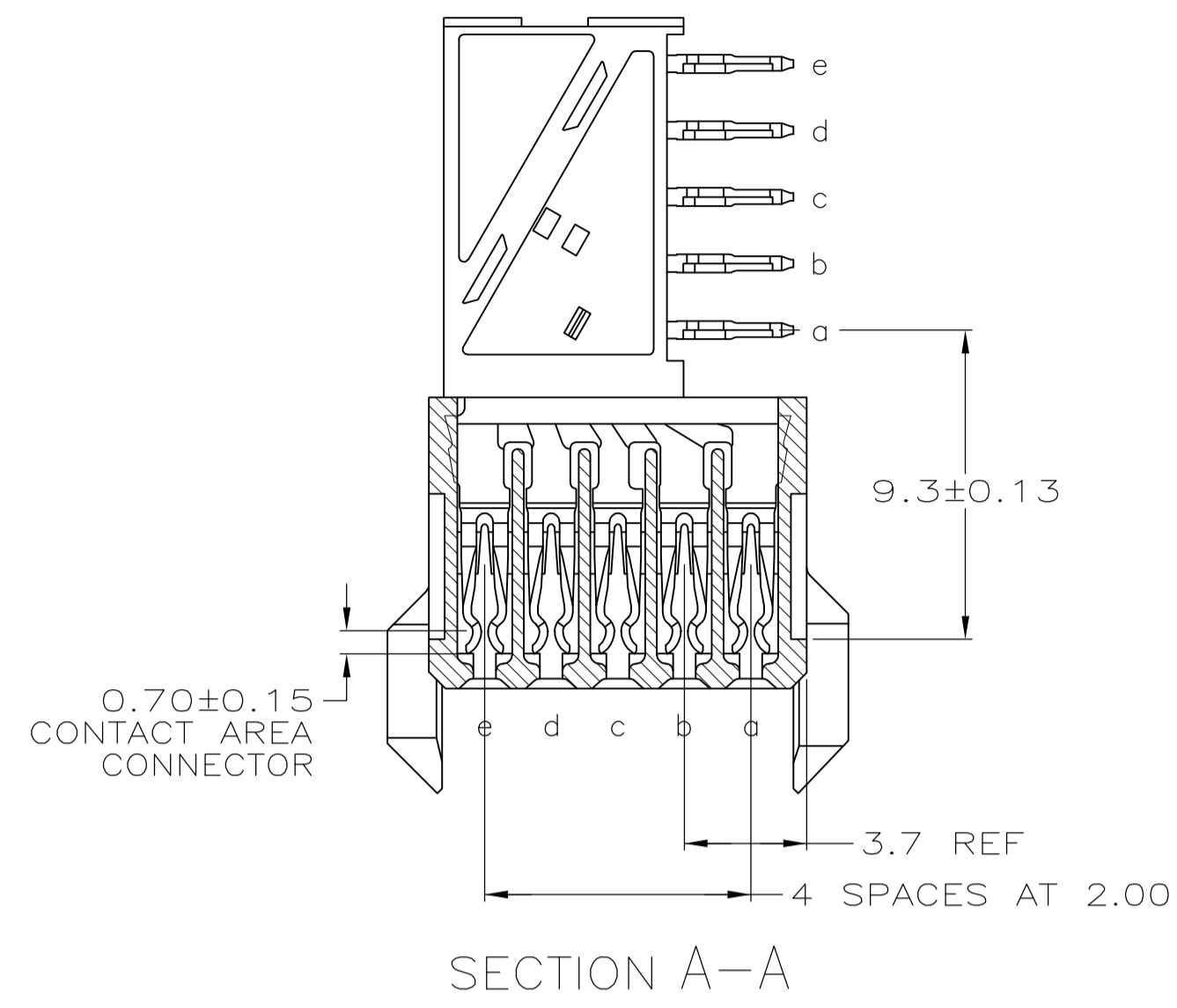

- 1 MATERIAL:
CONTACT: PHOSPHOR BRONZE.
HOUSING: GLASS-FILLED POLYESTER.
- 2 GENERAL PLATING SPECIFICATION: UNDERPLATING
(ENTIRE CONTACT): 1.27µm MIN NICKEL AND ACTION
PIN: 0.5µm MIN TIN.
FOR PLATING OF MATING SURFACES SEE APPLICABLE SPECIFICATION REFERENCE FOR EACH DASH NUMBER.
- 3 CONFORMS TO ALL TESTING ACCORDING TO IEC 61076-4-101 PERFORMANCE LEVEL 2.
- 4 CONFORMS TO ALL TESTING ACCORDING TO IEC 61076-4-101 PERFORMANCE LEVEL 1.
- 5 CONNECTOR TESTED AND QUALIFIED AGAINST TELCORDIA GR-1217-CORE QUALITY LEVEL 3, CENTRAL OFFICE APPLICATIONS.
- 6 CONNECTOR TESTED AND QUALIFIED AGAINST TELCORDIA GR-1217-CORE QUALITY LEVEL 3, UNCONTROLLED ENVIRONMENT APPLICATIONS.
- 7 CONNECTOR MARKED WITH PART NUMBER AND DATE CODE.
ADDITIONAL CHARACTERS OR MARKINGS, AS WELL AS THE LOCATION OF THE MARKINGS, MAY BE ADDED FOR TRACEABILITY BASED UPON MANUFACTURERS DISCRETION.
- 8 PLATED-THROUGH HOLES AT 2x2mm SQUARE GRID.
- 9 CONNECTOR LUBRICATED WITH BELCORE APPROVED LUBRICANT, TECHNICAL REFERENCE: TR-NWT-001217 ISSUE 1, SEP 1992.

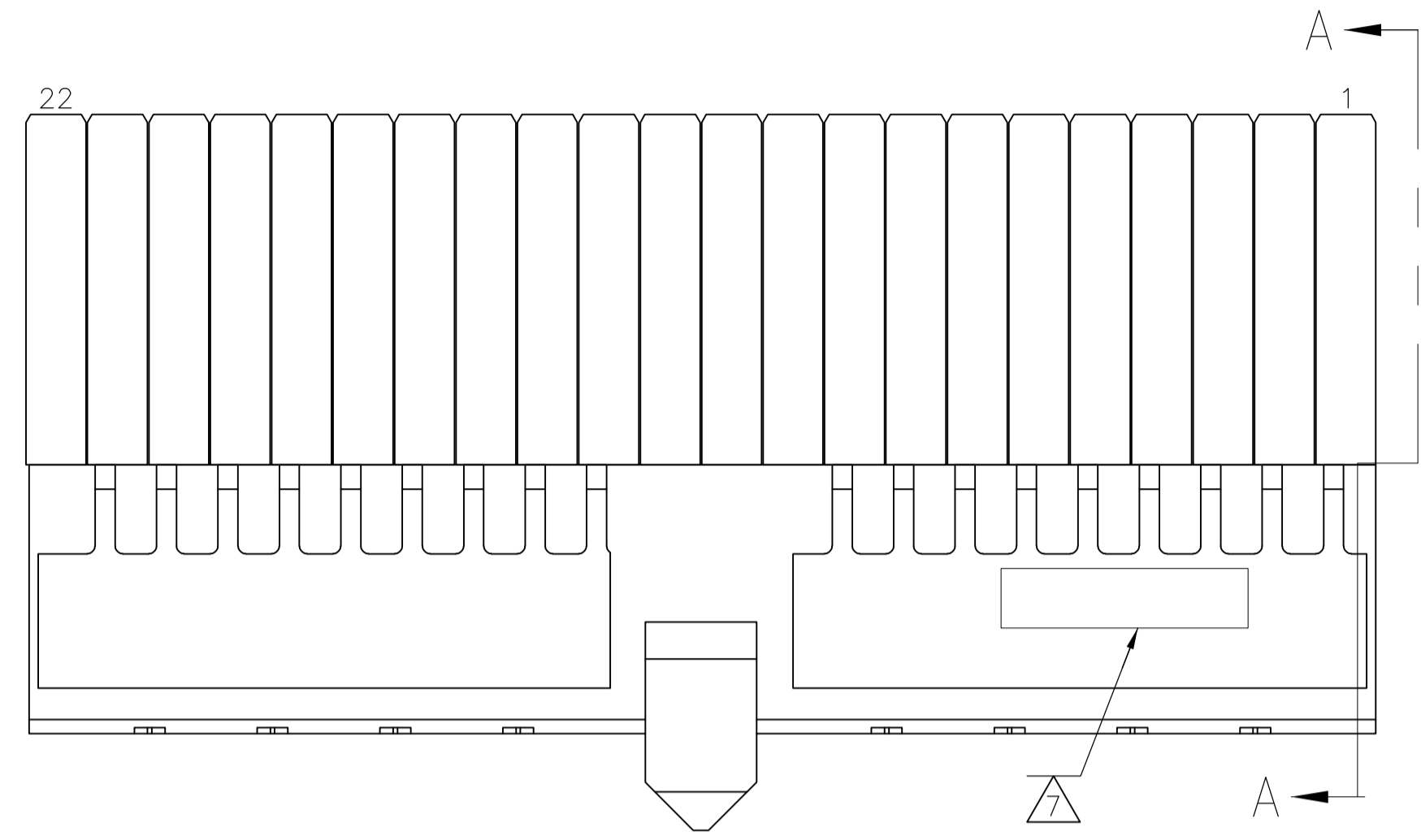
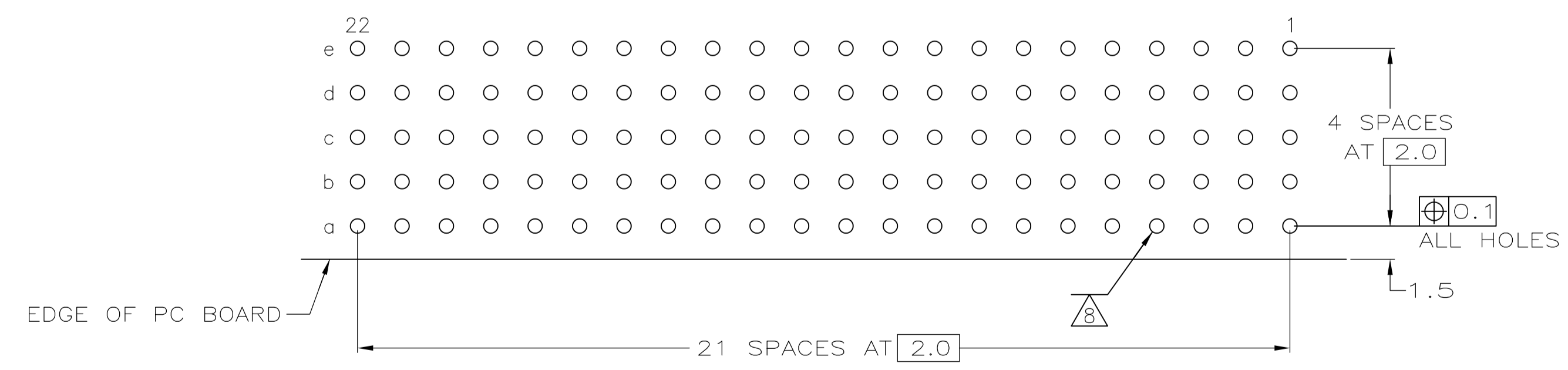
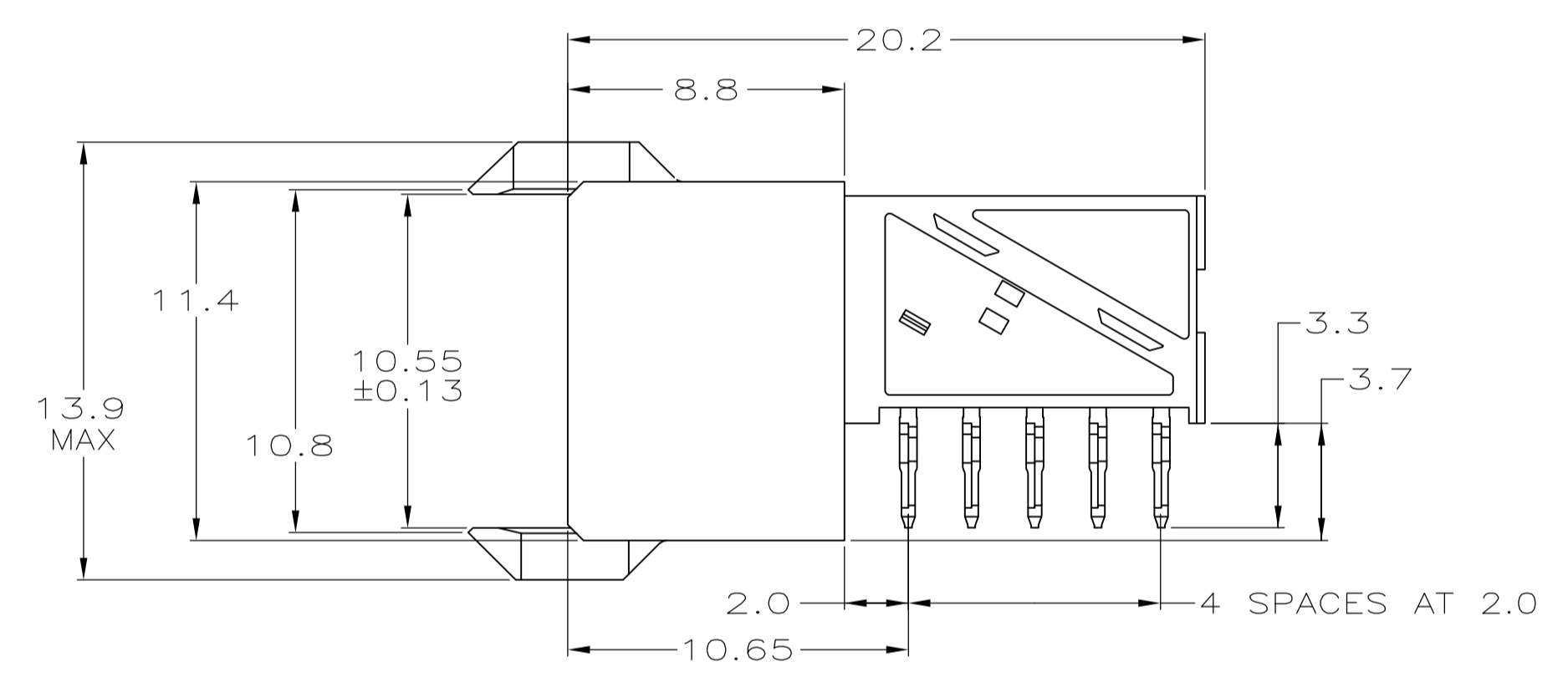
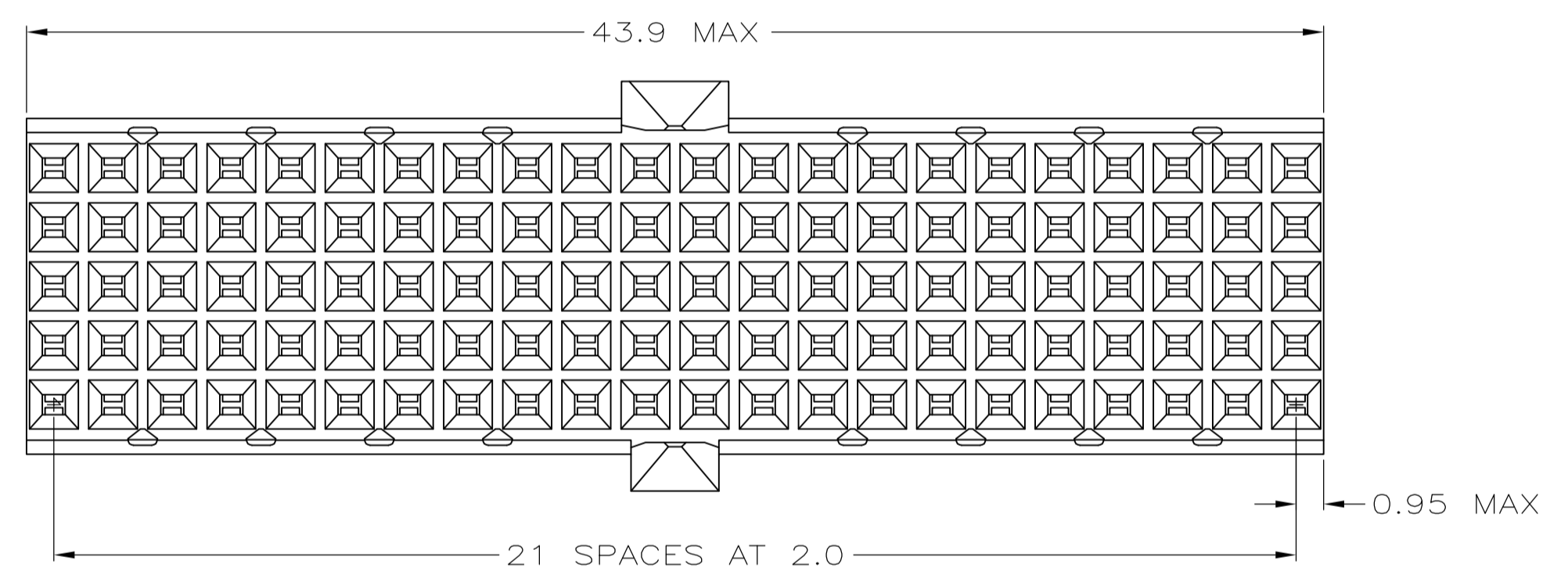

COMPONENT SIDE AS SHOWN
RECOMMENDED PCB HOLE LAYOUT

PLATED THRU HOLES PARAMETERS
REFERENCE APPLICATION SPECIFICATION

2/5/9	1-5646573-9
2/4/9	5646573-9
2/4/4	5646573-4
2/3/3	5646573-1
FINISH	PART NUMBER

THIS DRAWING IS A CONTROLLED DOCUMENT.		DIN B CARBO 29JUL05	Tyco Electronics Corporation Harrisburg, PA 17105-3608	
DIMENSIONS: mm		CHK G SKIPPER 29JUL05	NAME RECEPTACLE ASSEMBLY, Z-PACK 2mm HM, TYPE A/B	
TOLERANCES UNLESS OTHERWISE SPECIFIED:		APVD G SKIPPER 29JUL05	PRODUCT SPEC 108-19082	
0-PLC ±		APPLICATION SPEC 114-19029		
1-PLC ±0.1		SIZE A1		
2-PLC ±		CAGE CODE 00779		
3-PLC ±		DRAWING NO 5646573		
4-PLC ±		RESTRICTED TO		
FINISH SEE TABLE		WEIGHT		
1		CUSTOMER DRAWING		
		SCALE 5:1 SHEET 1 OF 1 REV B		