

PRODUCT NO.

SEE TABLE

Tous droits strictement réservés. Reproduction ou communication a des tiers int sous quelque forme que ce soit sans autorisation écrite du propriétaire. Property of c BERG ELECTRONICS. Droits de reproduction BERG ELECTRONICS by



All rights strictly reserved. Reproduction or issue to third parties in any form whatsoever is not permitted without written authority from the proprietor. Copyright BERG ELECTRONICS by

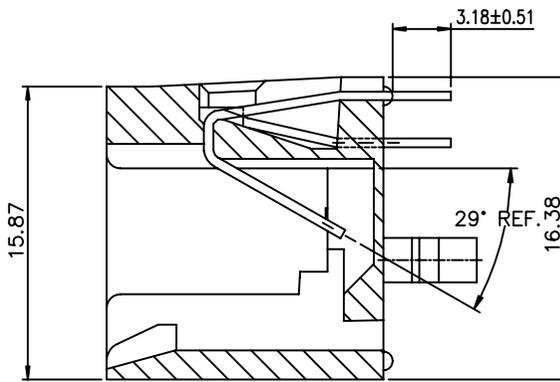
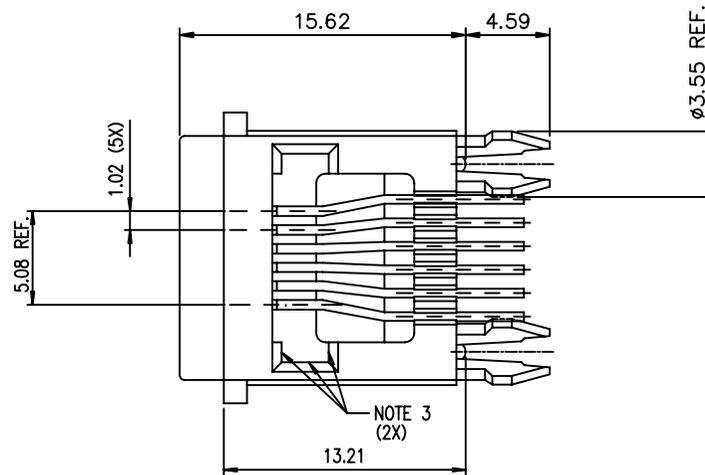
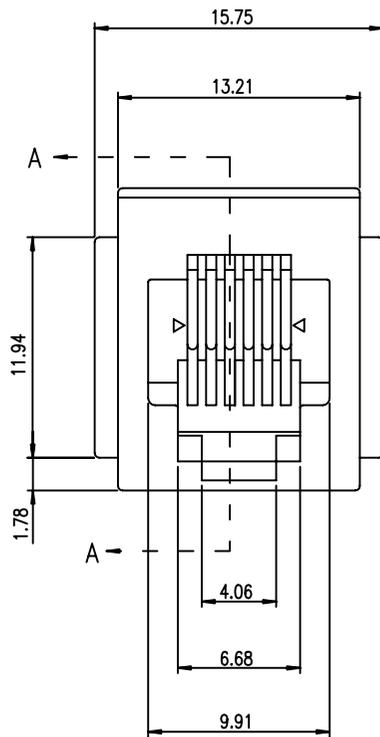

SECTION A-A

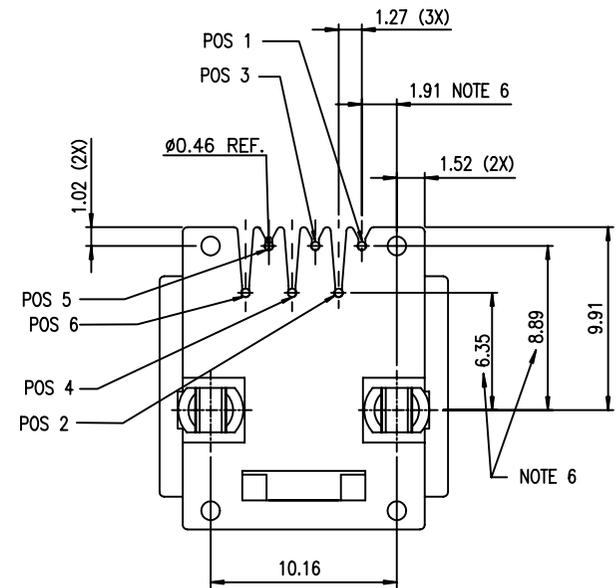

mat'l code				tolerance unless otherwise specified				CUSTOMER COPY		 www.fciconnect.com	
rev.	ecn no.	dr	date	linear	.0 ± 0.25		projection	title 6 POS VERT. SPECIAL PEG P.C.B. III MOD JACK ASSY product family MOD JACK code TWN size dwg no. 61837 sheet 1 OF 2			
H	N08-0170	SH	10/08/08		.00 ± 0.13						
B	T90021	M W	01/19/99		.000± 0.05						
C	N10059	WL	05/22/01	angles	± 2°						
D	N04-0023	D QIN	06/07/04	dr	C L FENG	02/21/97	unit				
E	N04-0125	YS	12/08/04	enrg	TONY CHIEN	02/21/97	mm/inch				
F	N05-0099	YS	04/01/05	chr	TONY CHIEN	02/21/97	scale				
G	N08-0097	SH	09/24/08	appd	JENN TSAO	02/21/97					
sheet	revision	C	C								
index	sheet	1	2								

Tous droits strictement réservés. Reproduction ou communication a des tiers int sous quelque forme que ce soit sans autorisation écrite du propriétaire. Property of c BERG ELECTRONICS. Droits de reproduction BERG ELECTRONICS by



All rights strictly reserved. Reproduction or issue to third parties in any for whatever is not permitted without written authority from the proprietor. Copyright BERG ELECTRONICS by

PRODUCT NO.	POSITIONS LOADED	HOUSING P/N	HSG COLOR
61837-X661	ALL	61836-001	BLACK
-X661LF		61836-011	BLACK
-X641	2,3,4,5	61836-001	BLACK
-X641LF		61836-011	BLACK
-X621	3,4	61836-001	BLACK
-X621LF		61836-011	BLACK
-X662	ALL	61836-002	GREY
-X662LF		61836-012	GREY
-X642	2,3,4,5	61836-002	GREY
-X642LF		61836-012	GREY
-X622	3,4	61836-002	GREY
-X622LF		61836-012	GREY
-X612LF	1,6	61836-002	GREY
-X612HLF		61836-012	GREY

LEAD FREE PRODUCT NO.
MEETS PIP PROCESS PRODUCT NO.

PLATING CODE X	PLATING
0	30 μ" / .76 μM G.X.T.
1	15 μ" / .38 μM GOLD (10)
3	30 μ" / .76 μM GOLD (10)
5	50 μ" / 1.27 μM GOLD

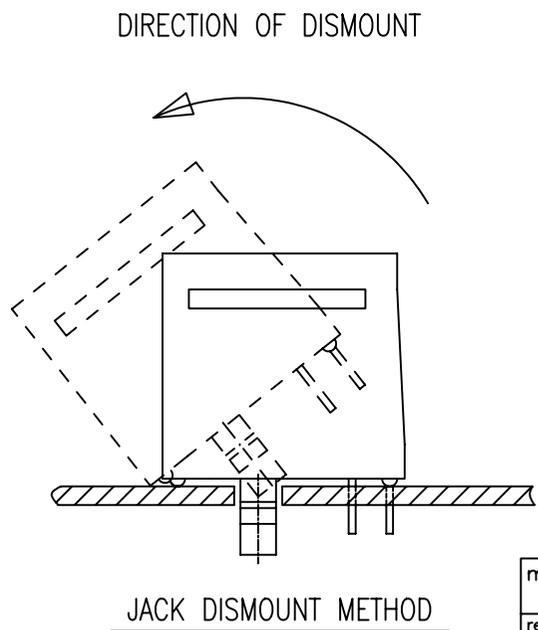
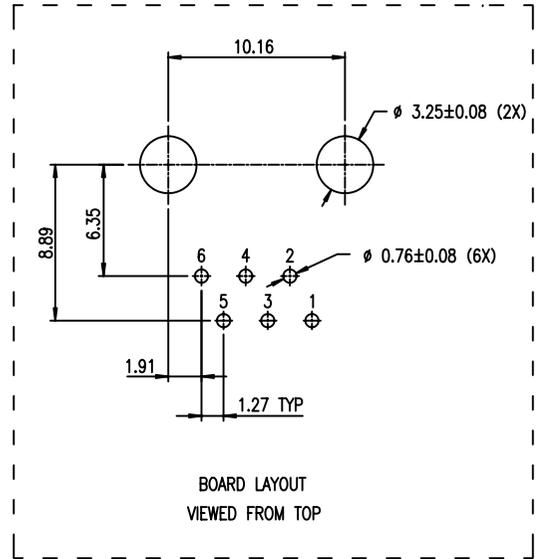

JACK DISMOUNT METHOD
DETAIL A
NOTE 5

- NOTES :
- P/N WITH DASH X6XX -NORMAL WAVE SOLDERING APPLICATION.
 - PACKAGING SPEC. GES-14-351 (USING TRAY).
 - SCRATCH MARKS ACCEPTABLE ON THESE SURFACES.
 - JACK IS FOR 1.57/.062 THICK PCB.
 - SHOULD THE JACK NEED TO BE DISMOUNTED FROM THE PCB. PLS REMOVE JACK AS PER RECOMMENDED METHOD HEREIN. (DETAIL A) NIPPING THE LEGS OF THE PEG TOGETHER IS DISALLOWED, OTHERWISE LEG BREAKAGE MAY OCCUR.
 - THESE DIMENSIONS ARE MEASURED FROM THE TOP OF THE PEG.
 - THIS PRODUCT MEETS EUROPEAN UNION DIRECTIVES AND OTHER COUNTRY REGULATIONS AS DESCRIBED IN GS-22-008
 - IF LF P/N PACKSGING MEETS GS-14-920 SPECIFICATION
 - THE HOUSING WILL WITHSTAND EXPOSURE TO 260° PEAK TEMPERATURE FOR 10 SECONDS IN A WAVE SOLDER APPLICATION WITH A 1.57mm MINIMUM THICK CIRCUIT BOARD
 - EQUIVALENT THICKNESS Au AND GXT PLATING HAVE SAME FUNCTION AND THEY ARE ALTERNATIVE BY THE CUSTOEMR .

mat'l code		tolerance unless otherwise specified		CUSTOMER COPY		 www.fciconnect.com	
rev.	ecn no.	dr	date	linear	.0 ± 0.25	projection	
H					.00 ± 0.13		
				angles	.000± 0.05		
				dr	± 2°		
				enr	C L FENG 02/20/97	unit	product family MOD JACK
				chr	TONY CHIEN 02/20/97	mm/inch	code
				appd	JENN TSAO 02/20/97	scale	TWN
						A3	sheet
						61837	2 OF
sheet	revision						
index	sheet						