

8 Mbit (1024K x 8/512K x 16) nvSRAM

Features

- 20 ns, 25 ns, and 45 ns access times
- Internally organized as 1024K x 8 (CY14B108L) or 512K x 16 (CY14B108N)
- Hands off automatic STORE on power down with only a small capacitor
- STORE to QuantumTrap nonvolatile elements initiated by software, device pin, or AutoStore on power down
- RECALL to SRAM initiated by software or power up
- Infinite Read, Write, and RECALL cycles
- 1 million STORE cycles to QuantumTrap
- 20 year data retention
- Single 3V +20%, -10% operation
- Industrial temperature
- 48-Ball FBGA and 44/54-Pin TSOP-II packages
- Pb-free and RoHS compliant

Functional Description

The Cypress CY14B108L/CY14B108N is a fast static RAM (SRAM), with a nonvolatile element in each memory cell. The memory is organized as 1024 Kbytes of 8 bits each or 512K words of 16 bits each. The embedded nonvolatile elements incorporate QuantumTrap technology, producing the world's most reliable nonvolatile memory. The SRAM provides infinite read and write cycles, while independent nonvolatile data resides in the highly reliable QuantumTrap cell. Data transfers from the SRAM to the nonvolatile elements (the STORE operation) takes place automatically at power down. On power up, data is restored to the SRAM (the RECALL operation) from the nonvolatile memory. Both the STORE and RECALL operations are also available under software control.

Logic Block Diagram^[1, 2, 3]

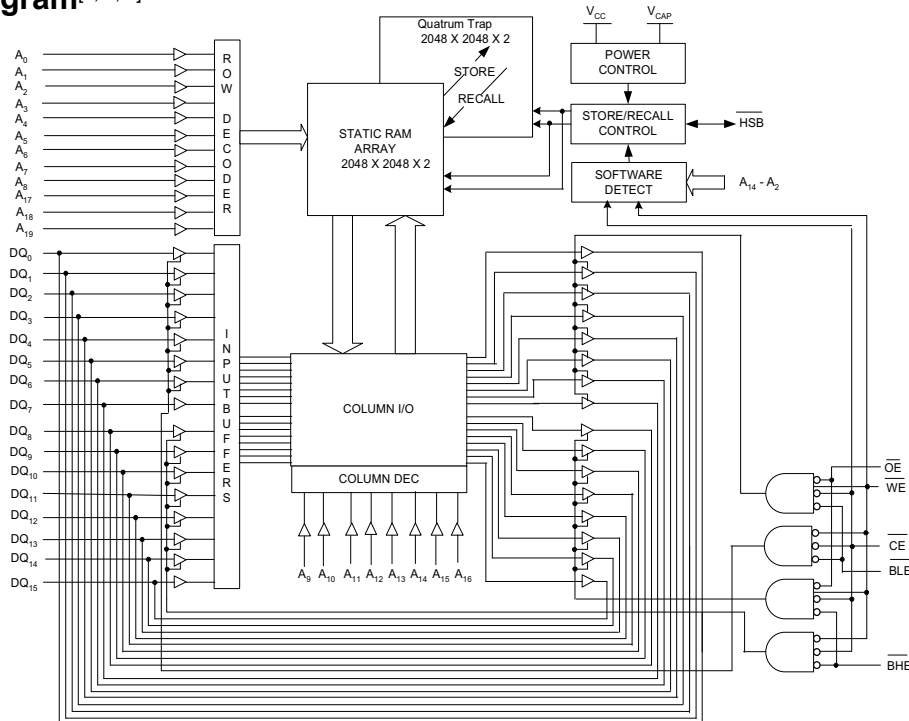

Notes

1. Address A₀ - A₁₉ for x8 configuration and Address A₀ - A₁₈ for x16 configuration.
2. Data DQ₀ - DQ₇ for x8 configuration and Data DQ₀ - DQ₁₅ for x16 configuration.
3. BHE and BLE are applicable for x16 configuration only.

Contents

Features	1	Capacitance	10
Functional Description	1	Thermal Resistance	10
Logic Block Diagram	1	AC Switching Characteristics	11
Contents	2	Switching Waveforms	11
Pinouts	3	AutoStore/Power Up RECALL	14
Device Operation	5	Switching Waveforms	14
SRAM Read	5	Software Controlled STORE/RECALL Cycle	15
SRAM Write	5	Switching Waveforms	15
AutoStore Operation	5	Hardware STORE Cycle	16
Hardware STORE Operation	5	Switching Waveforms	16
Hardware RECALL (Power Up)	6	Truth Table For SRAM Operations	17
Software STORE	6	For x8 Configuration	17
Software RECALL	6	For x16 Configuration	17
Preventing AutoStore	8	Part Numbering Nomenclature	18
Data Protection	8	Ordering Information	19
Noise Considerations	8	Package Diagrams	20
Best Practices	8	Document History Page	23
Maximum Ratings	9	Sales, Solutions, and Legal Information	24
Operating Range	9	Worldwide Sales and Design Support	24
DC Electrical Characteristics	9	Products	24
AC Test Conditions	10	PSoC Solutions	24
Data Retention and Endurance	10		

Pinouts

Figure 1. Pin Diagram - 48 FBGA

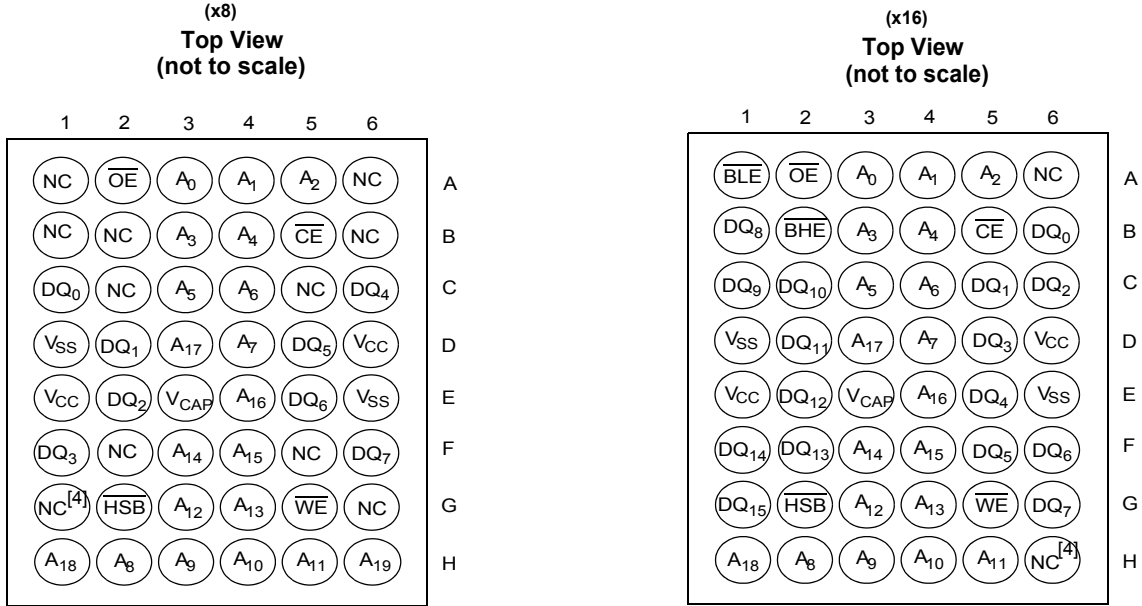
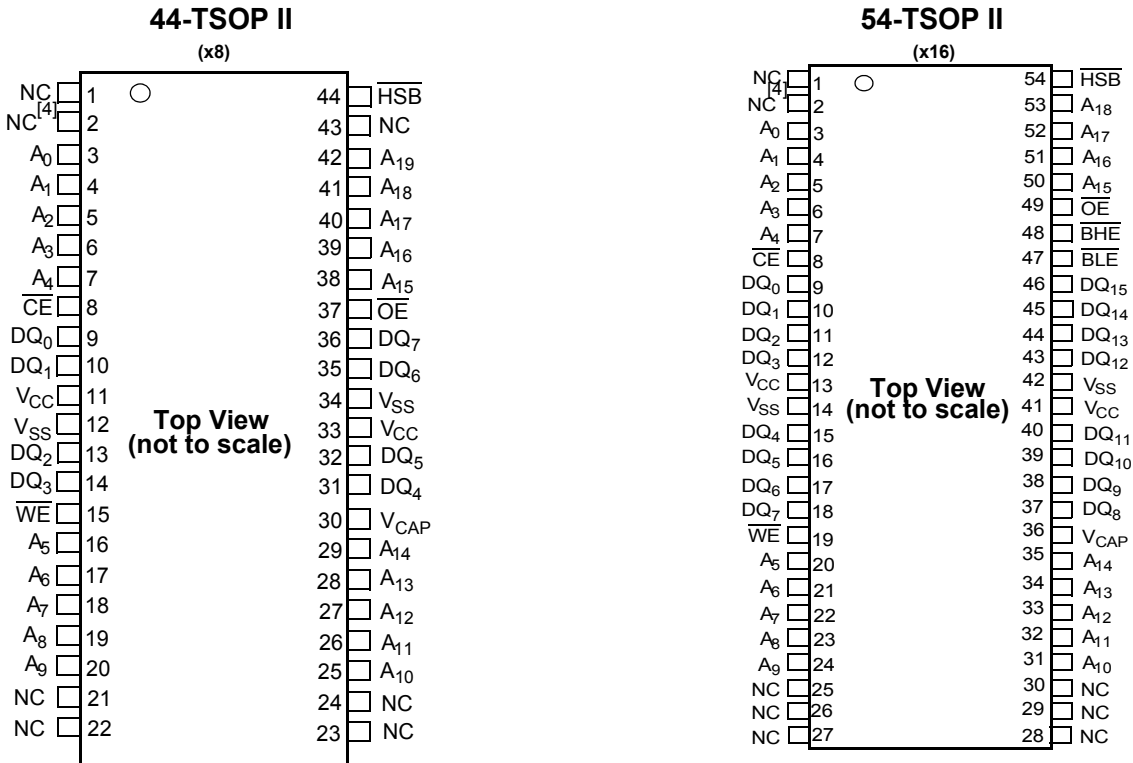

Figure 2. Pin Diagram - 44/54-Pin TSOP II



Note

4. Address expansion for 16 Mbit. NC pin not connected to die.

Table 1. Pin Definitions

Pin Name	I/O Type	Description
A ₀ – A ₁₉	Input	Address Inputs Used to Select one of the 1,048,576 bytes of the nvSRAM for x8 Configuration.
A ₀ – A ₁₈		Address Inputs Used to Select one of the 524,288 words of the nvSRAM for x16 Configuration.
DQ ₀ – DQ ₇	Input/Output	Bidirectional Data I/O Lines for x8 Configuration. Used as input or output lines depending on operation.
DQ ₀ – DQ ₁₅		Bidirectional Data I/O Lines for x16 Configuration. Used as input or output lines depending on operation.
\overline{WE}	Input	Write Enable Input, Active LOW. When selected LOW, data on the I/O pins is written to the specific address location.
\overline{CE}	Input	Chip Enable Input, Active LOW. When LOW, selects the chip. When HIGH, deselects the chip.
\overline{OE}	Input	Output Enable, Active LOW. The active LOW \overline{OE} input enables the data output buffers during read cycles. I/O pins are tristated on deasserting \overline{OE} HIGH.
\overline{BHE}	Input	Byte High Enable, Active LOW. Controls DQ ₁₅ - DQ ₈ .
\overline{BLE}	Input	Byte Low Enable, Active LOW. Controls DQ ₇ - DQ ₀ .
V _{SS}	Ground	Ground for the Device. Must be connected to the ground of the system.
V _{CC}	Power Supply	Power Supply Inputs to the Device.
\overline{HSB}	Input/Output	Hardware STORE Busy (HSB). When LOW this output indicates that a Hardware STORE is in progress. When pulled LOW external to the chip it initiates a nonvolatile STORE operation. After each Hardware and Software STORE operation, HSB is driven HIGH for a short time (t _{H_{HH}D}) with standard output high current and then a weak internal pull up resistor keeps this pin HIGH (external pull up resistor connection optional).
V _{CAP}	Power Supply	AutoStore Capacitor. Supplies power to the nvSRAM during power loss to store data from SRAM to nonvolatile elements.
NC	No Connect	No Connect. This pin is not connected to the die.

Device Operation

The CY14B108L/CY14B108N nvSRAM is made up of two functional components paired in the same physical cell. They are a SRAM memory cell and a nonvolatile QuantumTrap cell. The SRAM memory cell operates as a standard fast static RAM. Data in the SRAM is transferred to the nonvolatile cell (the STORE operation), or from the nonvolatile cell to the SRAM (the RECALL operation). Using this unique architecture, all cells are stored and recalled in parallel. During the STORE and RECALL operations, SRAM read and write operations are inhibited. The CY14B108L/CY14B108N supports infinite reads and writes similar to a typical SRAM. In addition, it provides infinite RECALL operations from the nonvolatile cells and up to 1 million STORE operations. See the “[Truth Table For SRAM Operations](#)” on page 17 for a complete description of read and write modes.

SRAM Read

The CY14B108L/CY14B108N performs a read cycle when \overline{CE} and \overline{OE} are LOW and \overline{WE} and HSB are HIGH. The address specified on pins A_{0-19} or A_{0-18} determines which of the 1,048,576 data bytes or 524,288 words of 16 bits each are accessed. Byte enables (\overline{BHE} , \overline{BLE}) determine which bytes are enabled to the output, in the case of 16-bit words. When the read is initiated by an address transition, the outputs are valid after a delay of t_{AA} (read cycle 1). If the read is initiated by \overline{CE} or \overline{OE} , the outputs are valid at t_{ACE} or at t_{DOE} , whichever is later (read cycle 2). The data output repeatedly responds to address changes within the t_{AA} access time without the need for transitions on any control input pins. This remains valid until another address change or until \overline{CE} or \overline{OE} is brought HIGH, or \overline{WE} or HSB is brought LOW.

SRAM Write

A write cycle is performed when \overline{CE} and \overline{WE} are LOW and HSB is HIGH. The address inputs must be stable before entering the write cycle and must remain stable until \overline{CE} or \overline{WE} goes HIGH at the end of the cycle. The data on the common I/O pins DQ_{0-15} are written into the memory if the data is valid t_{SD} before the end of a \overline{WE} controlled write or before the end of an \overline{CE} controlled write. The Byte Enable inputs (\overline{BHE} , \overline{BLE}) determine which bytes are written, in the case of 16-bit words. Keep \overline{OE} HIGH during the entire write cycle to avoid data bus contention on common I/O lines. If \overline{OE} is left LOW, internal circuitry turns off the output buffers t_{HZWE} after \overline{WE} goes LOW.

AutoStore Operation

The CY14B108L/CY14B108N stores data to the nvSRAM using one of the following three storage operations: Hardware STORE activated by HSB; Software STORE activated by an address sequence; AutoStore on device power down. The AutoStore operation is a unique feature of QuantumTrap technology and is enabled by default on the CY14B108L/CY14B108N.

During a normal operation, the device draws current from V_{CC} to charge a capacitor connected to the V_{CAP} pin. This stored charge is used by the chip to perform a single STORE operation. If the voltage on the V_{CC} pin drops below V_{SWITCH} , the part automatically disconnects the V_{CAP} pin from V_{CC} . A STORE operation is initiated with power provided by the V_{CAP} capacitor.

Note If the capacitor is not connected to V_{CAP} pin, AutoStore must be disabled using the soft sequence specified in [Preventing AutoStore](#) on page 8. In case AutoStore is enabled without a

capacitor on V_{CAP} pin, the device attempts an AutoStore operation without sufficient charge to complete the Store. This may corrupt the data stored in nvSRAM.

[Figure 3](#) shows the proper connection of the storage capacitor (V_{CAP}) for automatic STORE operation. Refer to [DC Electrical Characteristics](#) on page 9 for the size of V_{CAP} . The voltage on the V_{CAP} pin is driven to V_{CC} by a regulator on the chip. A pull up should be placed on \overline{WE} to hold it inactive during power up. This pull up is effective only if the \overline{WE} signal is tristate during power up. Many MPUs tristate their controls on power up. This should be verified when using the pull up. When the nvSRAM comes out of power-on-RECALL, the MPU must be active or the \overline{WE} held inactive until the MPU comes out of reset.

To reduce unnecessary nonvolatile STOREs, AutoStore and Hardware STORE operations are ignored unless at least one write operation has taken place since the most recent STORE or RECALL cycle. Software initiated STORE cycles are performed regardless of whether a write operation has taken place. The HSB signal is monitored by the system to detect if an AutoStore cycle is in progress.

Figure 3. AutoStore Mode

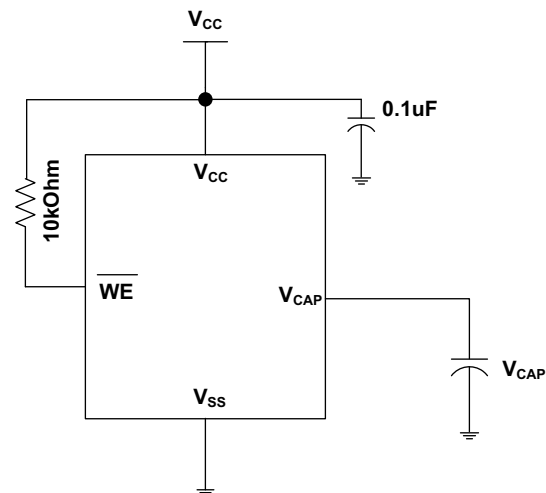

Hardware STORE Operation

The CY14B108L/CY14B108N provides the \overline{HSB} pin to control and acknowledge the STORE operations. Use the \overline{HSB} pin to request a Hardware STORE cycle. When the \overline{HSB} pin is driven LOW, the CY14B108L/CY14B108N conditionally initiates a STORE operation after t_{DELAY} . An actual STORE cycle only begins if a write to the SRAM has taken place since the last STORE or RECALL cycle. The \overline{HSB} pin also acts as an open drain driver (internal 100k Ω weak pull up resistor) that is internally driven LOW to indicate a busy condition when the STORE (initiated by any means) is in progress.

Note After each Hardware and Software STORE operation \overline{HSB} is driven HIGH for a short time (t_{HHHD}) with standard output high current and then remains HIGH by internal 100k Ω pull up resistor.

SRAM write operations that are in progress when $\overline{\text{HSB}}$ is driven LOW by any means are given time (t_{DELAY}) to complete before the STORE operation is initiated. However, any SRAM write cycles requested after $\overline{\text{HSB}}$ goes LOW are inhibited until $\overline{\text{HSB}}$ returns HIGH. In case the write latch is not set, $\overline{\text{HSB}}$ is not driven LOW by the CY14B108L/CY14B108N. But any SRAM read and write cycles are inhibited until $\overline{\text{HSB}}$ is returned HIGH by MPU or other external source.

During any STORE operation, regardless of how it is initiated, the CY14B108L/CY14B108N continues to drive the $\overline{\text{HSB}}$ pin LOW, releasing it only when the STORE is complete. After the STORE operation is completed, the CY14B108L/CY14B108N remains disabled until the $\overline{\text{HSB}}$ pin returns HIGH. Leave the $\overline{\text{HSB}}$ unconnected if it is not used.

Hardware RECALL (Power Up)

During power up or after any low power condition ($V_{\text{CC}} < V_{\text{SWITCH}}$), an internal RECALL request is latched. When V_{CC} again exceeds the sense voltage of V_{SWITCH} , a RECALL cycle is automatically initiated and takes t_{HRECALL} to complete. During this time, $\overline{\text{HSB}}$ is driven LOW by the $\overline{\text{HSB}}$ driver.

Software STORE

Transfer data from the SRAM to the nonvolatile memory with a software address sequence. The CY14B108L/CY14B108N Software STORE cycle is initiated by executing sequential $\overline{\text{CE}}$ controlled read cycles from six specific address locations in exact order. During the STORE cycle an erase of the previous nonvolatile data is first performed, followed by a program of the nonvolatile elements. After a STORE cycle is initiated, further input and output are disabled until the cycle is completed.

Because a sequence of READs from specific addresses is used for STORE initiation, it is important that no other read or write accesses intervene in the sequence, or the sequence is aborted and no STORE or RECALL takes place.

To initiate the Software STORE cycle, the following read sequence must be performed.

1. Read Address 0x4E38 Valid READ
2. Read Address 0xB1C7 Valid READ
3. Read Address 0x83E0 Valid READ
4. Read Address 0x7C1F Valid READ
5. Read Address 0x703F Valid READ
6. Read Address 0x8FC0 Initiate STORE Cycle

The software sequence may be clocked with $\overline{\text{CE}}$ controlled reads or $\overline{\text{OE}}$ controlled reads, with $\overline{\text{WE}}$ kept HIGH for all the six READ sequences. After the sixth address in the sequence is entered, the STORE cycle commences and the chip is disabled. $\overline{\text{HSB}}$ is driven LOW. After the t_{STORE} cycle time is fulfilled, the SRAM is activated again for the read and write operation.

Software RECALL

Transfer the data from the nonvolatile memory to the SRAM with a software address sequence. A Software RECALL cycle is initiated with a sequence of read operations in a manner similar to the Software STORE initiation. To initiate the RECALL cycle, the following sequence of $\overline{\text{CE}}$ controlled read operations must be performed.

1. Read Address 0x4E38 Valid READ
2. Read Address 0xB1C7 Valid READ
3. Read Address 0x83E0 Valid READ
4. Read Address 0x7C1F Valid READ
5. Read Address 0x703F Valid READ
6. Read Address 0x4C63 Initiate RECALL Cycle

Internally, RECALL is a two-step procedure. First, the SRAM data is cleared; then, the nonvolatile information is transferred into the SRAM cells. After the t_{RECALL} cycle time, the SRAM is again ready for read and write operations. The RECALL operation does not alter the data in the nonvolatile elements.

Table 2. Mode Selection

$\overline{\text{CE}}$	$\overline{\text{WE}}$	$\overline{\text{OE}}$	$\overline{\text{BHE}}, \overline{\text{BLE}}^{[3]}$	$\text{A}_{15} - \text{A}_0^{[5]}$	Mode	I/O	Power
H	X	X	X	X	Not Selected	Output High Z	Standby
L	H	L	L	X	Read SRAM	Output Data	Active
L	L	X	L	X	Write SRAM	Input Data	Active
L	H	L	X	0x4E38 0xB1C7 0x83E0 0x7C1F 0x703F 0x8B45	Read SRAM Read SRAM Read SRAM Read SRAM Read SRAM AutoStore Disable	Output Data Output Data Output Data Output Data Output Data Output Data	Active ^[6]
L	H	L	X	0x4E38 0xB1C7 0x83E0 0x7C1F 0x703F 0x4B46	Read SRAM Read SRAM Read SRAM Read SRAM Read SRAM AutoStore Enable	Output Data Output Data Output Data Output Data Output Data Output Data	Active ^[6]
L	H	L	X	0x4E38 0xB1C7 0x83E0 0x7C1F 0x703F 0x8FC0	Read SRAM Read SRAM Read SRAM Read SRAM Read SRAM Nonvolatile STORE	Output Data Output Data Output Data Output Data Output Data Output High Z	Active $\text{I}_{\text{CC}2}^{[6]}$
L	H	L	X	0x4E38 0xB1C7 0x83E0 0x7C1F 0x703F 0x4C63	Read SRAM Read SRAM Read SRAM Read SRAM Read SRAM Nonvolatile RECALL	Output Data Output Data Output Data Output Data Output Data Output High Z	Active ^[6]

Notes

- While there are 20 address lines on the CY14B108L (19 address lines on the CY14B108N), only the 13 address lines ($\text{A}_{14} - \text{A}_2$) are used to control software modes. Rest of the address lines are don't care.
- The six consecutive address locations must be in the order listed. $\overline{\text{WE}}$ must be HIGH during all six cycles to enable a nonvolatile cycle.

Preventing AutoStore

The AutoStore function is disabled by initiating an AutoStore disable sequence. A sequence of read operations is performed in a manner similar to the Software STORE initiation. To initiate the AutoStore disable sequence, the following sequence of CE controlled read operations must be performed:

1. Read address 0x4E38 Valid READ
2. Read address 0xB1C7 Valid READ
3. Read address 0x83E0 Valid READ
4. Read address 0x7C1F Valid READ
5. Read address 0x703F Valid READ
6. Read address 0x8B45 AutoStore Disable

The AutoStore is re-enabled by initiating an AutoStore enable sequence. A sequence of read operations is performed in a manner similar to the Software RECALL initiation. To initiate the AutoStore enable sequence, the following sequence of CE controlled read operations must be performed:

1. Read address 0x4E38 Valid READ
2. Read address 0xB1C7 Valid READ
3. Read address 0x83E0 Valid READ
4. Read address 0x7C1F Valid READ
5. Read address 0x703F Valid READ
6. Read address 0x4B46 AutoStore Enable

If the AutoStore function is disabled or re-enabled, a manual STORE operation (Hardware or Software) must be issued to save the AutoStore state through subsequent power down cycles. The part comes from the factory with AutoStore enabled.

Data Protection

The CY14B108L/CY14B108N protects data from corruption during low voltage conditions by inhibiting all externally initiated STORE and write operations. The low voltage condition is detected when $V_{CC} < V_{SWITCH}$. If the CY14B108L/CY14B108N is in a write mode (both CE and WE are LOW) at power up, after a RECALL or STORE, the write is inhibited until the SRAM is enabled after t_{LZHSB} (HSB to output active). This protects against inadvertent writes during power up or brown out conditions.

Noise Considerations

Refer to CY application note [AN1064](#).

Best Practices

nvSRAM products have been used effectively for over 15 years. While ease-of-use is one of the product's main system values, experience gained working with hundreds of applications has resulted in the following suggestions as best practices:

- The nonvolatile cells in this nvSRAM product are delivered from Cypress with 0x00 written in all cells. Incoming inspection routines at customer or contract manufacturer's sites sometimes reprogram these values. Final NV patterns are typically repeating patterns of AA, 55, 00, FF, A5, or 5A. End product's firmware should not assume an NV array is in a set programmed state. Routines that check memory content values to determine first time system configuration, cold or warm boot status, and so on should always program a unique NV pattern (that is, complex 4-byte pattern of 46 E6 49 53 hex or more random bytes) as part of the final system manufacturing test to ensure these system routines work consistently.
- Power up boot firmware routines should rewrite the nvSRAM into the desired state (for example, autoStore enabled). While the nvSRAM is shipped in a preset state, best practice is to again rewrite the nvSRAM into the desired state as a safeguard against events that might flip the bit inadvertently such as program bugs and incoming inspection routines.
- The V_{CAP} value specified in this data sheet includes a minimum and a maximum value size. Best practice is to meet this requirement and not exceed the maximum V_{CAP} value because the nvSRAM internal algorithm calculates V_{CAP} charge and discharge time based on this max V_{CAP} value. Customers that want to use a larger V_{CAP} value to make sure there is extra store charge and store time should discuss their V_{CAP} size selection with Cypress to understand any impact on the V_{CAP} voltage level at the end of a t_{RECALL} period.

Maximum Ratings

Exceeding maximum ratings may impair the useful life of the device. These user guidelines are not tested.

Storage Temperature -65°C to +150°C

Maximum Accumulated Storage Time

At 150°C Ambient Temperature.....1000h

At 85°C Ambient Temperature..... 20 Years

Ambient Temperature with

Power Applied -55°C to +150°C

Supply Voltage on V_{CC} Relative to GND-0.5V to 4.1V

Voltage Applied to Outputs

in High Z State-0.5V to V_{CC} + 0.5V

Input Voltage.....-0.5V to V_{CC} + 0.5V

Transient Voltage (<20 ns) on

Any Pin to Ground Potential -2.0V to V_{CC} + 2.0V

Package Power Dissipation

Capability (T_A = 25°C) 1.0W

Surface Mount Pb Soldering

Temperature (3 Seconds)..... +260°C

DC Output Current (1 output at a time, 1s duration).... 15 mA

Static Discharge Voltage..... > 2001V
(per MIL-STD-883, Method 3015)

Latch Up Current > 200 mA

Operating Range

Range	Ambient Temperature	V _{CC}
Industrial	-40°C to +85°C	2.7V to 3.6V

DC Electrical Characteristics

Over the Operating Range (V_{CC} = 2.7V to 3.6V)

Parameter	Description	Test Conditions	Min	Typ ^[7]	Max	Unit
V _{CC}	Power Supply		2.7	3.0	3.6	V
I _{CC1}	Average V _{CC} Current	t _{RC} = 20 ns t _{RC} = 25 ns t _{RC} = 45 ns Values obtained without output loads (I _{OUT} = 0 mA)			75 75 57	mA mA mA
I _{CC2}	Average V _{CC} Current during STORE	All Inputs Don't Care, V _{CC} = Max Average current for duration t _{STORE}			20	mA
I _{CC3}	Average V _{CC} Current at t _{RC} = 200 ns, V _{CC} (Typ), 25°C	All Inputs cycling at CMOS levels. Values obtained without output loads (I _{OUT} = 0 mA).		40		mA
I _{CC4}	Average V _{CAP} Current during AutoStore Cycle	All Inputs Don't Care. Average current for duration t _{STORE}			10	mA
I _{SB}	V _{CC} Standby Current	$\overline{CE} \geq (V_{CC} - 0.2V)$. V _{IN} ≤ 0.2V or ≥ (V _{CC} - 0.2V). Standby current level after nonvolatile cycle is complete. Inputs are static. f = 0 MHz.			10	mA
I _{IX} ^[8]	Input Leakage Current (except HSB)	V _{CC} = Max, V _{SS} ≤ V _{IN} ≤ V _{CC}	-2		+2	μA
	Input Leakage Current (for HSB)	V _{CC} = Max, V _{SS} ≤ V _{IN} ≤ V _{CC}	-200		+2	μA
I _{OZ}	Off-State Output Leakage Current	V _{CC} = Max, V _{SS} ≤ V _{OUT} ≤ V _{CC} , \overline{CE} or $\overline{OE} \geq V_{IH}$ or BHE/BLE ≥ V _{IH} or WE ≤ V _{IL}	-2		+2	μA
V _{IH}	Input HIGH Voltage		2.0		V _{CC} + 0.5	V
V _{IL}	Input LOW Voltage		V _{SS} - 0.5		0.8	V
V _{OH}	Output HIGH Voltage	I _{OUT} = -2 mA	2.4			V
V _{OL}	Output LOW Voltage	I _{OUT} = 4 mA			0.4	V
V _{CAP}	Storage Capacitor	Between V _{CAP} pin and V _{SS} , 5V Rated	122	150	360	μF

Notes

7. Typical values are at 25°C, V_{CC} = V_{CC} (Typ). Not 100% tested.

8. The HSB pin has I_{OUT} = -2 μA for V_{OH} of 2.4V when both active HIGH and LOW drivers are disabled. When they are enabled standard V_{OH} and V_{OL} are valid. This parameter is characterized but not tested.

Data Retention and Endurance

Parameter	Description	Min	Unit
DATA _R	Data Retention	20	Years
NV _C	Nonvolatile STORE Operations	1,000	K

Capacitance

In the following table, the capacitance parameters are listed.^[9]

Parameter	Description	Test Conditions	Max	Unit
C _{IN}	Input Capacitance	T _A = 25°C, f = 1 MHz, V _{CC} = V _{CC} (Typ)	14	pF
C _{OUT}	Output Capacitance		14	pF

Thermal Resistance

In the following table, the thermal resistance parameters are listed. ^[9]

Parameter	Description	Test Conditions	48-FBGA	44-TSOP II	54-TSOP II	Unit
Θ _{JA}	Thermal Resistance (Junction to Ambient)	Test conditions follow standard test methods and procedures for measuring thermal impedance, in accordance with EIA/JESD51.	28.82	31.11	30.73	°C/W
Θ _{JC}	Thermal Resistance (Junction to Case)		7.84	5.56	6.08	°C/W

Figure 4. AC Test Loads

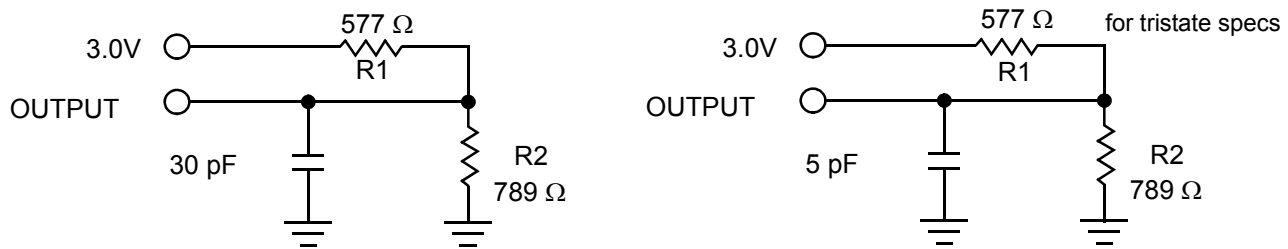

AC Test Conditions

Input Pulse Levels 0V to 3V
 Input Rise and Fall Times (10% - 90%) ≤3 ns
 Input and Output Timing Reference Levels 1.5V

Note

9. These parameters are guaranteed by design but not tested.

AC Switching Characteristics

Parameters		Description	20 ns		25 ns		45 ns		Unit
Cypress Parameters	Alt Parameters		Min	Max	Min	Max	Min	Max	
SRAM Read Cycle									
t_{ACE}	t_{ACS}	Chip Enable Access Time		20		25		45	ns
$t_{RC}^{[10]}$	t_{RC}	Read Cycle Time	20		25		45		ns
$t_{AA}^{[11]}$	t_{AA}	Address Access Time		20		25		45	ns
t_{DOE}	t_{OE}	Output Enable to Data Valid		10		12		20	ns
$t_{OHA}^{[11]}$	t_{OH}	Output Hold After Address Change	3		3		3		ns
$t_{LZCE}^{[9, 12]}$	t_{LZ}	Chip Enable to Output Active	3		3		3		ns
$t_{HZCE}^{[9, 12]}$	t_{HZ}	Chip Disable to Output Inactive		8		10		15	ns
$t_{LZOE}^{[9, 12]}$	t_{OLZ}	Output Enable to Output Active	0		0		0		ns
$t_{HZOE}^{[9, 12]}$	t_{OHZ}	Output Disable to Output Inactive		8		10		15	ns
$t_{PU}^{[9]}$	t_{PA}	Chip Enable to Power Active	0		0		0		ns
$t_{PD}^{[9]}$	t_{PS}	Chip Disable to Power Standby		20		25		45	ns
t_{DBE}	-	Byte Enable to Data Valid		10		12		20	ns
$t_{LZBE}^{[9]}$	-	Byte Enable to Output Active	0		0		0		ns
$t_{HZBE}^{[9]}$	-	Byte Disable to Output Inactive		8		10		15	ns
SRAM Write Cycle									
t_{WC}	t_{WC}	Write Cycle Time	20		25		45		ns
t_{PWE}	t_{WP}	Write Pulse Width	15		20		30		ns
t_{SCE}	t_{CW}	Chip Enable To End of Write	15		20		30		ns
t_{SD}	t_{DW}	Data Setup to End of Write	8		10		15		ns
t_{HD}	t_{DH}	Data Hold After End of Write	0		0		0		ns
t_{AW}	t_{AW}	Address Setup to End of Write	15		20		30		ns
t_{SA}	t_{AS}	Address Setup to Start of Write	0		0		0		ns
t_{HA}	t_{WR}	Address Hold After End of Write	0		0		0		ns
$t_{HZWE}^{[9, 12, 13]}$	t_{WZ}	Write Enable to Output Disable		8		10		15	ns
$t_{LZWE}^{[9, 12]}$	t_{OW}	Output Active after End of Write	3		3		3		ns
t_{BW}	-	Byte Enable to End of Write	15		20		30		ns

Switching Waveforms

Figure 5. SRAM Read Cycle #1: Address Controlled^[10, 11, 14]

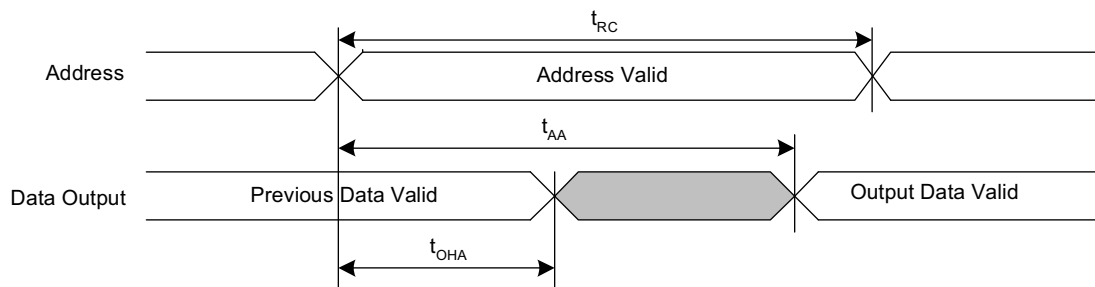

Notes

- 10. WE must be HIGH during SRAM read cycles.
- 11. Device is continuously selected with CE, OE and BHE / BLE LOW.
- 12. Measured ±200 mV from steady state output voltage.
- 13. If WE is LOW when CE goes LOW, the outputs remain in the high impedance state.
- 14. HSB must remain HIGH during READ and WRITE cycles.

Figure 6. SRAM Read Cycle #2: \overline{CE} and \overline{OE} Controlled^[3, 10, 14]

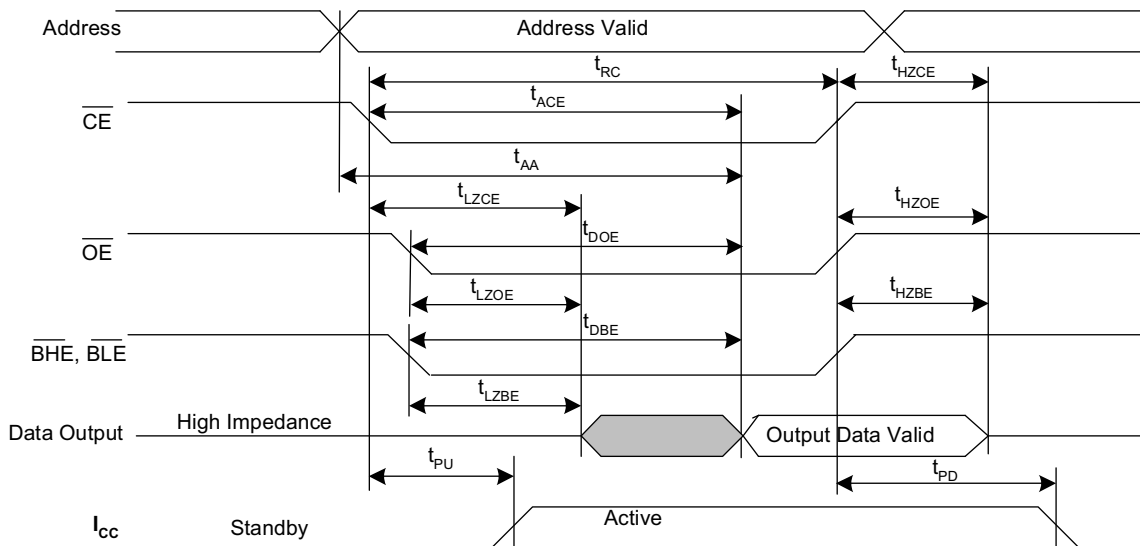
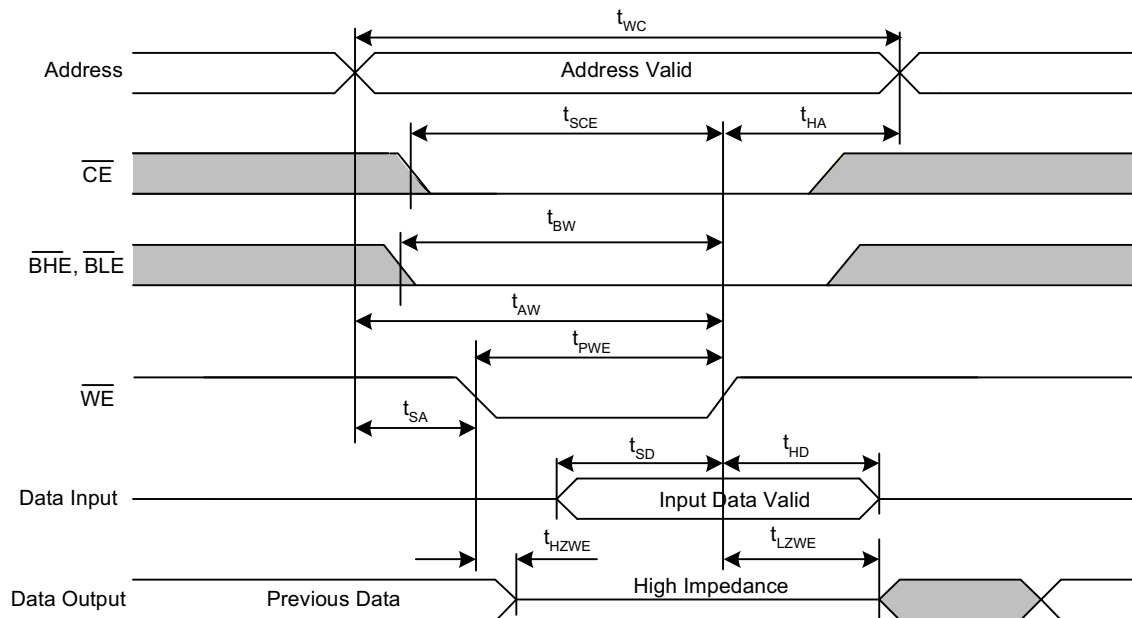

Figure 7. SRAM Write Cycle #1: \overline{WE} Controlled^[3, 13, 14, 15]



Note
15. \overline{CE} or \overline{WE} must be $\geq V_{IH}$ during address transitions.

Figure 8. SRAM Write Cycle #2: $\overline{\text{CE}}$ Controlled^[3, 13, 14, 15]

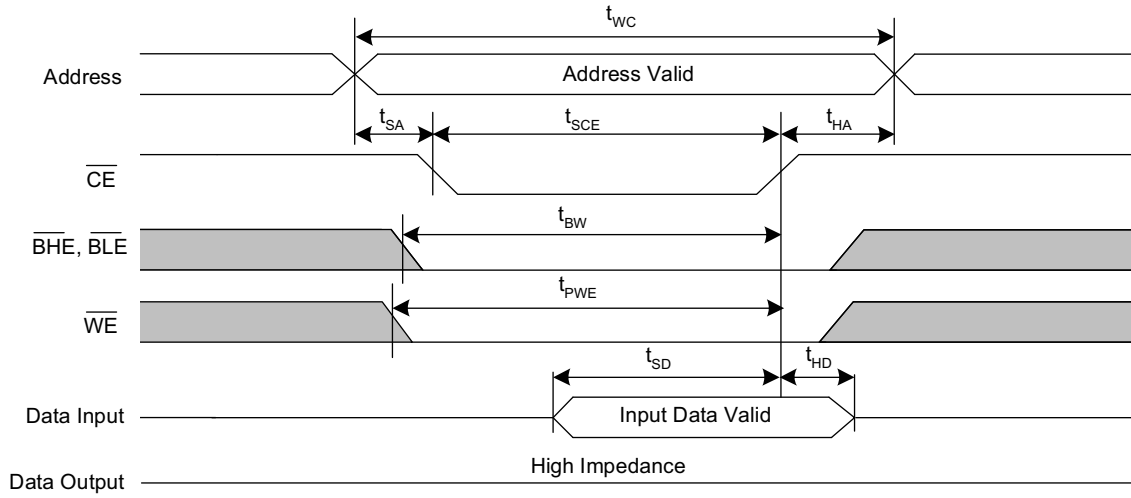
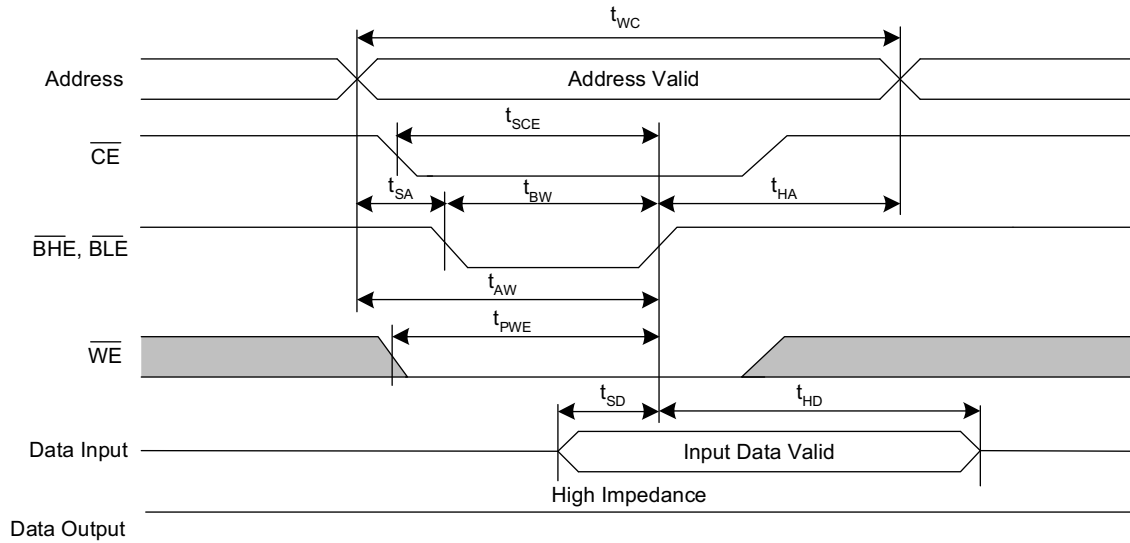

Figure 9. SRAM Write Cycle #3: $\overline{\text{BHE}}$ and $\overline{\text{BLE}}$ Controlled^[3, 13, 14, 15]



AutoStore/Power Up RECALL

Parameters	Description	20 ns		25 ns		45 ns		Unit
		Min	Max	Min	Max	Min	Max	
$t_{HRECALL}^{[16]}$	Power Up RECALL Duration		20		20		20	ms
$t_{STORE}^{[17]}$	STORE Cycle Duration		8		8		8	ms
$t_{DELAY}^{[18]}$	Time Allowed to Complete SRAM Write Cycle		20		25		25	ns
V_{SWITCH}	Low Voltage Trigger Level		2.65		2.65		2.65	V
$t_{VCCRRISE}^{[9]}$	VCC Rise Time	150		150		150		μ s
$V_{HDIS}^{[9]}$	HSB Output Disable Voltage		1.9		1.9		1.9	V
$t_{LZHSB}^{[9]}$	HSB To Output Active Time		5		5		5	μ s
$t_{HHHD}^{[9]}$	HSB High Active Time		500		500		500	ns

Switching Waveforms

Figure 10. AutoStore or Power Up RECALL^[19]

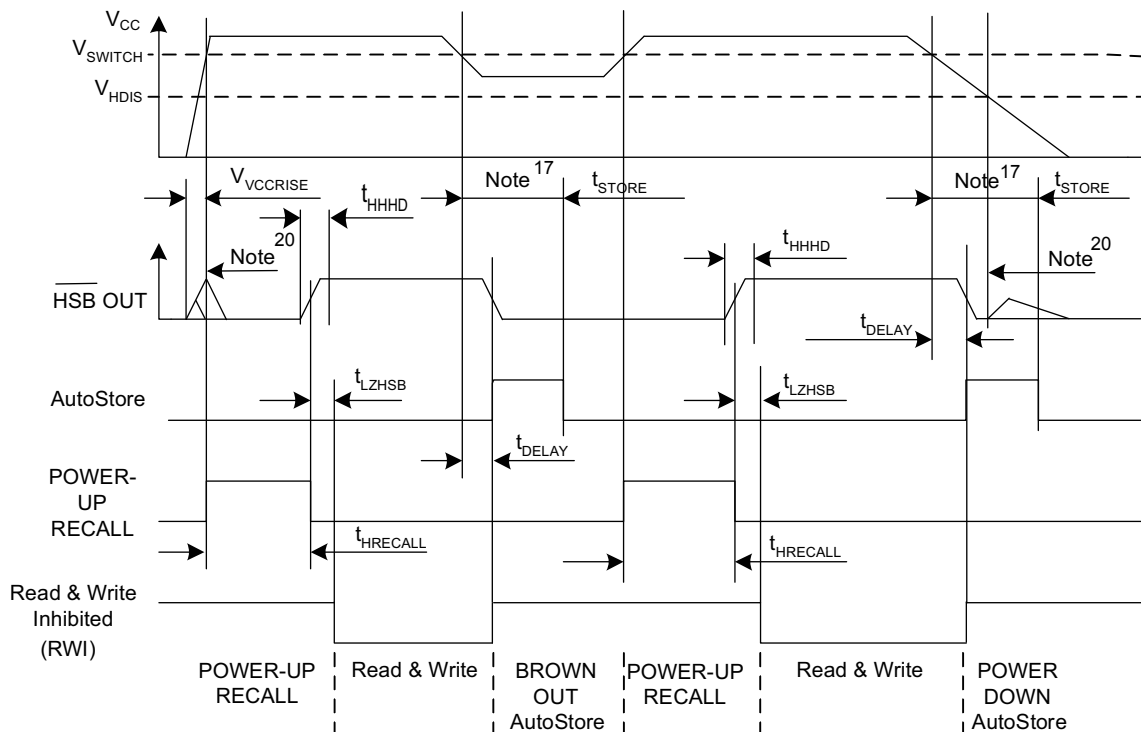

Notes

- 16. $t_{HRECALL}$ starts from the time V_{CC} rises above V_{SWITCH} .
- 17. If an SRAM write has not taken place since the last nonvolatile cycle, no AutoStore or Hardware STORE takes place.
- 18. On a Hardware STORE and AutoStore initiation, SRAM write operation continues to be enabled for time t_{DELAY} .
- 19. Read and Write cycles are ignored during STORE, RECALL, and while V_{CC} is below V_{SWITCH} .
- 20. During power up and power down, HSB glitches only when HSB pin is pulled up through an external resistor.

Software Controlled STORE/RECALL Cycle

In the following table, the software controlled STORE and RECALL cycle parameters are listed.^[21, 22]

Parameters	Description	20 ns		25 ns		45 ns		Unit
		Min	Max	Min	Max	Min	Max	
t_{RC}	STORE/RECALL Initiation Cycle Time	20		25		45		ns
t_{SA}	Address Setup Time	0		0		0		ns
t_{CW}	Clock Pulse Width	15		20		30		ns
t_{HA}	Address Hold Time	0		0		0		ns
t_{RECALL}	RECALL Duration		200		200		200	μ s

Switching Waveforms

Figure 11. \overline{CE} and \overline{OE} Controlled Software STORE/RECALL Cycle^[22]

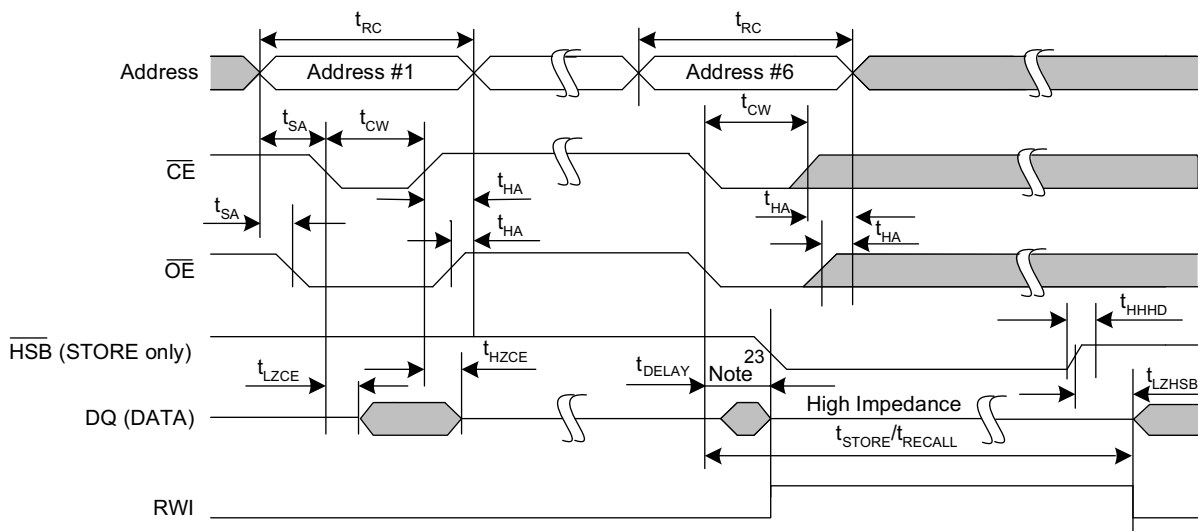
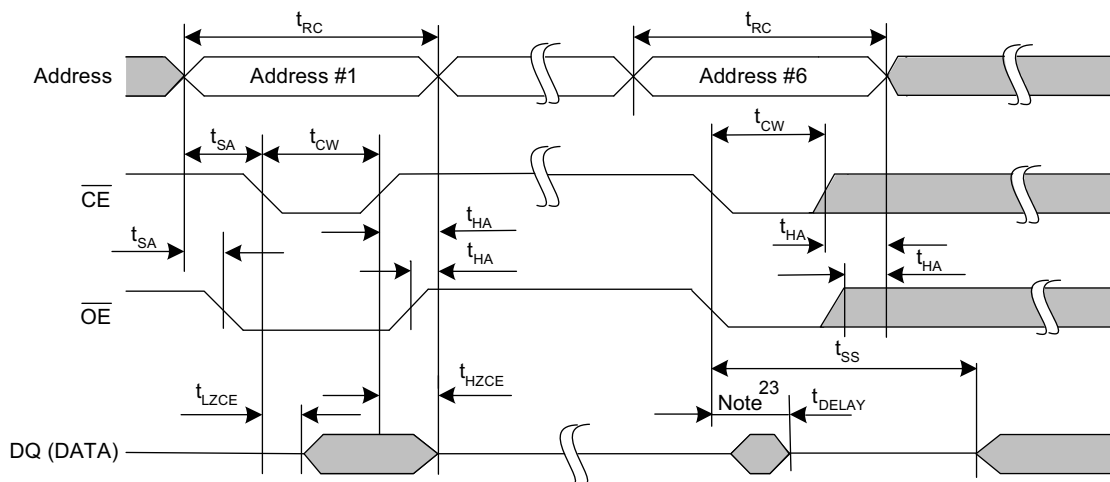

Figure 12. Autostore Enable/Disable Cycle



Notes

21. The software sequence is clocked with \overline{CE} controlled or \overline{OE} controlled reads.

22. The six consecutive addresses must be read in the order listed in Table 2 on page 7. \overline{WE} must be HIGH during all six consecutive cycles.

23. DQ output data at the sixth read may be invalid since the output is disabled at t_{DELAY} time.

Hardware STORE Cycle

Parameters	Description	20 ns		25 ns		45 ns		Unit
		Min	Max	Min	Max	Min	Max	
t_{DHSB}	HSB To Output Active Time when write latch not set		20		25		25	ns
t_{PHSB}	Hardware STORE Pulse Width	15		15		15		ns
$t_{SS}^{[24, 25]}$	Soft Sequence Processing Time		100		100		100	μ s

Switching Waveforms

Figure 13. Hardware STORE Cycle^[17]

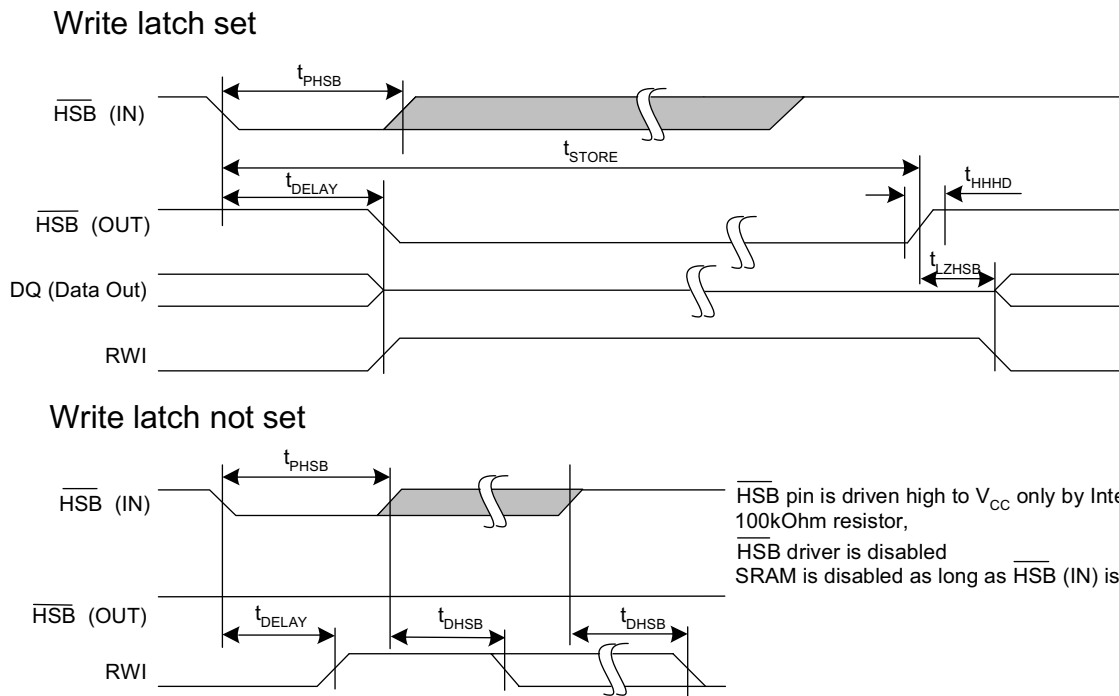
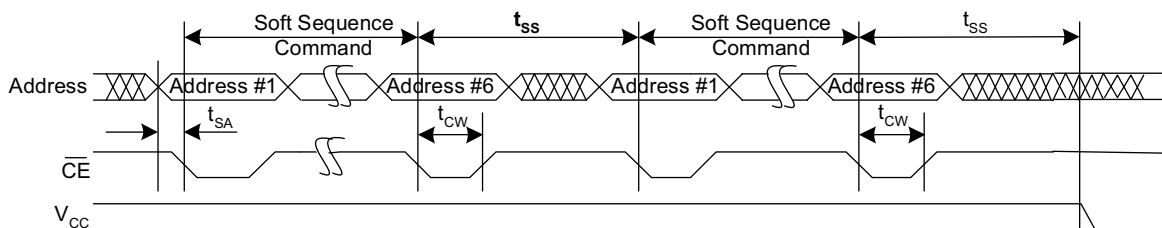

Figure 14. Soft Sequence Processing^[24, 25]



Notes

- 24. This is the amount of time it takes to take action on a soft sequence command. Vcc power must remain HIGH to effectively register command.
- 25. Commands such as STORE and RECALL lock out I/O until operation is complete which further increases this time. See the specific command.

Truth Table For SRAM Operations

HSB should remain HIGH for SRAM Operations.

For x8 Configuration

CE	WE	OE	Inputs/Outputs ^[2]	Mode	Power
H	X	X	High Z	Deselect/Power down	Standby
L	H	L	Data Out (DQ ₀ -DQ ₇);	Read	Active
L	H	H	High Z	Output Disabled	Active
L	L	X	Data in (DQ ₀ -DQ ₇);	Write	Active

For x16 Configuration

CE	WE	OE	BHE ^[3]	BLE ^[3]	Inputs/Outputs ^[2]	Mode	Power
H	X	X	X	X	High Z	Deselect/Power down	Standby
L	X	X	H	H	High Z	Output Disabled	Active
L	H	L	L	L	Data Out (DQ ₀ -DQ ₁₅)	Read	Active
L	H	L	H	L	Data Out (DQ ₀ -DQ ₇); DQ ₈ -DQ ₁₅ in High Z	Read	Active
L	H	L	L	H	Data Out (DQ ₈ -DQ ₁₅); DQ ₀ -DQ ₇ in High Z	Read	Active
L	H	H	L	L	High Z	Output Disabled	Active
L	H	H	H	L	High Z	Output Disabled	Active
L	H	H	L	H	High Z	Output Disabled	Active
L	L	X	L	L	Data In (DQ ₀ -DQ ₁₅)	Write	Active
L	L	X	H	L	Data In (DQ ₀ -DQ ₇); DQ ₈ -DQ ₁₅ in High Z	Write	Active
L	L	X	L	H	Data In (DQ ₈ -DQ ₁₅); DQ ₀ -DQ ₇ in High Z	Write	Active

Part Numbering Nomenclature

CY 14 B 108 L-ZSP 20 X I T

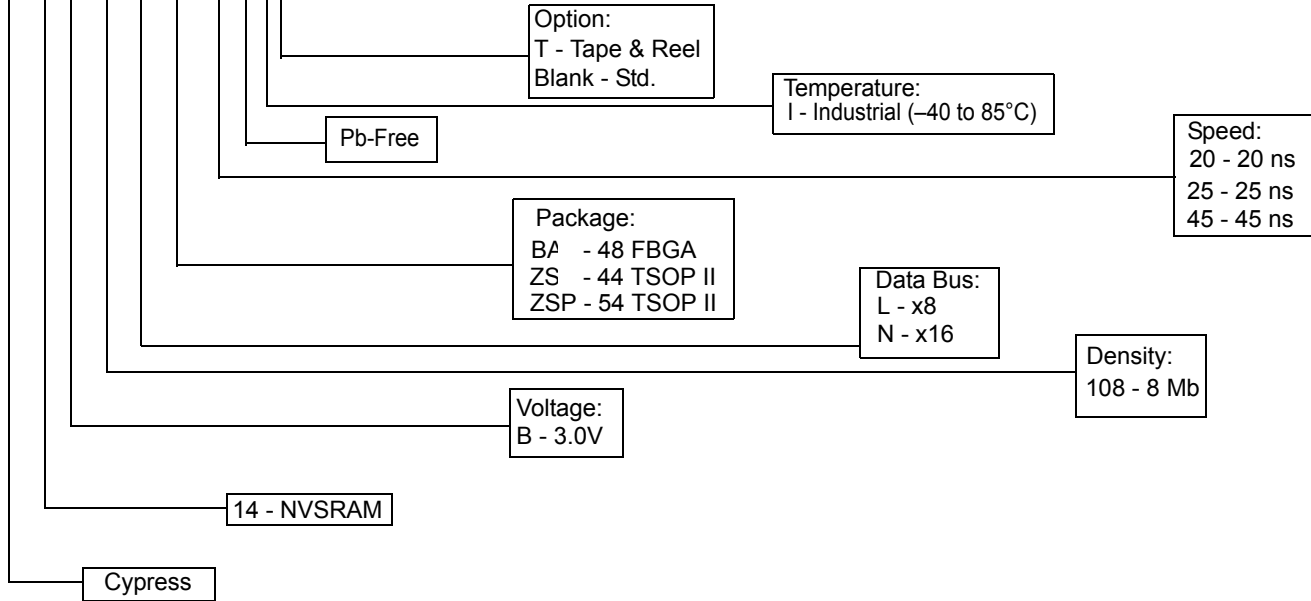

Ordering Information

Speed (ns)	Ordering Code	Package Diagram	Package Type	Operating Range
20	CY14B108L-ZS20XIT	51-85087	44-pin TSOP II	Industrial
	CY14B108L-ZS20XI	51-85087	44-pin TSOP II	
25	CY14B108L-ZS25XIT	51-85087	44-pin TSOP II	
	CY14B108L-ZS25XI	51-85087	44-pin TSOP II	
	CY14B108L-BA25XIT	51-85128	48-ball FBGA	
	CY14B108L-BA25XI	51-85128	48-ball FBGA	
	CY14B108N-BA25XIT	51-85128	48-ball FBGA	
	CY14B108N-BA25XI	51-85128	48-ball FBGA	
	CY14B108N-ZSP25XIT	51-85160	54-pin TSOP II	
	CY14B108N-ZSP25XI	51-85160	54-pin TSOP II	
45	CY14B108L-ZS45XIT	51-85087	44-pin TSOP II	
	CY14B108L-ZS45XI	51-85087	44-pin TSOP II	
	CY14B108L-BA45XIT	51-85128	48-ball FBGA	
	CY14B108L-BA45XI	51-85128	48-ball FBGA	
	CY14B108N-BA45XIT	51-85128	48-ball FBGA	
	CY14B108N-BA45XI	51-85128	48-ball FBGA	
	CY14B108N-ZSP45XIT	51-85160	54-pin TSOP II	
	CY14B108N-ZSP45XI	51-85160	54-pin TSOP II	

All the above parts are Pb-free.

Package Diagrams

Figure 15. 44-Pin TSOP II (51-85087)

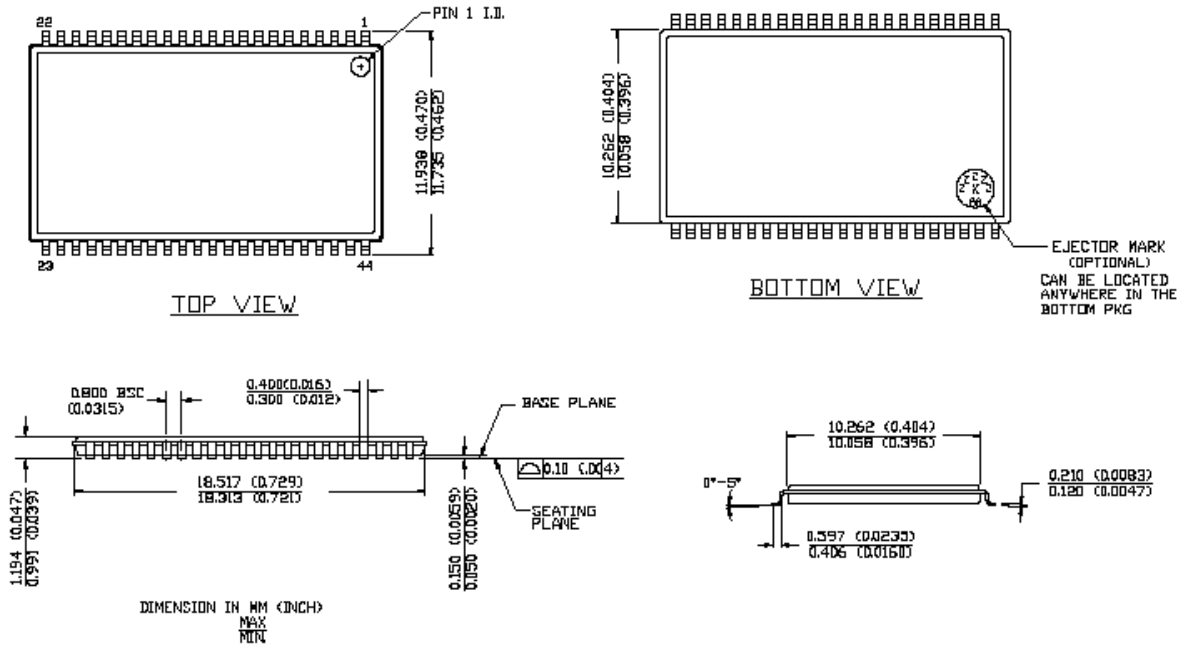

51-85087 *C

Package Diagrams (continued)

Figure 16. 48-Ball FBGA - 6 mm x 10 mm x 1.2 mm (51-85128)

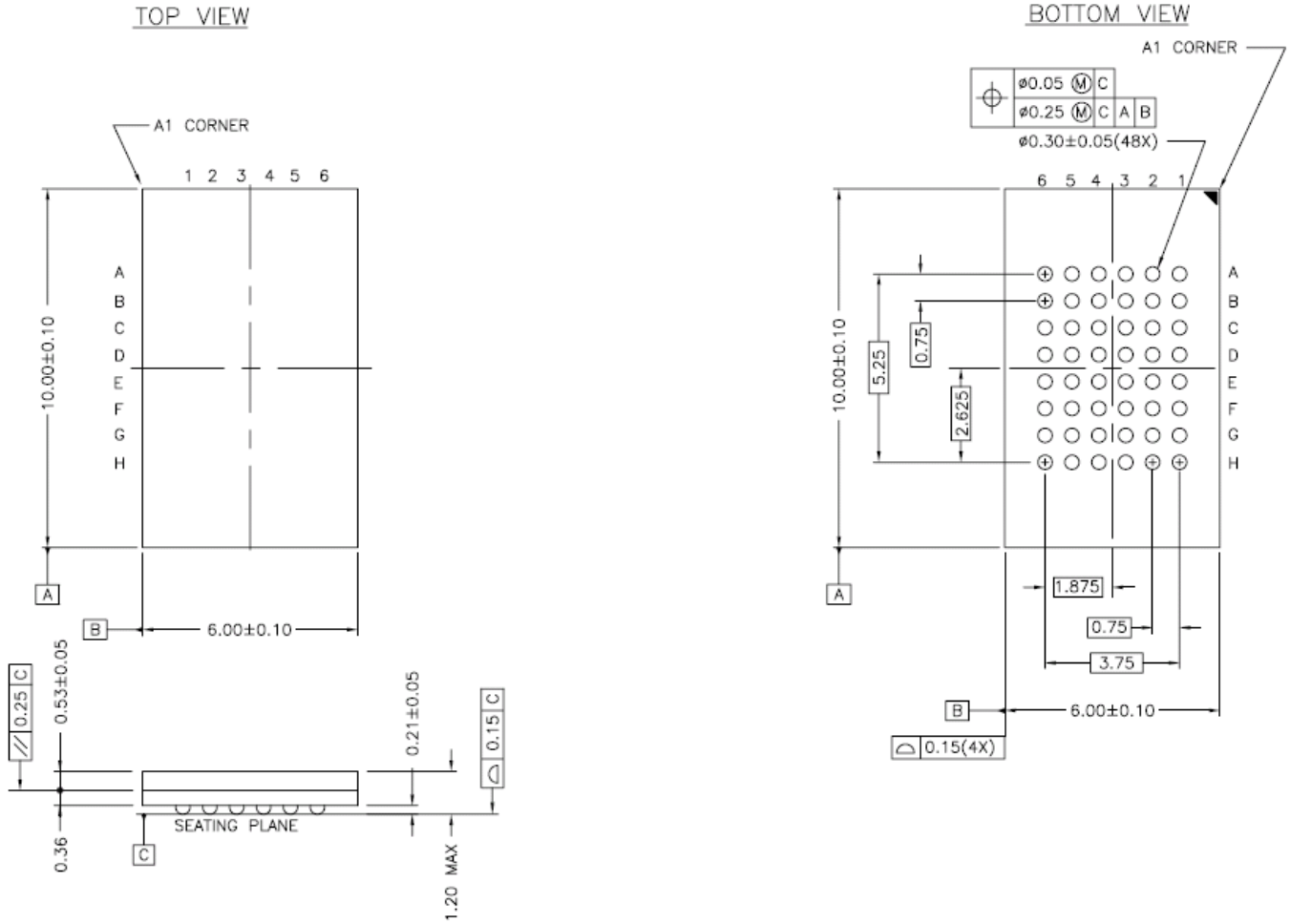

51-85128 *E

Package Diagrams (continued)

Figure 17. 54-Pin TSOP II (51-85160)

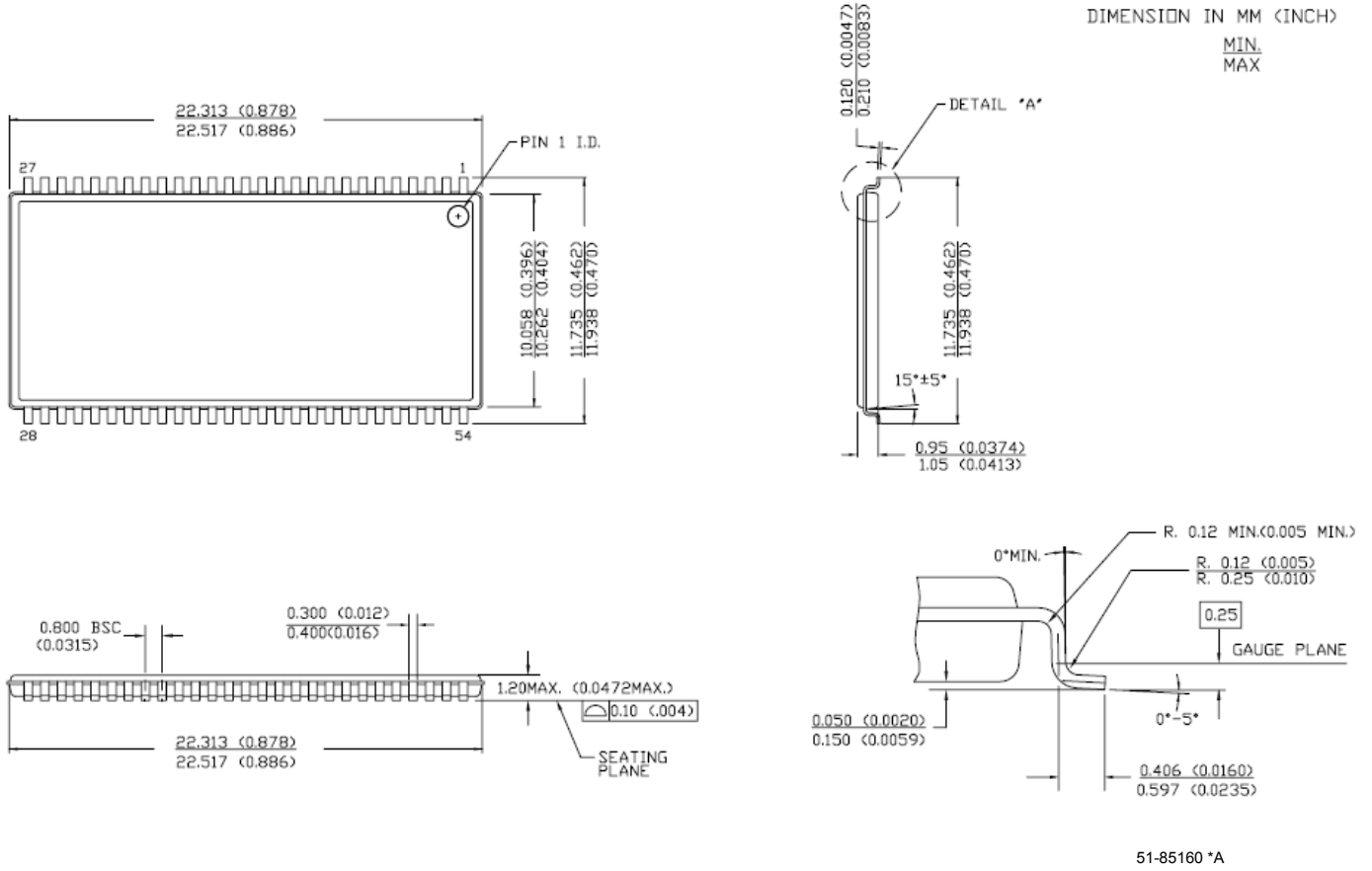

Document History Page

Document Title: CY14B108L, CY14B108N 8 Mbit (1024K x 8/512K x 16) nvSRAM				
Document Number: 001-45523				
Rev.	ECN No.	Orig. of Change	Submission Date	Description of Change
**	2428826	GVCH	See ECN	New Data Sheet
*A	2520023	GVCH/PYRS	06/23/08	Updated I _{CC1} for t _{RC} =20ns, 25ns and 45ns access speed for both industrial and Commercial temperature Grade Updated Thermal resistance values for 48-FBGA,44-TSOP II and 54-TSOP II packages Changed t _{CW} value from 16ns to 15ns
*B	2676670	GVCH/PYRS	03/20/2009	Added maximum accumulated storage time for 150°C and 85°C Temperature Added best practices Changed I _{CC2} from 12mA to 20mA Changed I _{CC3} from 38mA to 40mA Changed I _{CC4} from 12mA to 10mA Changed I _{SB} from 6mA to 10mA Changed V _{CAP} from 164uF to 360uF Changed Input Rise and Fall Times from 5ns to 3ns Updated I _{CC1} , I _{CC3} , I _{SB} and I _{OZ} Test conditions Changed t _{DELAY} to 20ns, 25ns, 25ns for 15ns, 20ns, 45ns part respectively Changed t _{STORE} from 15ms to 8ms Added V _{HDIS} , t _{HHD} and t _{LZHSB} parameters Software controlled STORE/RECALL cycle table: Changed t _{AS} to t _{SA} Changed t _{GHAX} to t _{HA} Added t _{DHSB} parameter Changed t _{HLHX} to t _{PHSB} Updated t _{SS} from 70us to 100us Added Truth table for SRAM operations Updated ordering information
*C	2712462	GVCH/PYRS	05/29/2009	Moved data sheet status from Preliminary to Final Updated AutoStore operation Updated I _{SB} test condition Updated footnote 7 Referenced footnote 9 to V _{CCRIS} , t _{HHD} and t _{LZHSB} parameters Updated V _{HDIS} parameter description
*D	2746310	GVCH	07/29/2009	Page 4: Updated Hardware STORE (HSB) operation description page 5: Updated Software STORE description Updated t _{DELAY} parameter description Updated footnote 18 and added footnote 23 Referenced footnote 23 to Figure 11 and Figure 12
*E	2759948	GVCH	09/04/2009	Removed commercial temperature related specs
*F	2828257	GVCH	12/15/2009	Changed STORE cycles to QuantumTrap from 200K to 1 Million Added Contents on page 2
*G	2894560	GVCH	03/18/2010	Removed part numbers CY14B108N-ZSP20XIT and CY14B108N-ZSP20XI from ordering information table. Updated Package diagrams 51-85160 and 51-85087. Updated Sales, Solution, and Legal Information Section. Updated copyright section. Updated table of contents.
*H	2923475	GVCH/AESA	04/27/2010	Table 1 : Added more clarity on <u>HSB</u> pin operation Hardware STORE Operation : Added more clarity on <u>HSB</u> pin operation Table 2 : Added more clarity on BHE/BLE pin operation Updated <u>HSB</u> pin operation in Figure 10 Updated footnote 20

Sales, Solutions, and Legal Information

Worldwide Sales and Design Support

Cypress maintains a worldwide network of offices, solution centers, manufacturer's representatives, and distributors. To find the office closest to you, visit us at [Cypress Locations](#).

Products

Automotive	cypress.com/go/automotive
Clocks & Buffers	cypress.com/go/clocks
Interface	cypress.com/go/interface
Lighting & Power Control	cypress.com/go/powerpsoc cypress.com/go/plc
Memory	cypress.com/go/memory
Optical & Image Sensing	cypress.com/go/image
PSoC	cypress.com/go/psoc
Touch Sensing	cypress.com/go/touch
USB Controllers	cypress.com/go/USB
Wireless/RF	cypress.com/go/wireless

PSoC Solutions

psoc.cypress.com/solutions
PSoC 1 | PSoC 3 | PSoC 5

© Cypress Semiconductor Corporation, 2009-2010. The information contained herein is subject to change without notice. Cypress Semiconductor Corporation assumes no responsibility for the use of any circuitry other than circuitry embodied in a Cypress product. Nor does it convey or imply any license under patent or other rights. Cypress products are not warranted nor intended to be used for medical, life support, life saving, critical control or safety applications, unless pursuant to an express written agreement with Cypress. Furthermore, Cypress does not authorize its products for use as critical components in life-support systems where a malfunction or failure may reasonably be expected to result in significant injury to the user. The inclusion of Cypress products in life-support systems application implies that the manufacturer assumes all risk of such use and in doing so indemnifies Cypress against all charges.

Any Source Code (software and/or firmware) is owned by Cypress Semiconductor Corporation (Cypress) and is protected by and subject to worldwide patent protection (United States and foreign), United States copyright laws and international treaty provisions. Cypress hereby grants to licensee a personal, non-exclusive, non-transferable license to copy, use, modify, create derivative works of, and compile the Cypress Source Code and derivative works for the sole purpose of creating custom software and or firmware in support of licensee product to be used only in conjunction with a Cypress integrated circuit as specified in the applicable agreement. Any reproduction, modification, translation, compilation, or representation of this Source Code except as specified above is prohibited without the express written permission of Cypress.

Disclaimer: CYPRESS MAKES NO WARRANTY OF ANY KIND, EXPRESS OR IMPLIED, WITH REGARD TO THIS MATERIAL, INCLUDING, BUT NOT LIMITED TO, THE IMPLIED WARRANTIES OF MERCHANTABILITY AND FITNESS FOR A PARTICULAR PURPOSE. Cypress reserves the right to make changes without further notice to the materials described herein. Cypress does not assume any liability arising out of the application or use of any product or circuit described herein. Cypress does not authorize its products for use as critical components in life-support systems where a malfunction or failure may reasonably be expected to result in significant injury to the user. The inclusion of Cypress' product in a life-support systems application implies that the manufacturer assumes all risk of such use and in doing so indemnifies Cypress against all charges.

Use may be limited by and subject to the applicable Cypress software license agreement.