

Dual Monolithic CMOS 12-Bit Multiplying DIGITAL-TO-ANALOG CONVERTERS

FEATURES

- TWO DACs IN A 0.3" WIDE PACKAGE
- SINGLE +5V SUPPLY
- HIGH-SPEED DIGITAL INTERFACE:
Serial—DAC7800
8 + 4-Bit Parallel—DAC7801
12-Bit Parallel—DAC7802
- MONOTONIC OVER TEMPERATURE
- LOW CROSSTALK: -94dB min
- FULLY SPECIFIED OVER -40°C TO $+85^{\circ}\text{C}$

DESCRIPTION

The DAC7800, DAC7801 and DAC7802 are members of a new family of monolithic dual 12-bit CMOS multiplying Digital-to-Analog Converters (DACs). The digital interface speed and the AC multiplying performance are achieved by using an advanced CMOS process optimized for data conversion circuits. High stability on-chip resistors provide true 12-bit integral and differential linearity over the wide industrial temperature range of -40°C to $+85^{\circ}\text{C}$.

The DAC7800 features a serial interface capable of clocking-in data at a rate of at least 10MHz. Serial data is clocked (edge triggered) MSB first into a 24-bit shift register and then latched into each DAC separately or simultaneously as required by the application. An asynchronous CLEAR control is provided for power-on reset or system calibration functions. It is packaged in a 16-pin 0.3" wide plastic DIP.

The DAC7801 has a 2-byte (8 + 4) double-buffered interface. Data is first loaded (level transferred) into the input registers in two steps for each DAC. Then both DACs are updated simultaneously. The DAC7801 features an asynchronous CLEAR control. The DAC7801 is packaged in a 24-pin 0.3"

APPLICATIONS

- PROCESS CONTROL OUTPUTS
- ATE PIN ELECTRONICS LEVEL SETTING
- PROGRAMMABLE FILTERS
- PROGRAMMABLE GAIN CIRCUITS
- AUTO-CALIBRATION CIRCUITS

wide plastic DIP. The DAC7802 has a single-buffered 12-bit data word interface. Parallel data is loaded (edge triggered) into the single DAC register for each DAC. The DAC7802 is packaged in a 24-pin 0.3" wide plastic DIP.

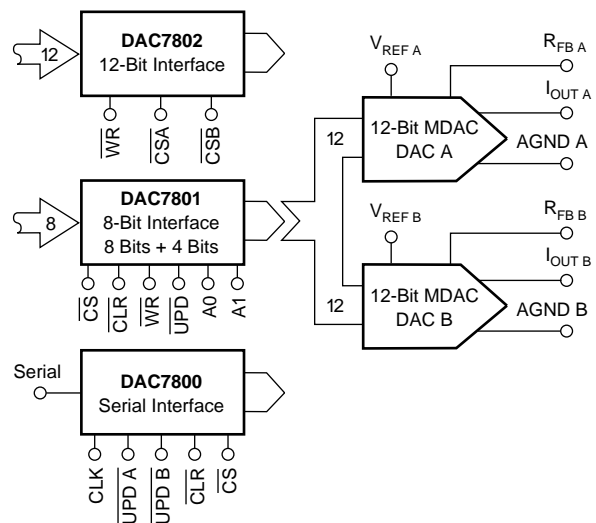

Please be aware that an important notice concerning availability, standard warranty, and use in critical applications of Texas Instruments semiconductor products and disclaimers thereto appears at the end of this data sheet.

All trademarks are the property of their respective owners.

ABSOLUTE MAXIMUM RATINGS⁽¹⁾

At $T_A = +25^\circ\text{C}$, unless otherwise noted.

V_{DD} to AGND	0V, +7V
V_{DD} to DGND	0V, +7V
AGND to DGND	-0.3, V_{DD}
Digital Input to DGND	-0.3, $V_{DD} + 0.3$
$V_{REF A}$, $V_{REF B}$ to AGND	$\pm 16\text{V}$
$V_{REF A}$, $V_{REF B}$ to DGND	$\pm 16\text{V}$
$I_{OUT A}$, $I_{OUT B}$ to AGND	-0.3, V_{DD}
Storage Temperature Range	-55°C to $+125^\circ\text{C}$
Operating Temperature Range	-40°C to $+85^\circ\text{C}$
Lead Temperature (soldering, 10s)	$+300^\circ\text{C}$
Junction Temperature	$+175^\circ\text{C}$

NOTE: (1) Stresses above those listed under "Absolute Maximum Ratings" may cause permanent damage to the device. Exposure to absolute maximum conditions for extended periods may affect device reliability.



ELECTROSTATIC DISCHARGE SENSITIVITY

This integrated circuit can be damaged by ESD. Texas Instruments recommends that all integrated circuits be handled with appropriate precautions. Failure to observe proper handling and installation procedures can cause damage.

ESD damage can range from subtle performance degradation to complete device failure. Precision integrated circuits may be more susceptible to damage because very small parametric changes could cause the device not to meet its published specifications.

PACKAGE/ORDERING INFORMATION

PRODUCT	RELATIVE ACCURACY	GAIN ERROR	PACKAGE-LEAD	PACKAGE DESIGNATOR ⁽¹⁾	SPECIFIED TEMPERATURE RANGE	PACKAGE MARKING	ORDERING NUMBER	TRANSPORT MEDIA, QUANTITY
DAC7800KP	$\pm 1\text{LSB}$	$\pm 3\text{LSB}$	DIP-16	N	-40°C to $+85^\circ\text{C}$	DAC7800KP	DAC7800KP	Rails, 25
DAC7800LP	$\pm 1/2\text{ LSB}$	$\pm 1\text{LSB}$	DIP-16	N		DAC7800LP	DAC7800LP	Rails, 25
DAC7800KU	—	—	SO-16	DW	-40°C to $+85^\circ\text{C}$	DAC7800KU	DAC7800KU/1K	Tape and Reel, 1000
DAC7800LU	—	—	SO-16	DW		DAC7800LU	DAC7800LU/1K	Tape and Reel, 1000
DAC7801KP	$\pm 1\text{LSB}$	$\pm 3\text{LSB}$	DIP-24	NTG	-40°C to $+85^\circ\text{C}$	DAC7801KP	DAC7801KP	Rails, 15
DAC7801LP	$\pm 1/2\text{ LSB}$	$\pm 1\text{LSB}$	DIP-24	NTG		DAC7801LP	DAC7801LP	Rails, 15
DAC7801KU	—	—	SO-24	DW	-40°C to $+85^\circ\text{C}$	DAC7801KU	DAC7801KU/1K	Tape and Reel, 1000
DAC7801LU	—	—	SO-24	DW		DAC7801LU	DAC7801LU/1K	Tape and Reel, 1000
DAC7802KP	$\pm 1\text{LSB}$	$\pm 3\text{LSB}$	DIP-24	NTG	-40°C to $+85^\circ\text{C}$	DAC7802KP	DAC7802KP	Rails, 15
DAC7802LP	$\pm 1/2\text{ LSB}$	$\pm 1\text{LSB}$	DIP-24	NTG		DAC7802LP	DAC7802LP	Rails, 15
DAC7802KU	—	—	SO-24	DW	-40°C to $+85^\circ\text{C}$	DAC7802KU	DAC7802KU/1K	Tape and Reel, 1000
DAC7802LU	—	—	SO-24	DW		DAC7802LU	DAC7802LU/1K	Tape and Reel, 1000

NOTE: (1) For the most current specifications and package information, see the package option addendum located at the end of this data sheet.

ELECTRICAL CHARACTERISTICS

At $V_{DD} = +5\text{VDC}$, $V_{REF A} = V_{REF B} = +10\text{V}$, $T_A = -40^\circ\text{C}$ to $+85^\circ\text{C}$, unless otherwise noted.

PARAMETER	CONDITIONS	DAC7800, 7801, 7802K			DAC7800, 7801, 7802L			UNITS
		MIN	TYP	MAX	MIN	TYP	MAX	
ACCURACY								
Resolution	Measured Using $R_{FB A}$ and $R_{FB B}$. All Registers Loaded with All 1s.	12			*			Bits
Relative Accuracy				± 1			$\pm 1/2$	LSB
Differential Nonlinearity				± 1			*	LSB
Gain Error				± 3			± 1	LSB
Gain Temperature Coefficient ⁽¹⁾	$T_A = +25^\circ\text{C}$ $T_A = -40^\circ\text{C}$ to $+85^\circ\text{C}$		2	5		*	*	ppm/ $^\circ\text{C}$
Output Leakage Current			0.005	10		*	*	nA
			3	150		*	*	nA
REFERENCE INPUT								
Input Resistance		6	10	14	*	*	*	k Ω
Input Resistance Match			0.5	3		*	2	%
DIGITAL INPUTS								
V_{IH} (Input HIGH Voltage)	$T_A = +25^\circ\text{C}$ $T_A = -40^\circ\text{C}$ to $+85^\circ\text{C}$	2			*			V
V_{IL} (Input LOW Voltage)				0.8			*	V
I_{IN} (Input Current)				± 1			*	μA
				± 10			*	μA
C_{IN} (Input Capacitance)			0.8	10		*	*	pF
POWER SUPPLY								
V_{DD}	V_{DD} from 4.5V to 5.5V	4.5		5.5	*		*	V
I_{DD}			0.2	2		*	*	mA
Power-Supply Rejection				0.002			*	%/%

* Same specification as for DAC7800, 7801, 7802K.

AC PERFORMANCE

OUTPUT OP AMP IS OPA602.

At $V_{DD} = +5VDC$, $V_{REF A} = V_{REF B} = +10V$, $T_A = +25^{\circ}C$, unless otherwise noted. These specifications are fully characterized but not subject to test.

PARAMETER	CONDITIONS	DAC7800, 7801, 7802K			DAC7800, 7801, 7802L			UNITS
		MIN	TYP	MAX	MIN	TYP	MAX	
OUTPUT CURRENT SETTLING TIME	To 0.01% of Full-Scale $R_L = 100\Omega$, $C_L = 13pF$		0.4	0.8		*	*	μs
DIGITAL-TO-ANALOG GLITCH IMPULSE	$V_{REF A} = V_{REF B} = 0V$ $R_L = 100\Omega$, $C_L = 13pF$		0.9			*		nV-s
AC FEEDTHROUGH	$f_{VREF} = 10kHz$		-75	-72		*	*	dB
OUTPUT CAPACITANCE	DAC Loaded with All 0s DAC Loaded with All 1s		30 70	50 100		*	*	pF pF
CHANNEL-TO-CHANNEL ISOLATION $V_{REF A}$ to $I_{OUT B}$	$f_{VREF A} = 10kHz$ $V_{REF B} = 0V$, Both DACs Loaded with 1s	-90	-94		*	*		dB
$V_{REF B}$ to $I_{OUT A}$	$f_{VREF B} = 10kHz$ $V_{REF A} = 0V$, Both DACs Loaded with 1s	-90	-101		*	*		dB
DIGITAL CROSSTALK	Full-Scale Transition $R_L = 100\Omega$, $C_L = 13pF$		0.9			*		nV-s

* Same specification as for DAC7800, 7801, and 7802K.

NOTE: (1) Ensured but not tested.

DAC7800

BLOCK DIAGRAM

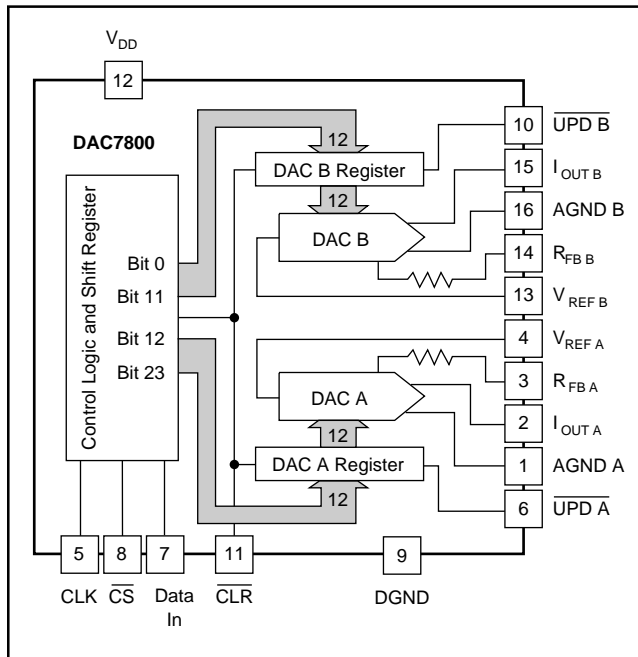

PIN CONFIGURATION

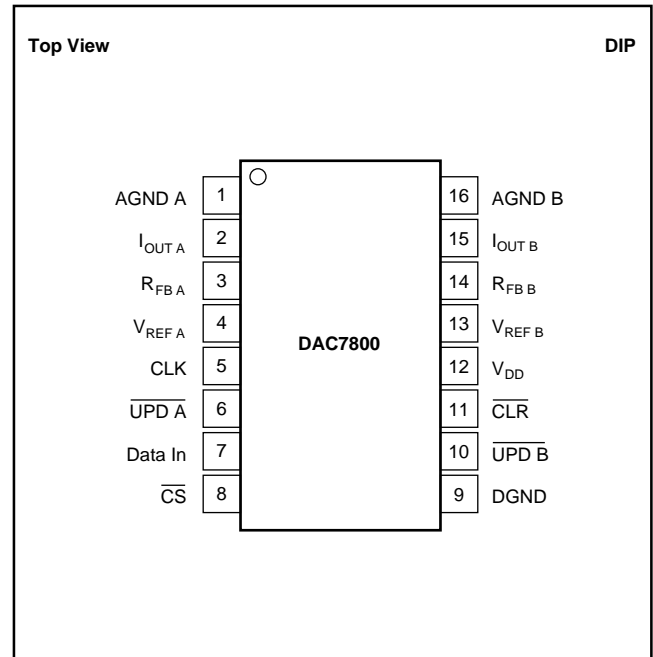

LOGIC TRUTH TABLE

CLK	UPD A	UPD B	CS	CLR	FUNCTION
X	X	X	X	0	All register contents set to 0's (asynchronous).
X	X	X	1	X	No data transfer.
$\overline{1}$	X	X	0	1	Input data is clocked into input register (location Bit 23) and previous data shifts.
X	0	1	0	1	Input register bits 23 (LSB) - 12 (MSB) are loaded into DAC A.
X	1	0	0	1	Input register bits 11 (LSB) - 0 (MSB) are loaded into DAC B.
X	0	0	0	1	Input register bits 23 (LSB) - 12 (MSB) are loaded into DAC A, and input register bits 11 (LSB) - 0 (MSB) are loaded into DAC B.

X = Don't care. $\overline{1}$ means falling edge triggered.

DAC7800 (Cont.)

DATA INPUT FORMAT

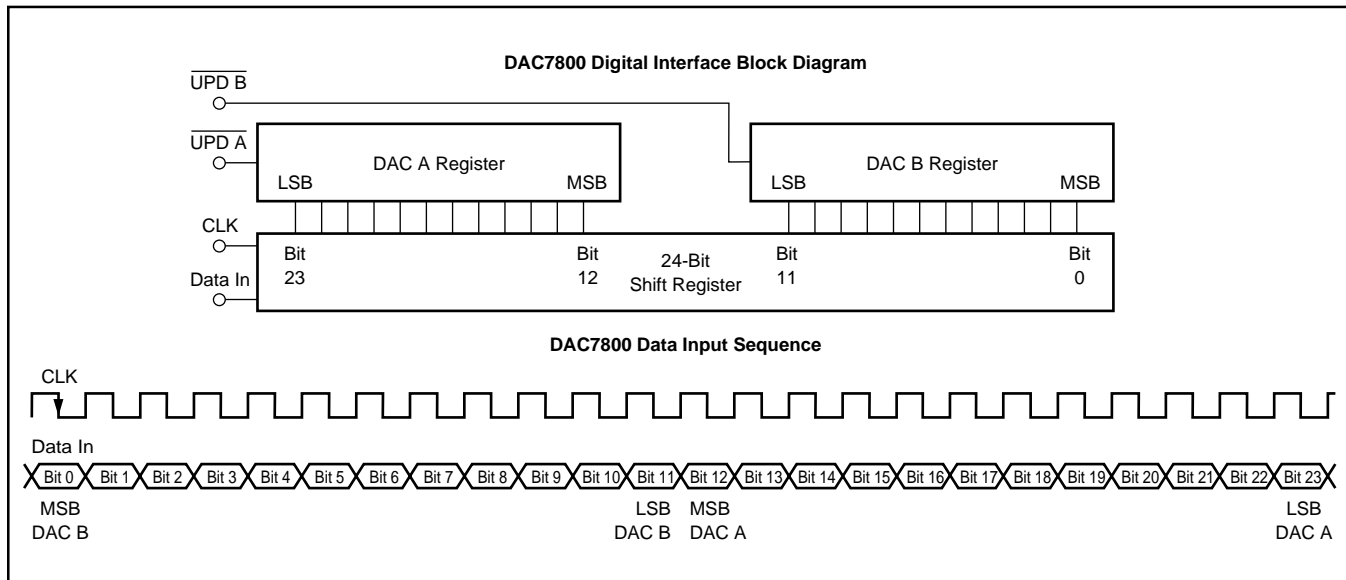

TIMING CHARACTERISTICS

$V_{DD} = +5V$, $V_{REF A} = V_{REF B} = +10V$, $T_A = -40^{\circ}C$ to $+85^{\circ}C$.

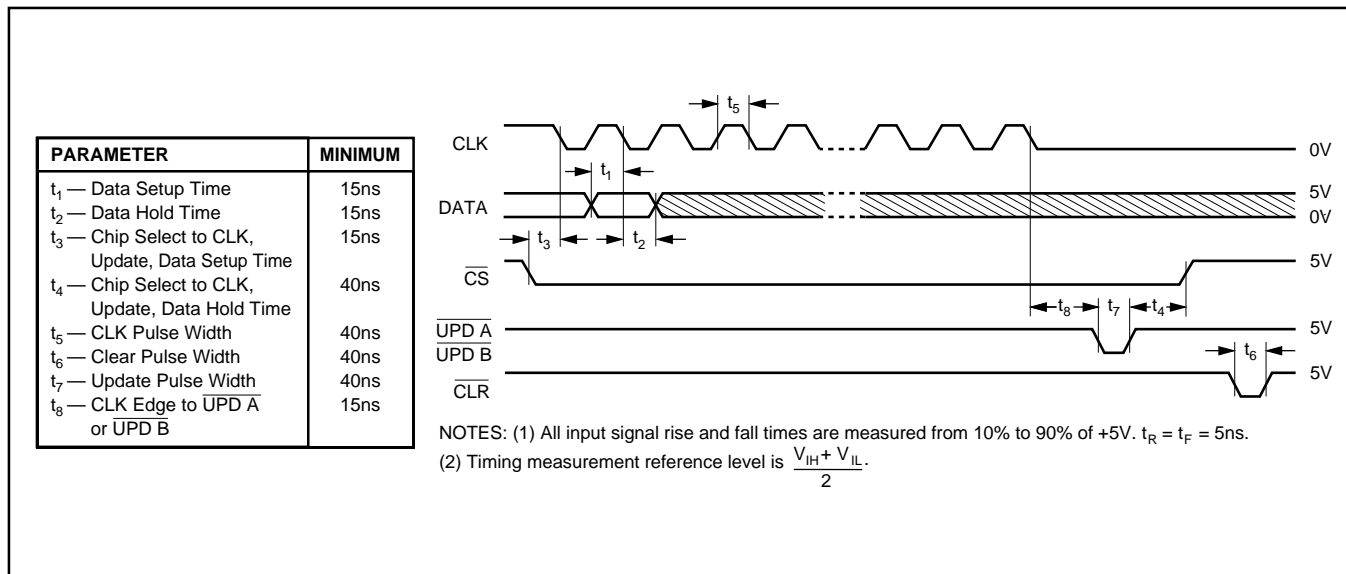

DAC7801

BLOCK DIAGRAM

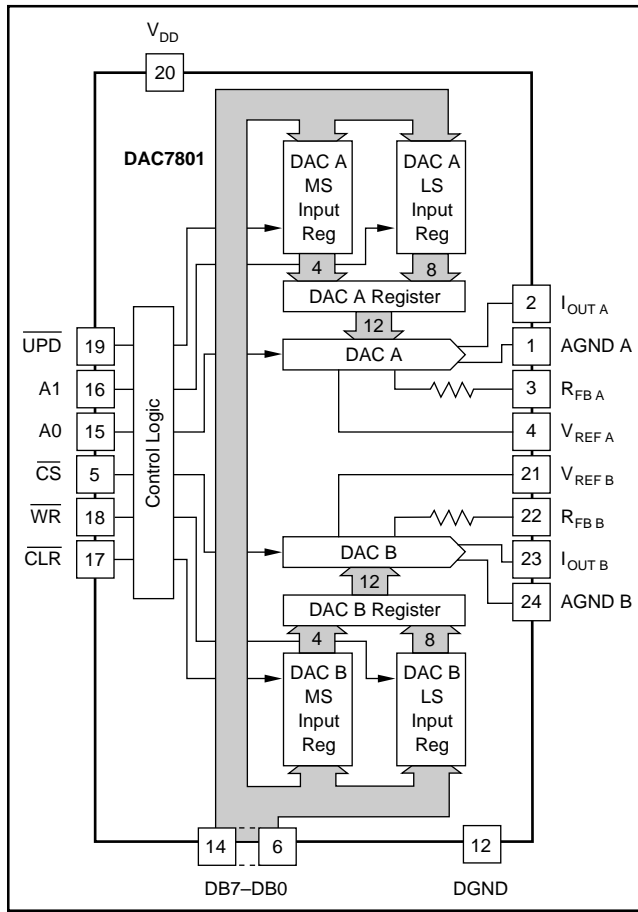

PIN CONFIGURATION

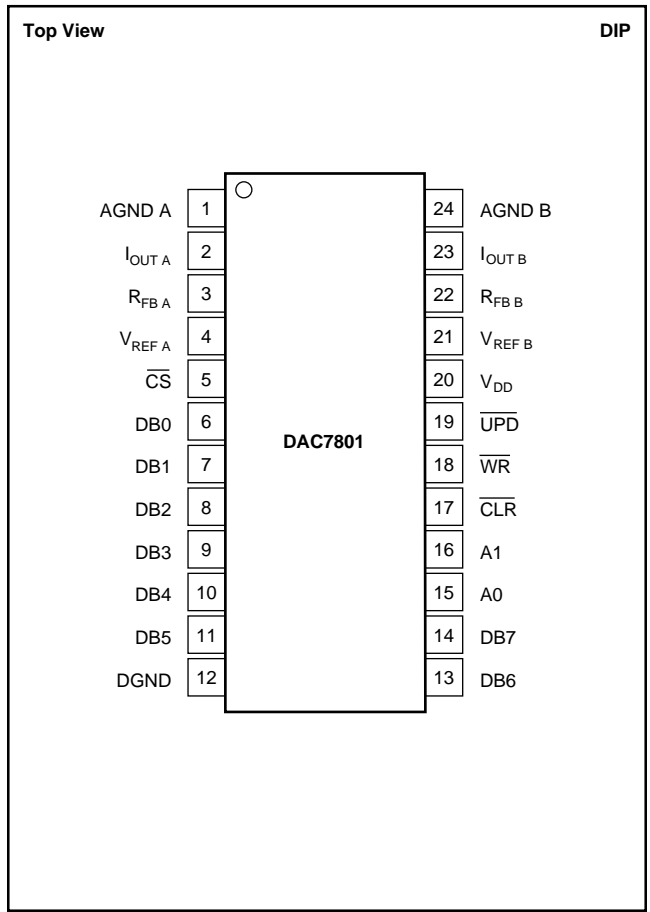

LOGIC TRUTH TABLE

\overline{CLR}	\overline{UPD}	\overline{CS}	\overline{WR}	A1	A0	FUNCTION
1	1	1	X	X	X	No Data Transfer
1	1	X	1	X	X	No Data Transfer
0	X	X	X	X	X	All Registers Cleared
1	1	0	0	0	0	DAC A LS Input Register Loaded with DB7 - DB0 (LSB)
1	1	0	0	0	1	DAC A MS Input Register Loaded with DB3 (MSB) - DB0
1	1	0	0	1	0	DAC B LS Input Register Loaded with DB7 - DB0 (LSB)
1	1	0	0	1	1	DAC B MS Input Register Loaded with DB3 (MSB) - DB0
1	0	1	0	X	X	DAC A, DAC B Registers Updated Simultaneously from Input Registers
1	0	0	0	X	X	DAC A, DAC B Registers are Transparent

X = Don't care.

TIMING CHARACTERISTICS

V_{DD} = +5V, V_{REF A} = V_{REF B} = +10V, T_A = -40°C to +85°C.

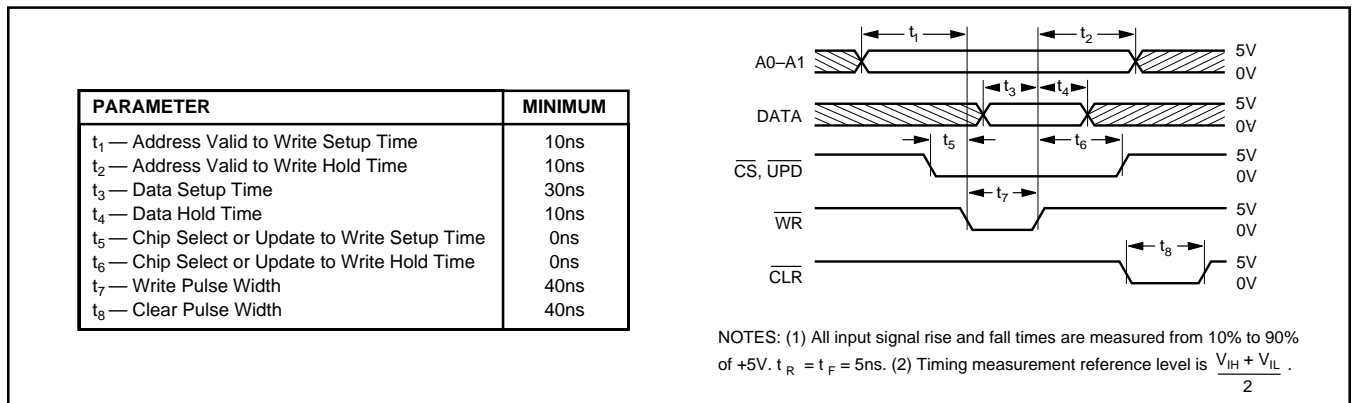

DAC7802

BLOCK DIAGRAM

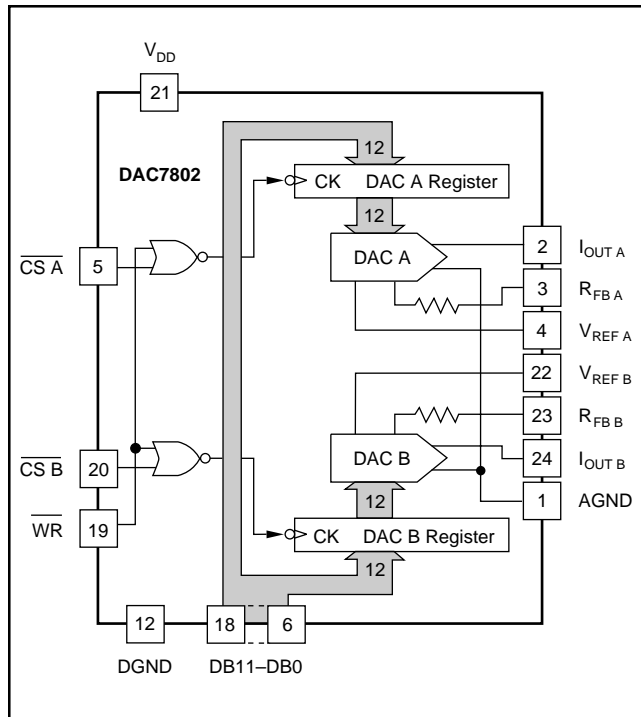

PIN CONFIGURATION

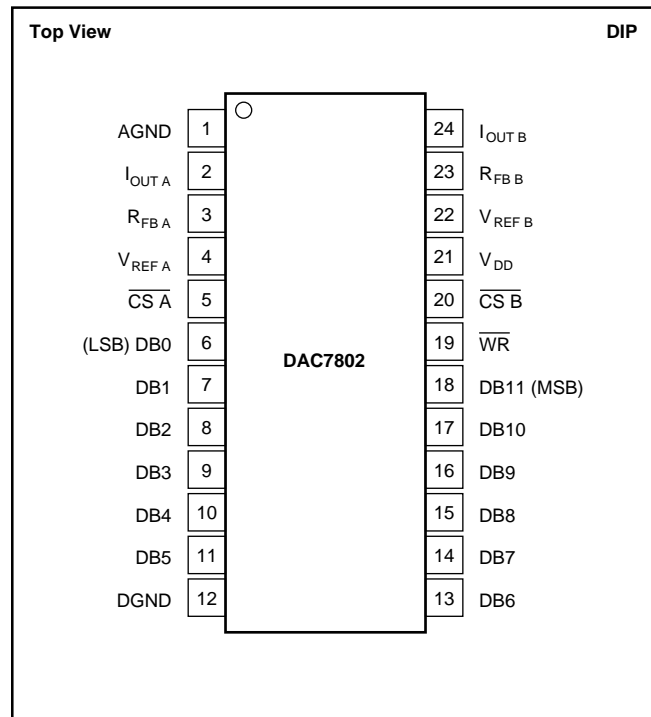

TIMING CHARACTERISTICS

At $V_{DD} = +5V$, and $T_A = -40^\circ C$ to $+85^\circ C$.

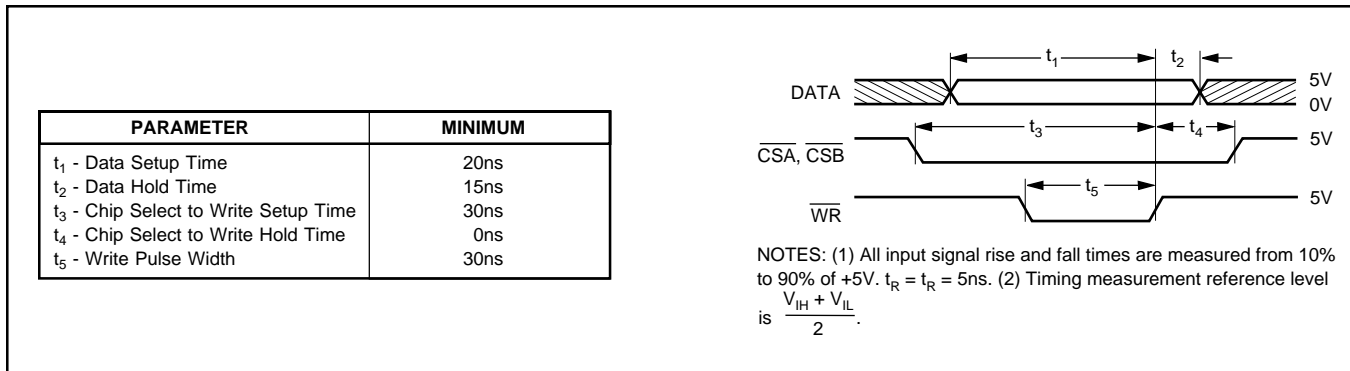

LOGIC TRUTH TABLE

CSA	CSB	WR	FUNCTION
X	X	1	No Data Transfer
1	1	X	No Data Transfer
\uparrow	\uparrow	0	A Rising Edge on \overline{CSA} or \overline{CSB} Loads Data to the Respective DAC
0	1	\uparrow	DAC A Register Loaded from Data Bus
1	0	\uparrow	DAC B Register Loaded from Data Bus
0	0	\uparrow	DAC A and DAC B Registers Loaded from Data Bus

X = Don't care. \uparrow means rising edge triggered.

TYPICAL CHARACTERISTICS

OUTPUT OP AMP IS OPA602.

$T_A = +25^\circ\text{C}$, $V_{DD} = +5\text{V}$.

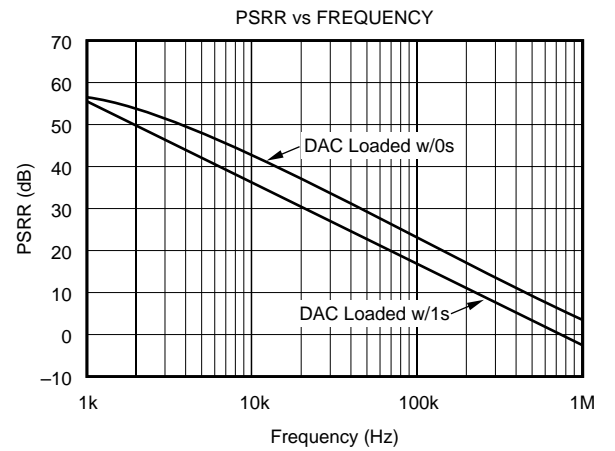
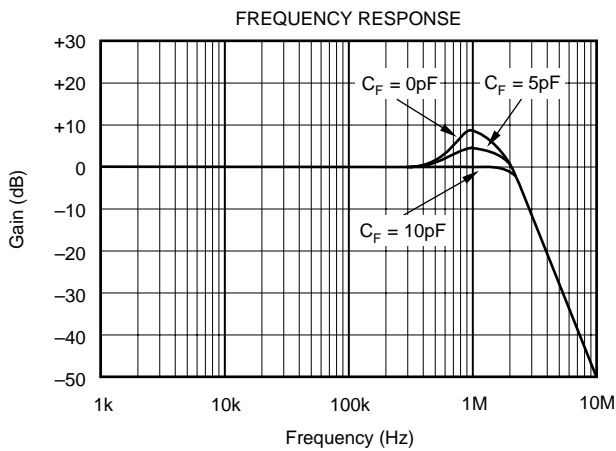
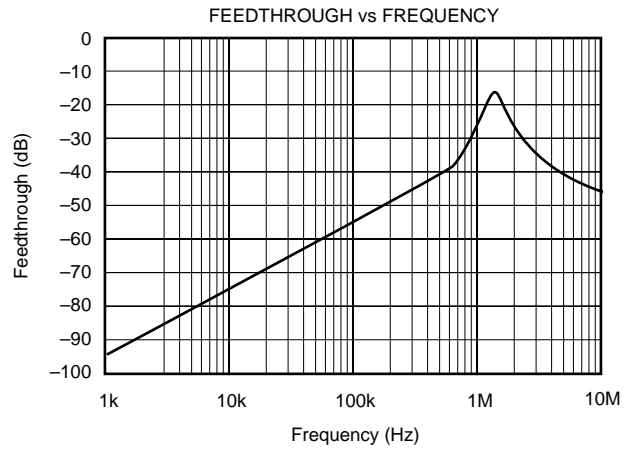
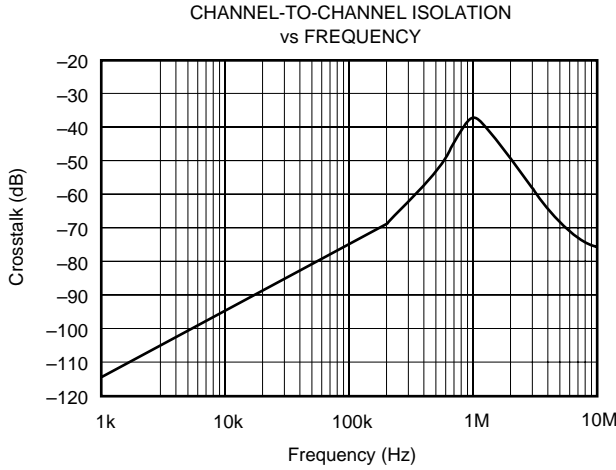
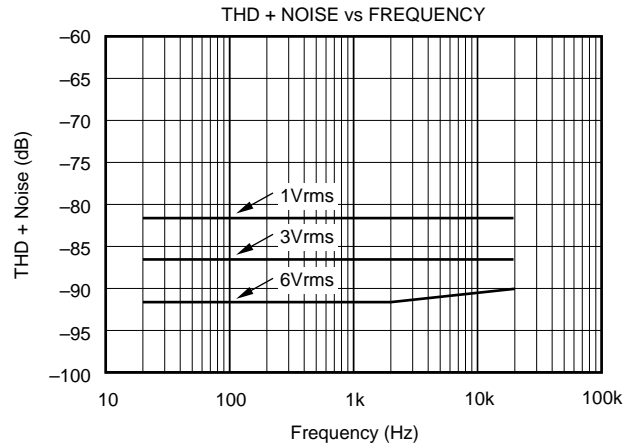
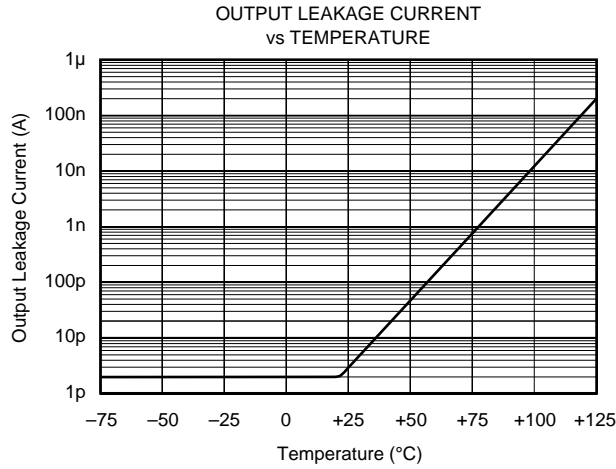

DISCUSSION OF SPECIFICATIONS

RELATIVE ACCURACY

This term, also known as end point linearity or integral linearity, describes the transfer function of analog output to digital input code. Relative accuracy describes the deviation from a straight line, after zero and full-scale errors have been adjusted to zero.

DIFFERENTIAL NONLINEARITY

Differential nonlinearity is the deviation from an ideal 1LSB change in the output when the input code changes by 1LSB. A differential nonlinearity specification of 1LSB maximum ensures monotonicity.

GAIN ERROR

Gain error is the difference between the full-scale DAC output and the ideal value. The ideal full scale output value for the DAC780x is $-(4095/4096)V_{REF}$. Gain error may be adjusted to zero using external trims, see Figures 5 and 7.

OUTPUT LEAKAGE CURRENT

The current which appears at $I_{OUT A}$ and $I_{OUT B}$ with the DAC loaded with all zeros.

OUTPUT CAPACITANCE

The parasitic capacitance measured from $I_{OUT A}$ or $I_{OUT B}$ to AGND.

CHANNEL-TO-CHANNEL ISOLATION

The AC output error due to capacitive coupling from DAC A to DAC B or DAC B to DAC A.

MULTIPLYING FEEDTHROUGH ERROR

The AC output error due to capacitive coupling from V_{REF} to I_{OUT} with the DAC loaded with all zeros.

OUTPUT CURRENT SETTling TIME

The time required for the output current to settle to within $\pm 0.01\%$ of final value for a full-scale step.

DIGITAL-TO-ANALOG GLITCH ENERGY

The integrated area of the glitch pulse measured in nanovolt-seconds. The key contributor to DAC glitch is charge injected by digital logic switching transients.

DIGITAL CROSSTALK

Glitch impulse measured at the output of one DAC but caused by a full-scale transition on the other DAC. The integrated area of the glitch pulse is measured in nanovolt-seconds.

CIRCUIT DESCRIPTION

Figure 1 shows a simplified schematic of one half of a DAC780x. The current from the $V_{REF A}$ pin is switched between $I_{OUT A}$ and AGND by 12 single-pole double-throw CMOS switches. This maintains a constant current in each leg of the ladder regardless of the input code. The input resistance at V_{REF} is therefore

constant and can be driven by either a voltage or current, AC or DC, positive or negative polarity, and have a voltage range up to $\pm 20V$.

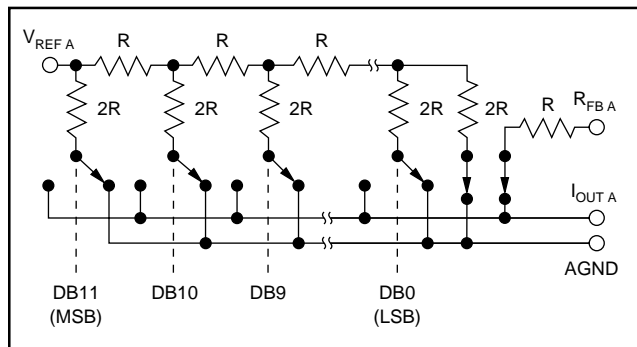

FIGURE 1. Simplified Circuit Diagram for DAC A.

A CMOS switch transistor, included in series with the ladder terminating resistor and in series with the feedback resistor, $R_{FB A}$, compensates for the temperature drift of the ON resistance of the ladder switches.

Figure 2 shows an equivalent circuit for DAC A. C_{OUT} is the output capacitance due to the N-channel switches and varies from about 30pF to 70pF with digital input code. The current source I_{LKG} is the combination of surface and junction leakages to the substrate. I_{LKG} approximately doubles every $10^{\circ}C$. R_O is the equivalent output resistance of the DAC and it varies with input code.

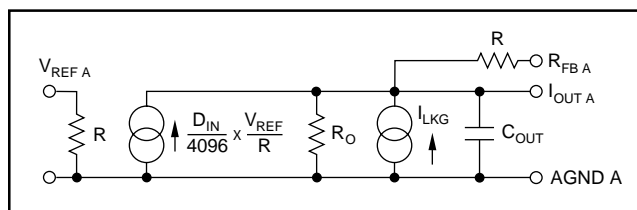

FIGURE 2. Equivalent Circuit for DAC A.

INSTALLATION

ESD PROTECTION

All digital inputs of the DAC780x incorporate on-chip ESD protection circuitry. This protection is designed to withstand 2.5kV (using the Human Body Model, 100pF and 1500Ω). However, industry standard ESD protection methods should be used when handling or storing these components. When not in use, devices should be stored in conductive foam or rails. The foam or rails should be discharged to the destination socket potential before devices are removed.

POWER-SUPPLY CONNECTIONS

The DAC780x are designed to operate on $V_{DD} = +5V \pm 10\%$. For optimum performance and noise rejection, power-supply decoupling capacitors C_D should be added as shown in the application circuits. These capacitors (1μF tantalum recommended) should be located close to the DAC. AGND and

DGND should be connected together at one point only, preferably at the power-supply ground point. Separate returns minimize current flow in low-level signal paths if properly connected. Output op amp analog common (+ input) should be connected as near to the AGND pins of the DAC780x as possible.

WIRING PRECAUTIONS

To minimize AC feedthrough when designing a PC board, care should be taken to minimize capacitive coupling between the V_{REF} lines and the I_{OUT} lines. Similarly, capacitive coupling between DACs may compromise the channel-to-channel isolation. Coupling from any of the digital control or data lines might degrade the glitch and digital crosstalk performance. Solder the DAC780x directly into the PC board without a socket. Sockets add parasitic capacitance (which can degrade AC performance).

AMPLIFIER OFFSET VOLTAGE

The output amplifier used with the DAC780x should have low input offset voltage to preserve the transfer function linearity. The voltage output of the amplifier has an error component which is the offset voltage of the op amp multiplied by the “noise gain” of the circuit. This “noise gain” is equal to $(R_F/R_O + 1)$ where R_O is the output impedance of the DAC I_{OUT} terminal and R_F is the feedback network impedance. The nonlinearity occurs due to the output impedance varying with code. If the 0 code case is excluded (where $R_O = \infty$), the R_O will vary from $R/3R$ providing a “noise gain” variation between $4/3$ and 2 . In addition, the variation of R_O is nonlinear with code, and the largest steps in R_O occur at major code transitions where the worst differential nonlinearity is also likely to be experienced. The nonlinearity seen at the amplifier output is $2V_{OS} - 4V_{OS}/3 = 2V_{OS}/3$. Thus, to maintain good nonlinearity the op amp offset should be much less than $1/2$ LSB.

UNIPOLAR CONFIGURATION

Figure 3 shows DAC780x in a typical unipolar (two-quadrant) multiplying configuration. The analog output values versus digital input code are listed in Table II. The operational amplifiers used in this circuit can be single amplifiers such as the OPA602, or a dual amplifier such as the OPA2107. C1 and C2 provide phase compensation to minimize settling time and overshoot when using a high speed operational amplifier. If an application requires the DAC to have zero gain error, the circuit shown in Figure 4 may be used. Resistors R_2 and R_4 induce a positive gain error greater than worst-case initial negative gain error. Trim resistors R_1 and R_3 provide a variable negative gain error and have sufficient trim range to correct for the worst-case initial positive gain error plus the error produced by R_2 and R_4 .

BIPOLAR CONFIGURATION

See Figure 5 for the DAC780x in a typical bipolar (four-quadrant) multiplying configuration. See Table III for the listing of the analog output values versus digital input code.

DATA INPUT		ANALOG OUTPUT
MSB ↓	↓ LSB	$-V_{REF}$ (4095/4096)
1111 1111 1111		$-V_{REF}$ (2048/4096) = $-1/2V_{REF}$
1000 0000 0000		$-V_{REF}$ (1/4096)
0000 0000 0001		0 Volts
0000 0000 0000		

TABLE II. Unipolar Output Code.

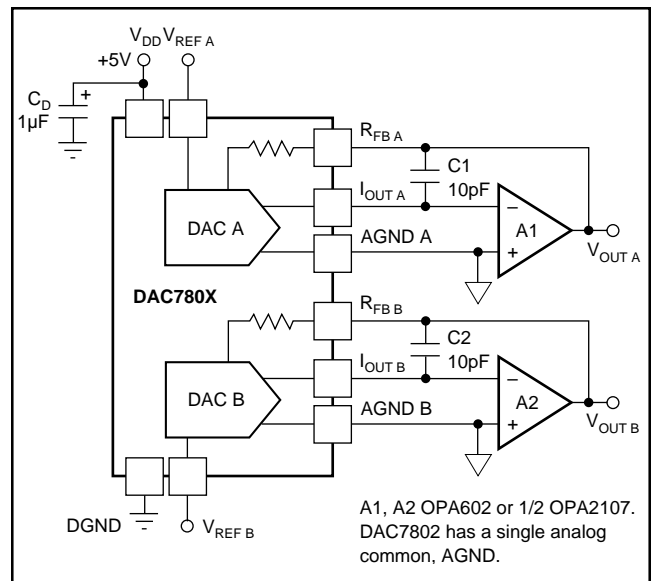

FIGURE 3. Unipolar Configuration.

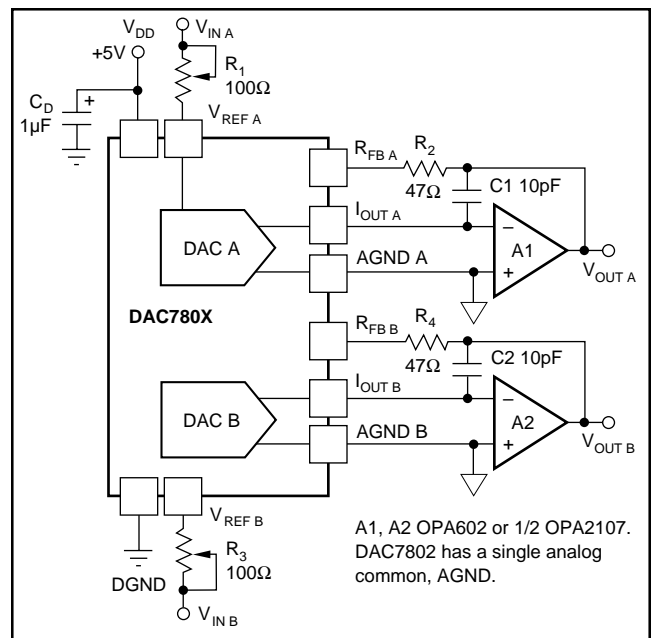

FIGURE 4. Unipolar Configuration with Gain Trim.

The operational amplifiers used in this circuit can be single amplifiers such as the OPA602, a dual amplifier such as the OPA2107, or a quad amplifier like the OPA404. C1 and C2 provide phase compensation to minimize settling time and overshoot when using a high speed operational amplifier. The bipolar offset resistors R_5 – R_7 and R_8 – R_{10} should be ratio-matched to 0.01% to ensure the specified gain error performance.

If an application requires the DAC to have zero gain error, the circuit may be used, see Figure 6. Resistors R_2 and R_4 induce a positive gain error greater than worst-case initial negative gain error. Trim resistors R_1 and R_3 provide a variable negative gain error and have sufficient trim range to correct for the worst-case initial positive gain error plus the error produced by R_2 and R_4 .

DATA INPUT		ANALOG OUTPUT	
MSB ↓	↓ LSB	$+V_{REF}$ (2047/2048)	
1111 1111 1111		$+V_{REF}$ (1/2048)	
1000 0000 0001		0 Volts	
1000 0000 0000		$-V_{REF}$ (1/2048)	
0111 1111 1111		$-V_{REF}$ (2048/2048)	
0000 0000 0000			

TABLE III. Bipolar Output Code.

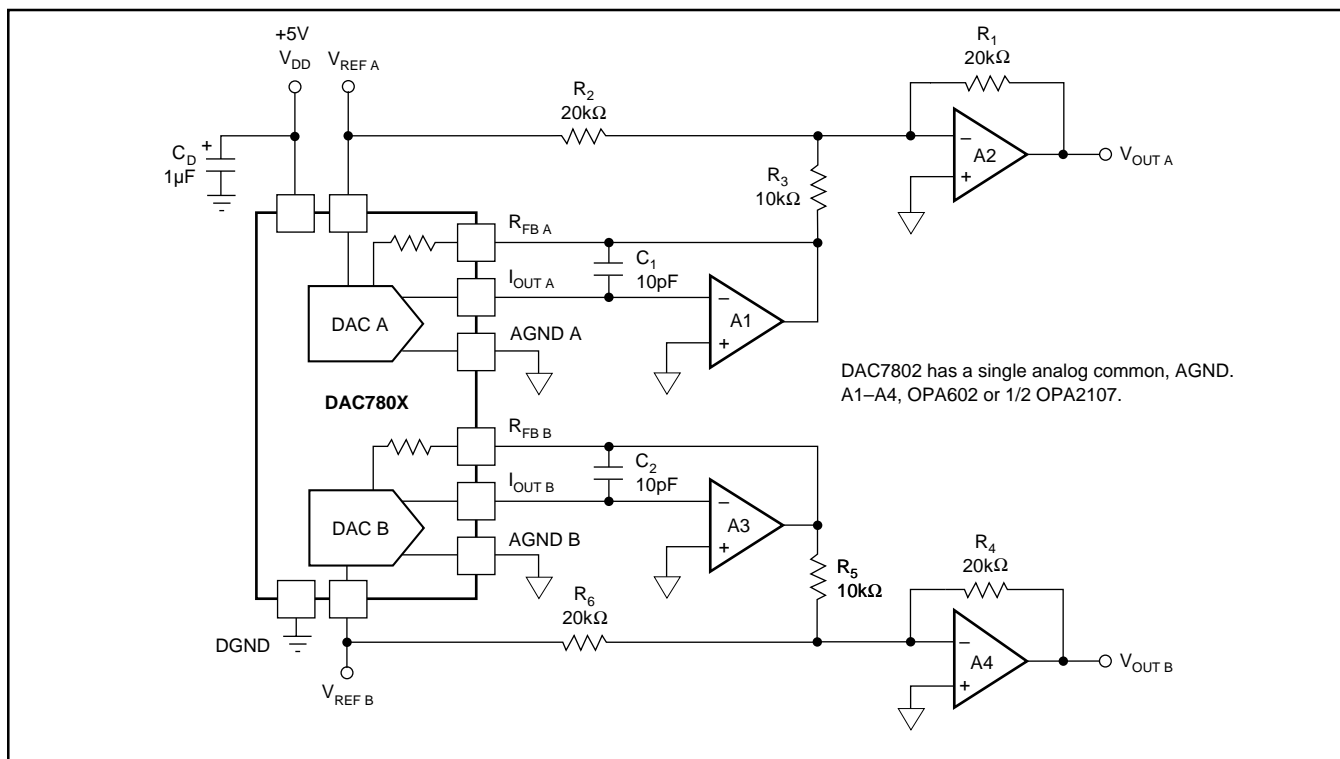

FIGURE 5. Bipolar Configuration.

APPLICATIONS

12-BIT PLUS SIGN DACS

For a bipolar DAC with 13 bits of resolution, two solutions are possible. The addition of a precision difference amplifier and a high speed JFET switch provides a 12-bit plus sign voltage-output DAC, see Figure 7. When the switch selects the op amp output, the difference amplifier serves as a noninverting output buffer. If the analog ground side of the switch is selected, the output of the difference amplifier is inverted.

Another option, see Figure 8, also produces a 12-bit plus sign output without the additional switch and digital control line.

DIGITALLY PROGRAMMABLE ACTIVE FILTER

See Figure 9 for the DAC780x in a digitally programmable active filter application. The design is based on the state-variable filter, Texas Instruments UAF42, an active filter topology that offers stable and repeatable filter characteristics.

DAC1 and DAC2 can be updated in parallel with a single word to set the center frequency of the filter. DAC 4, which makes use of the uncommitted op amp in UAF42, sets the Q of the filter. DAC3 sets the gain of the filter transfer function without changing the Q of the filter. The reverse is also true.

The center frequency is determined by $f_c = 1/2\pi RC$ where R is the ladder resistance of the DAC (typical value, 10kΩ) and C the internal capacitor value (1000pF) of the UAF42. External capacitors can be added to lower the center frequency of the filter. But the highest center frequency for this circuit will be about 16kHz because the effective series resistance of the DAC cannot be less than 10kΩ.

Note that the ladder resistance of the DAC may vary from device to device. Thus, for best tracking, DAC2 and DAC3 should be in the same package. Some calibration may be necessary from one filter to another.

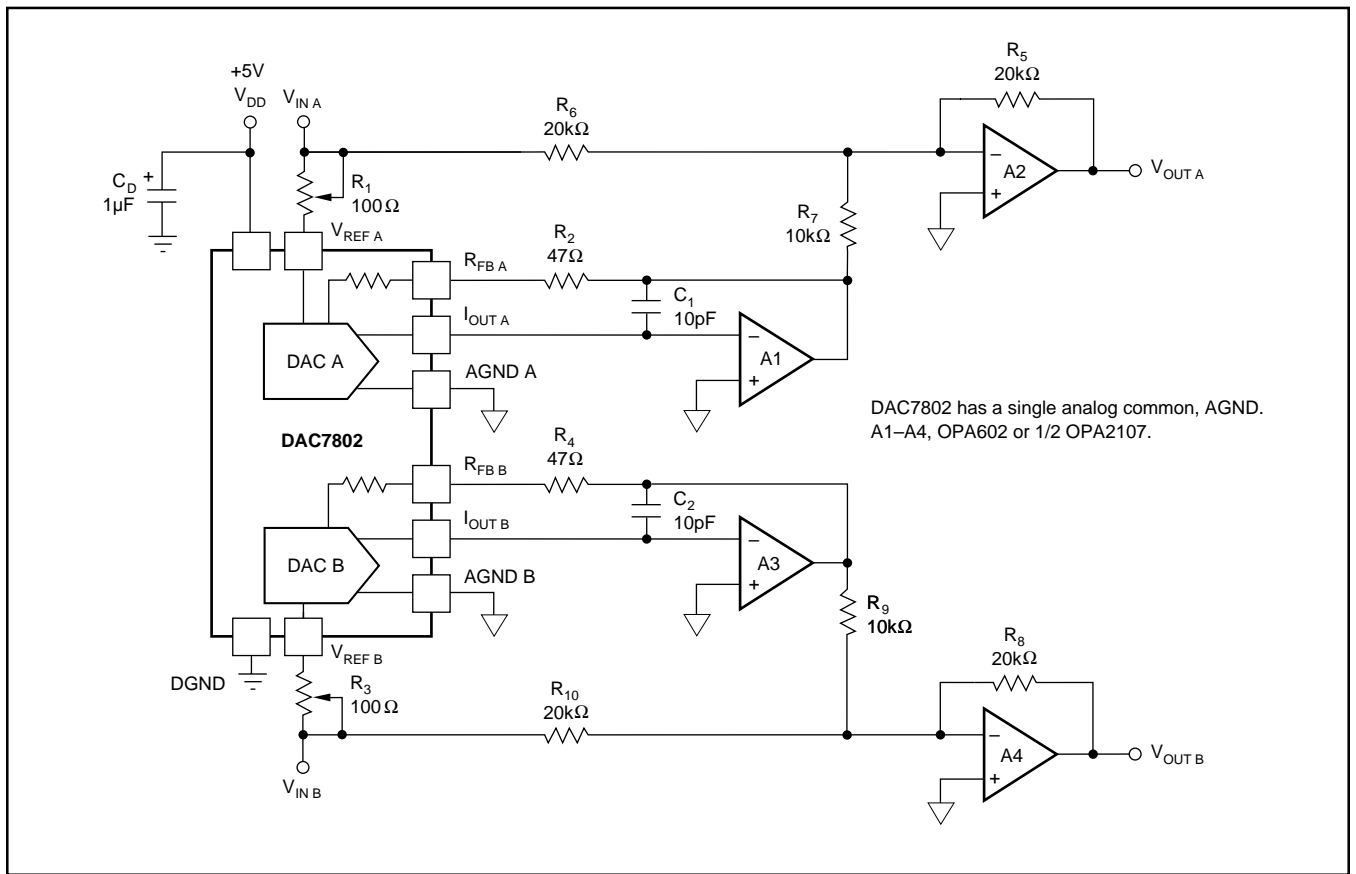

FIGURE 6. Bipolar Configuration with Gain Trim.

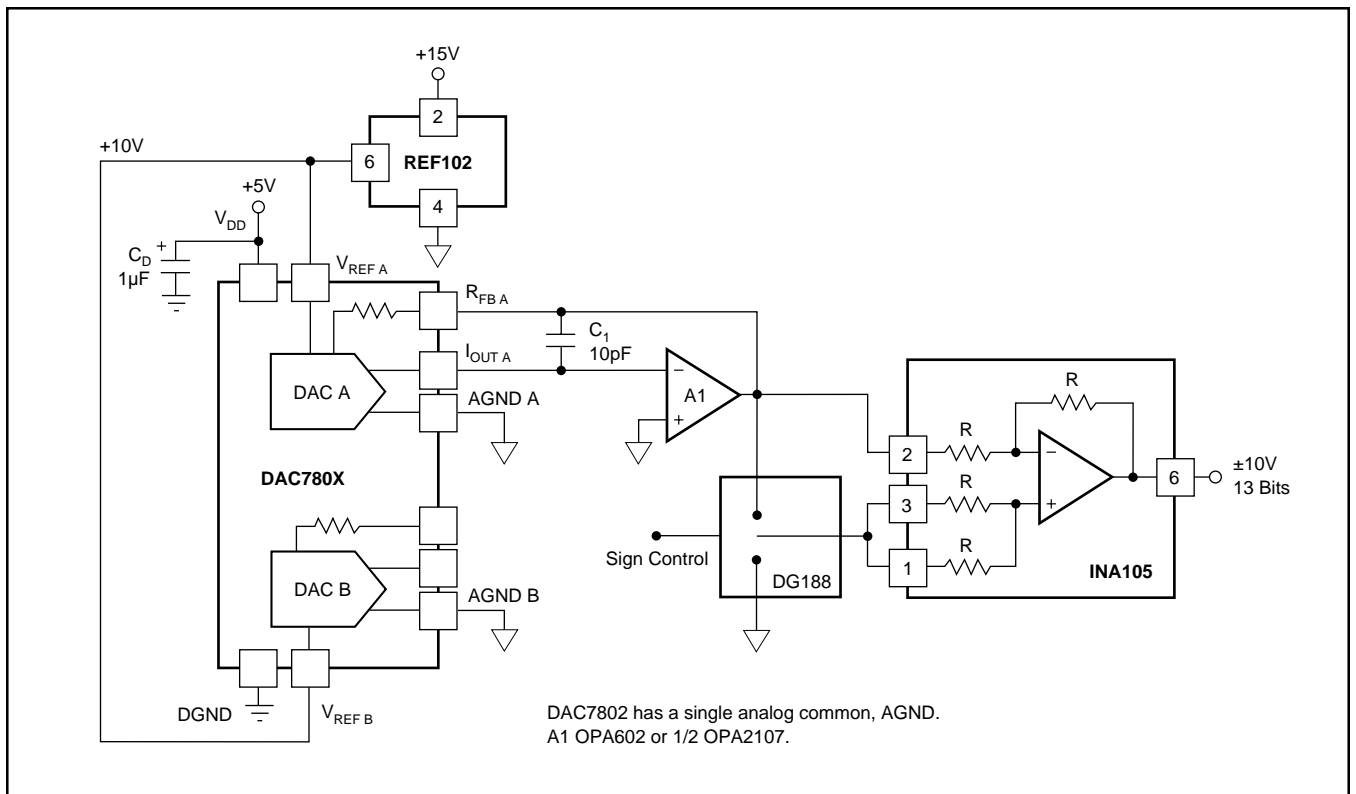

FIGURE 7. 12-Bit Plus Sign DAC.

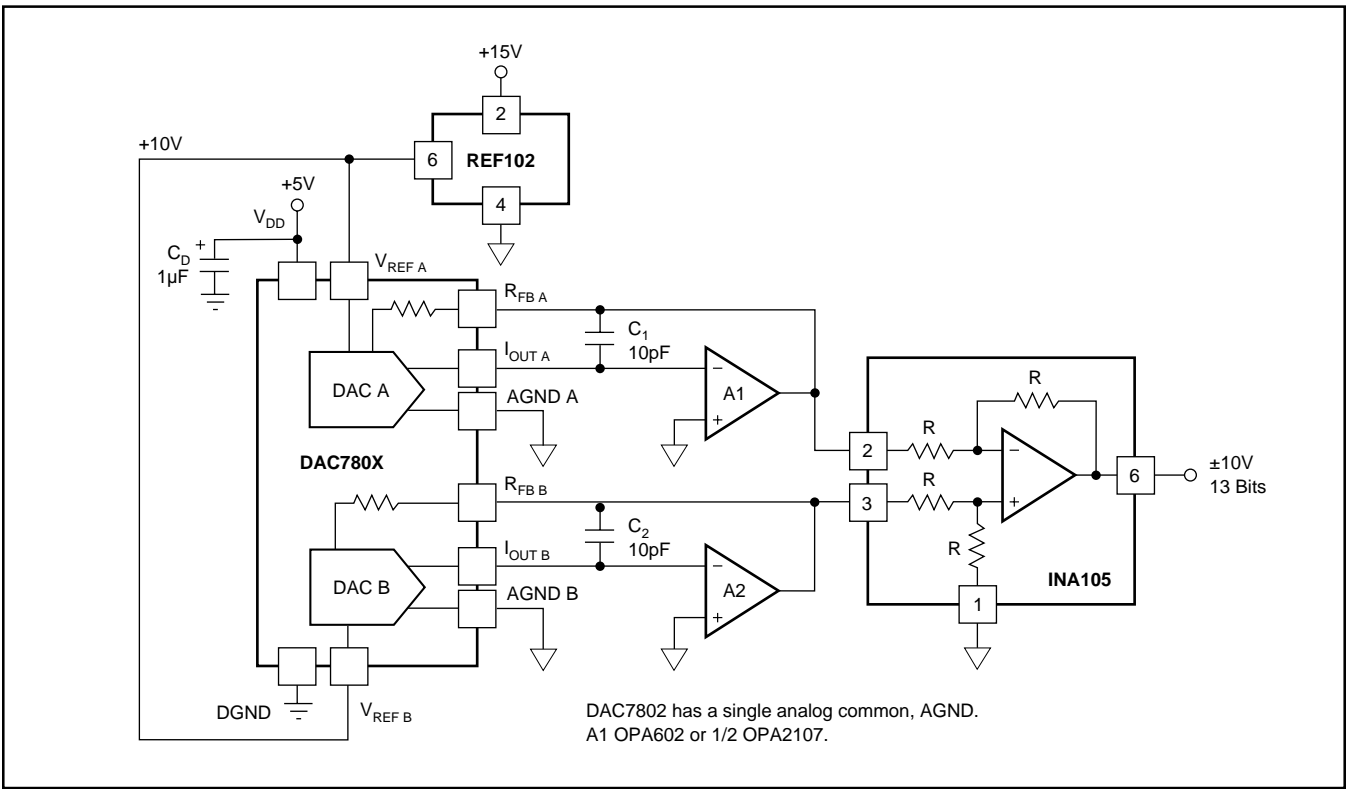

FIGURE 8. 13-Bit Bipolar DAC.

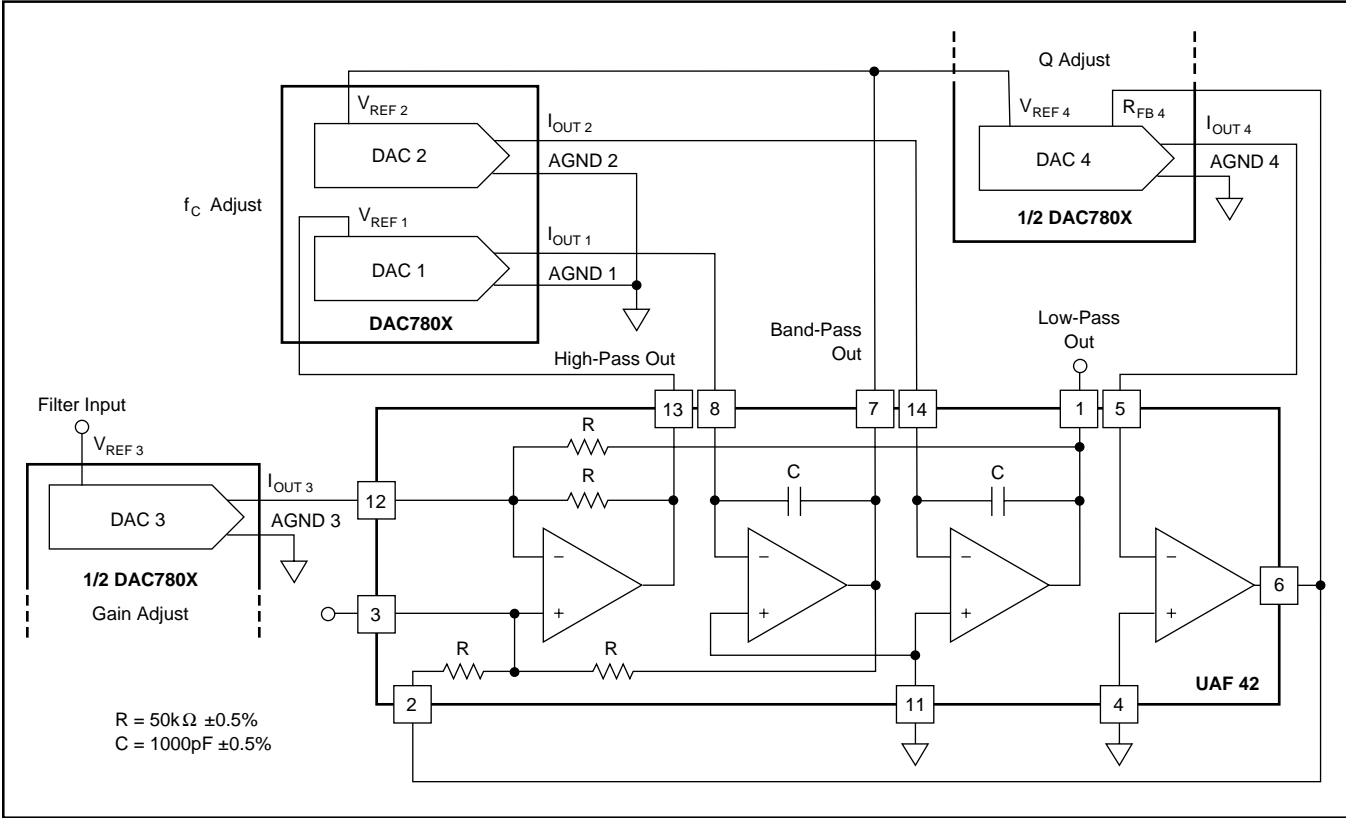

FIGURE 9. Digitally Programmable Universal Active Filter.

PACKAGING INFORMATION

Orderable Device	Status ⁽¹⁾	Package Type	Package Drawing	Pins	Package Qty	Eco Plan ⁽²⁾	Lead/ Ball Finish	MSL Peak Temp ⁽³⁾	Samples (Requires Login)
DAC7800KP	NRND	PDIP	N	16	25	Green (RoHS & no Sb/Br)	CU NIPDAU	N / A for Pkg Type	Replaced by DAC7800KU
DAC7800KPG4	NRND	PDIP	N	16	25	Green (RoHS & no Sb/Br)	CU NIPDAU	N / A for Pkg Type	Samples Not Available
DAC7800KU	ACTIVE	SOIC	DW	16	40	Green (RoHS & no Sb/Br)	CU NIPDAU	Level-3-260C-168 HR	Purchase Samples
DAC7800KU/1K	ACTIVE	SOIC	DW	16	1000	Green (RoHS & no Sb/Br)	CU NIPDAU	Level-3-260C-168 HR	Purchase Samples
DAC7800KU/1KG4	ACTIVE	SOIC	DW	16	1000	Green (RoHS & no Sb/Br)	CU NIPDAU	Level-3-260C-168 HR	Purchase Samples
DAC7800KUG4	ACTIVE	SOIC	DW	16	40	Green (RoHS & no Sb/Br)	CU NIPDAU	Level-3-260C-168 HR	Purchase Samples
DAC7800LP	NRND	PDIP	N	16	25	Green (RoHS & no Sb/Br)	CU NIPDAU	N / A for Pkg Type	Replaced by DAC7800KU
DAC7800LPG4	NRND	PDIP	N	16	25	Green (RoHS & no Sb/Br)	CU NIPDAU	N / A for Pkg Type	Replaced by DAC7800KUG4
DAC7800LU	NRND	SOIC	DW	16	40	Green (RoHS & no Sb/Br)	CU NIPDAU	Level-3-260C-168 HR	Replaced by DAC7800KU
DAC7800LU/1K	OBSOLETE	SOIC	DW	16		TBD	Call TI	Call TI	Replaced by DAC7800KU/1K
DAC7800LUG4	NRND	SOIC	DW	16	40	Green (RoHS & no Sb/Br)	CU NIPDAU	Level-3-260C-168 HR	Replaced by DAC7800KUG4
DAC7801KP	NRND	PDIP	NT	24	15	Green (RoHS & no Sb/Br)	CU NIPDAU	N / A for Pkg Type	Replaced by DAC7801KU
DAC7801KPG4	NRND	PDIP	NT	24	15	Green (RoHS & no Sb/Br)	CU NIPDAU	N / A for Pkg Type	Samples Not Available
DAC7801KU	ACTIVE	SOIC	DW	24	25	Green (RoHS & no Sb/Br)	CU NIPDAU	Level-3-260C-168 HR	Purchase Samples
DAC7801KU/1K	ACTIVE	SOIC	DW	24	1000	Green (RoHS & no Sb/Br)	CU NIPDAU	Level-3-260C-168 HR	Purchase Samples
DAC7801KU/1KG4	ACTIVE	SOIC	DW	24	1000	Green (RoHS & no Sb/Br)	CU NIPDAU	Level-3-260C-168 HR	Purchase Samples
DAC7801KUG4	ACTIVE	SOIC	DW	24	25	Green (RoHS & no Sb/Br)	CU NIPDAU	Level-3-260C-168 HR	Purchase Samples

Orderable Device	Status ⁽¹⁾	Package Type	Package Drawing	Pins	Package Qty	Eco Plan ⁽²⁾	Lead/ Ball Finish	MSL Peak Temp ⁽³⁾	Samples (Requires Login)
DAC7801LP	NRND	PDIP	NT	24	15	Green (RoHS & no Sb/Br)	CU NIPDAU	N / A for Pkg Type	Replaced by DAC7800LU
DAC7801LPG4	NRND	PDIP	NT	24	15	Green (RoHS & no Sb/Br)	CU NIPDAU	N / A for Pkg Type	Samples Not Available
DAC7801LU	ACTIVE	SOIC	DW	24	25	Green (RoHS & no Sb/Br)	CU NIPDAU	Level-3-260C-168 HR	Request Free Samples
DAC7801LU/1K	ACTIVE	SOIC	DW	24	1000	Green (RoHS & no Sb/Br)	CU NIPDAU	Level-3-260C-168 HR	Purchase Samples
DAC7801LU/1KG4	ACTIVE	SOIC	DW	24	1000	Green (RoHS & no Sb/Br)	CU NIPDAU	Level-3-260C-168 HR	Purchase Samples
DAC7801LUG4	ACTIVE	SOIC	DW	24	25	Green (RoHS & no Sb/Br)	CU NIPDAU	Level-3-260C-168 HR	Contact TI Distributor or Sales Office
DAC7802KP	NRND	PDIP	NTG	24	15	Green (RoHS & no Sb/Br)	CU NIPDAU	N / A for Pkg Type	Replaced by DAC7802KU
DAC7802KU	ACTIVE	SOIC	DW	24	25	Green (RoHS & no Sb/Br)	CU NIPDAU	Level-3-260C-168 HR	Contact TI Distributor or Sales Office
DAC7802KU/1K	ACTIVE	SOIC	DW	24	1000	Green (RoHS & no Sb/Br)	CU NIPDAU	Level-3-260C-168 HR	Purchase Samples
DAC7802KU/1KG4	ACTIVE	SOIC	DW	24	1000	Green (RoHS & no Sb/Br)	CU NIPDAU	Level-3-260C-168 HR	Purchase Samples
DAC7802KUG4	ACTIVE	SOIC	DW	24	25	Green (RoHS & no Sb/Br)	CU NIPDAU	Level-3-260C-168 HR	Contact TI Distributor or Sales Office
DAC7802LP	NRND	PDIP	NTG	24	15	Green (RoHS & no Sb/Br)	CU NIPDAU	N / A for Pkg Type	Replaced by DAC7802LU
DAC7802LU	ACTIVE	SOIC	DW	24	25	Green (RoHS & no Sb/Br)	CU NIPDAU	Level-3-260C-168 HR	Request Free Samples
DAC7802LUG4	ACTIVE	SOIC	DW	24	25	Green (RoHS & no Sb/Br)	CU NIPDAU	Level-3-260C-168 HR	Contact TI Distributor or Sales Office

⁽¹⁾ The marketing status values are defined as follows:

ACTIVE: Product device recommended for new designs.

LIFEBUY: TI has announced that the device will be discontinued, and a lifetime-buy period is in effect.

NRND: Not recommended for new designs. Device is in production to support existing customers, but TI does not recommend using this part in a new design.

PREVIEW: Device has been announced but is not in production. Samples may or may not be available.

OBSELETE: TI has discontinued the production of the device.

⁽²⁾ Eco Plan - The planned eco-friendly classification: Pb-Free (RoHS), Pb-Free (RoHS Exempt), or Green (RoHS & no Sb/Br) - please check <http://www.ti.com/productcontent> for the latest availability information and additional product content details.

TBD: The Pb-Free/Green conversion plan has not been defined.

Pb-Free (RoHS): TI's terms "Lead-Free" or "Pb-Free" mean semiconductor products that are compatible with the current RoHS requirements for all 6 substances, including the requirement that lead not exceed 0.1% by weight in homogeneous materials. Where designed to be soldered at high temperatures, TI Pb-Free products are suitable for use in specified lead-free processes.

Pb-Free (RoHS Exempt): This component has a RoHS exemption for either 1) lead-based flip-chip solder bumps used between the die and package, or 2) lead-based die adhesive used between the die and leadframe. The component is otherwise considered Pb-Free (RoHS compatible) as defined above.

Green (RoHS & no Sb/Br): TI defines "Green" to mean Pb-Free (RoHS compatible), and free of Bromine (Br) and Antimony (Sb) based flame retardants (Br or Sb do not exceed 0.1% by weight in homogeneous material)

⁽³⁾ MSL, Peak Temp. -- The Moisture Sensitivity Level rating according to the JEDEC industry standard classifications, and peak solder temperature.

Important Information and Disclaimer: The information provided on this page represents TI's knowledge and belief as of the date that it is provided. TI bases its knowledge and belief on information provided by third parties, and makes no representation or warranty as to the accuracy of such information. Efforts are underway to better integrate information from third parties. TI has taken and continues to take reasonable steps to provide representative and accurate information but may not have conducted destructive testing or chemical analysis on incoming materials and chemicals. TI and TI suppliers consider certain information to be proprietary, and thus CAS numbers and other limited information may not be available for release.

In no event shall TI's liability arising out of such information exceed the total purchase price of the TI part(s) at issue in this document sold by TI to Customer on an annual basis.

TAPE AND REEL INFORMATION



QUADRANT ASSIGNMENTS FOR PIN 1 ORIENTATION IN TAPE



*All dimensions are nominal

Device	Package Type	Package Drawing	Pins	SPQ	Reel Diameter (mm)	Reel Width W1 (mm)	A0 (mm)	B0 (mm)	K0 (mm)	P1 (mm)	W (mm)	Pin1 Quadrant
DAC7800KU/1K	SOIC	DW	16	1000	330.0	16.4	10.85	10.8	2.7	12.0	16.0	Q1
DAC7801KU/1K	SOIC	DW	24	1000	330.0	24.4	10.85	15.8	2.7	12.0	24.0	Q1
DAC7801LU/1K	SOIC	DW	24	1000	330.0	24.4	10.85	15.8	2.7	12.0	24.0	Q1
DAC7802KU/1K	SOIC	DW	24	1000	330.0	24.4	10.85	15.8	2.7	12.0	24.0	Q1

TAPE AND REEL BOX DIMENSIONS



*All dimensions are nominal

Device	Package Type	Package Drawing	Pins	SPQ	Length (mm)	Width (mm)	Height (mm)
DAC7800KU/1K	SOIC	DW	16	1000	346.0	346.0	33.0
DAC7801KU/1K	SOIC	DW	24	1000	346.0	346.0	41.0
DAC7801LU/1K	SOIC	DW	24	1000	346.0	346.0	41.0
DAC7802KU/1K	SOIC	DW	24	1000	346.0	346.0	41.0

NTG (R-PDIP-T24)

PLASTIC DUAL-IN-LINE

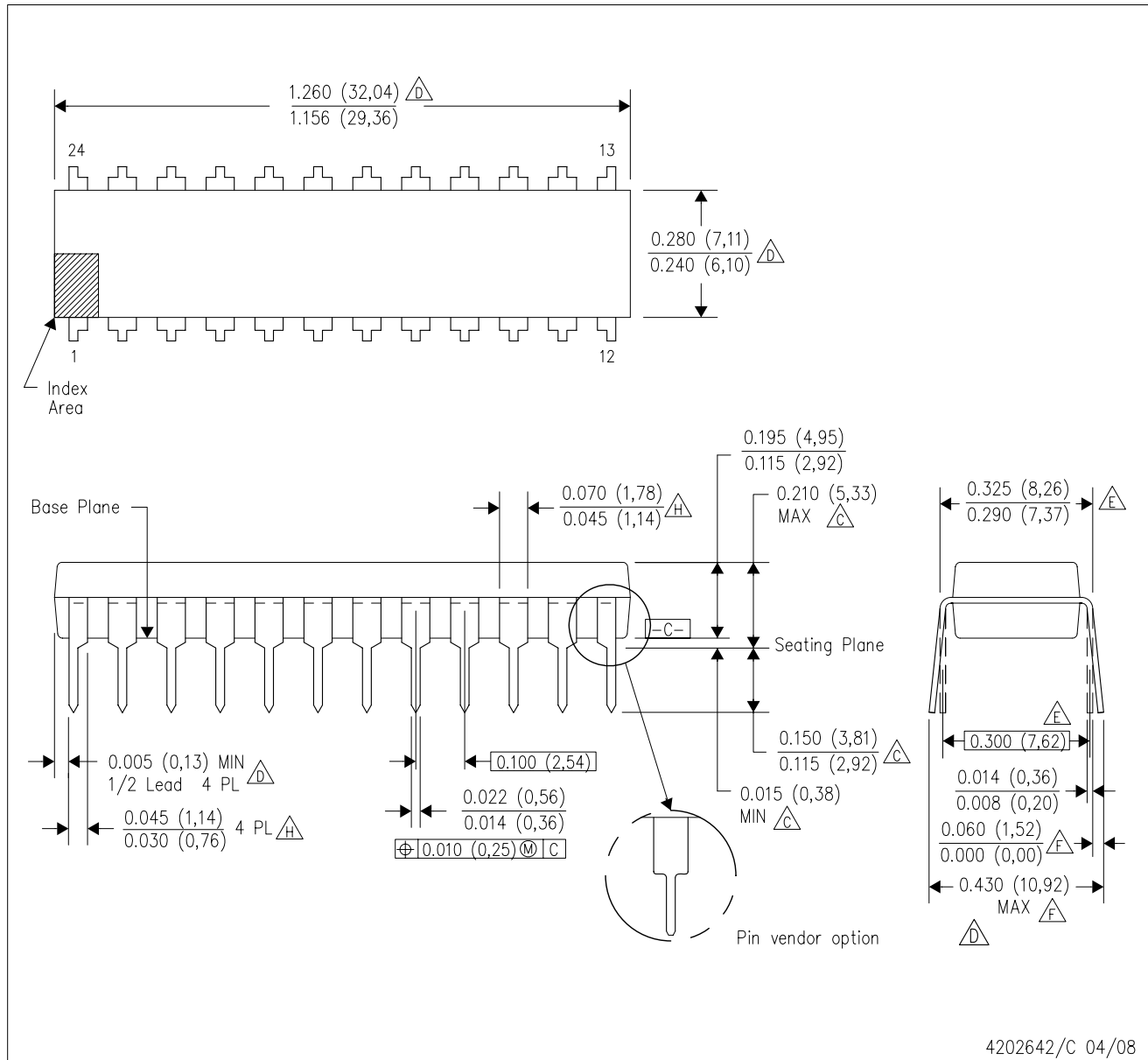

NOTES:

- A. All linear dimensions are in inches (millimeters).
- B. This drawing is subject to change without notice.
- \triangle Dimensions are measured with the package seated in JEDEC seating plane gauge GS-3.
- \triangle Dimensions do not include mold flash or protrusions. Mold flash or protrusions shall not exceed 0.010 (0,25).
- \triangle Dimensions measured with the leads constrained to be perpendicular to Datum C.
- \triangle Dimensions are measured at the lead tips with the leads unconstrained.
- G. Pointed or rounded lead tips are preferred to ease insertion.
- \triangle Maximum dimensions do not include dambar protrusions. Dambars protrusions shall not exceed 0.010 (0,25).
- I. Distance between leads including dambar protrusions to be 0.005 (0,13) minimum.
- J. A visual index feature must be located within the cross-hatched area.
- K. For automatic insertion, any raised irregularity on the top surface (step, mesa, etc.) shall be symmetrical about the lateral and longitudinal package centerlines.
- L. Controlling dimension in inches.

DW (R-PDSO-G24)

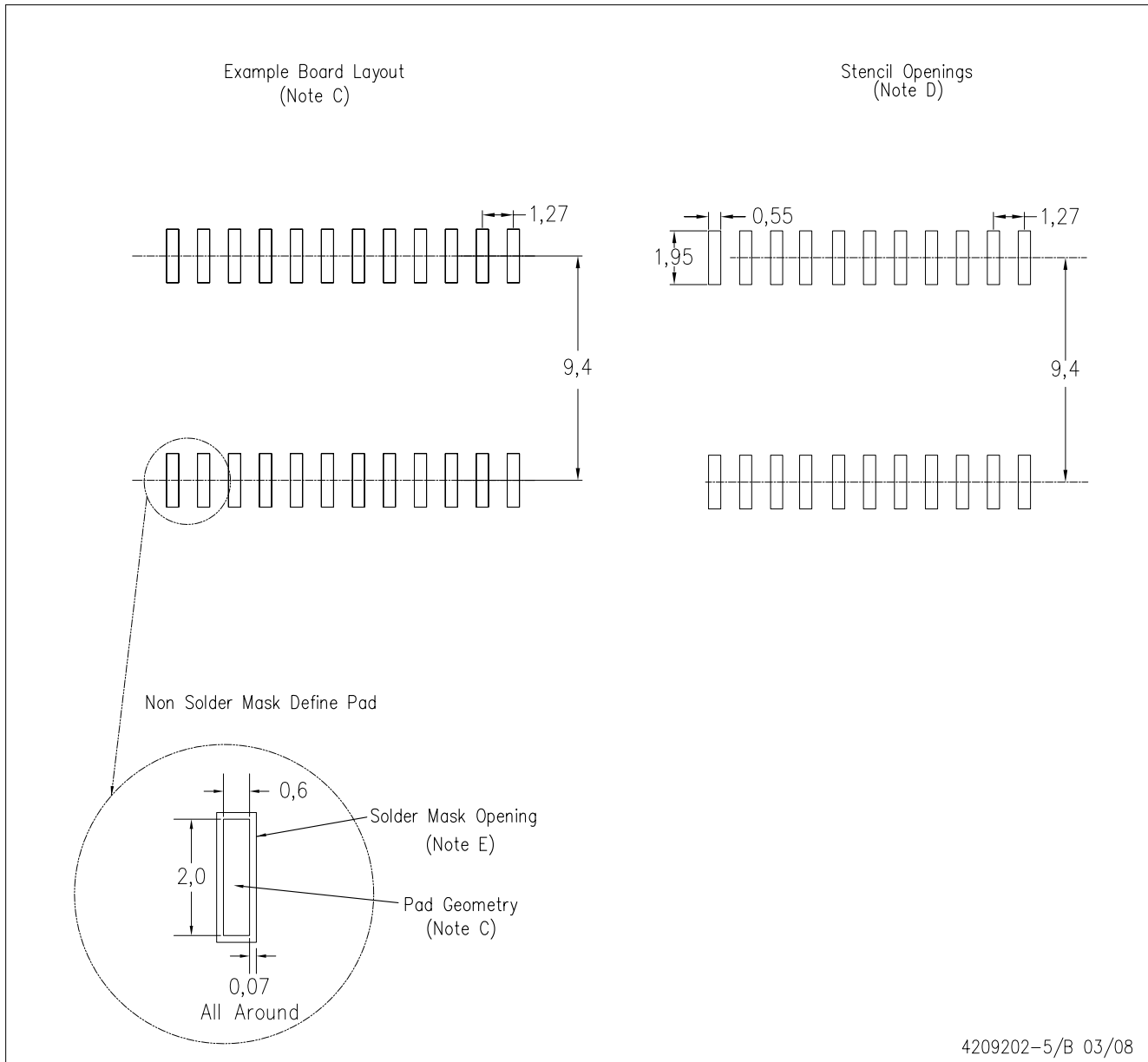

4209202-5/B 03/08

- NOTES:
- A. All linear dimensions are in millimeters.
 - B. This drawing is subject to change without notice.
 - C. Refer to IPC7351 for alternate board design.
 - D. Laser cutting apertures with trapezoidal walls and also rounding corners will offer better paste release. Customers should contact their board assembly site for stencil design recommendations. Refer to IPC-7525
 - E. Customers should contact their board fabrication site for solder mask tolerances between and around signal pads.

DW (R-PDSO-G16)

PLASTIC SMALL-OUTLINE PACKAGE

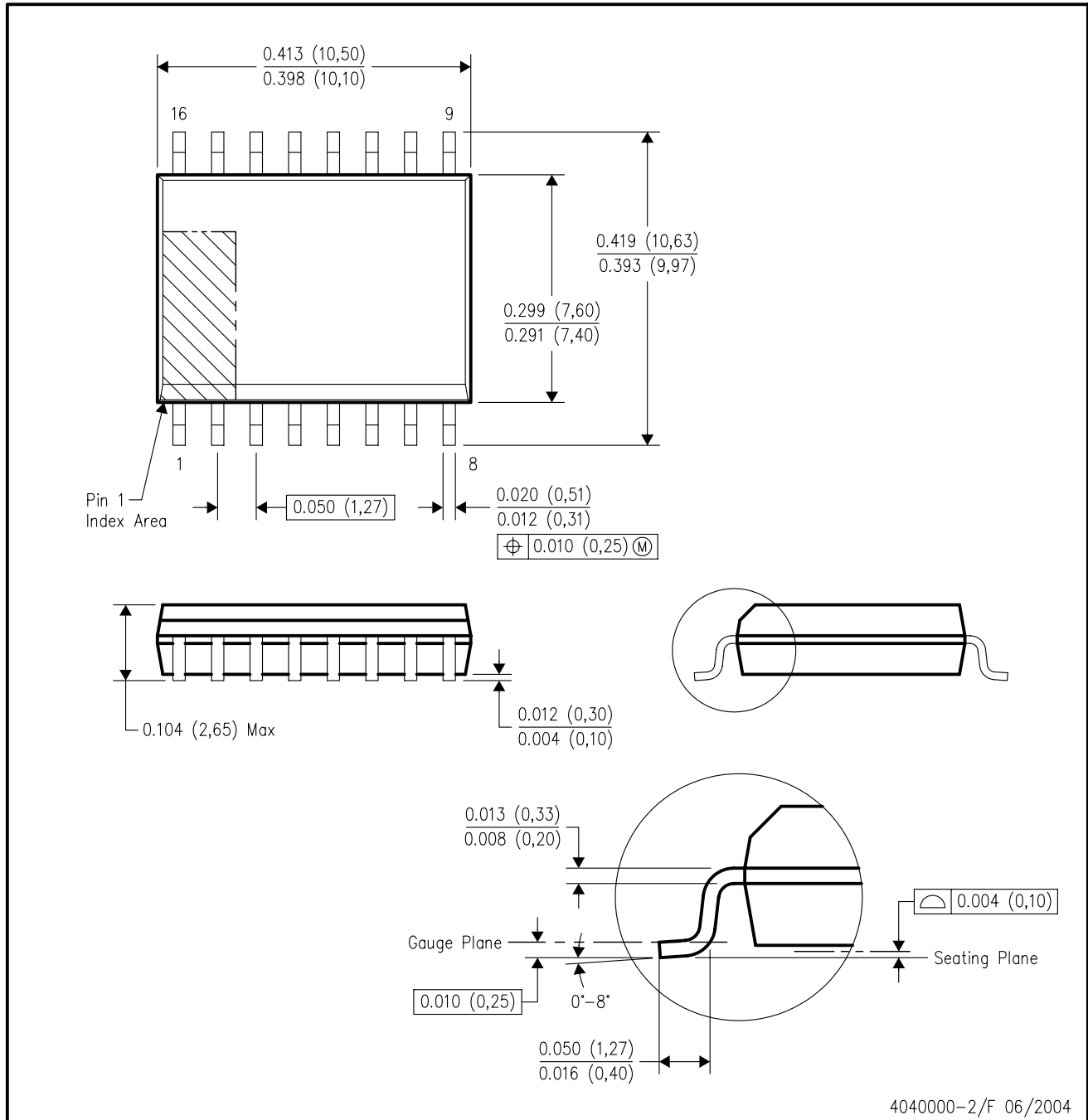

4040000-2/F 06/2004

- NOTES:
- A. All linear dimensions are in inches (millimeters).
 - B. This drawing is subject to change without notice.
 - C. Body dimensions do not include mold flash or protrusion not to exceed 0.006 (0,15).
 - D. Falls within JEDEC MS-013 variation AA.

DW (R-PDSO-G16)

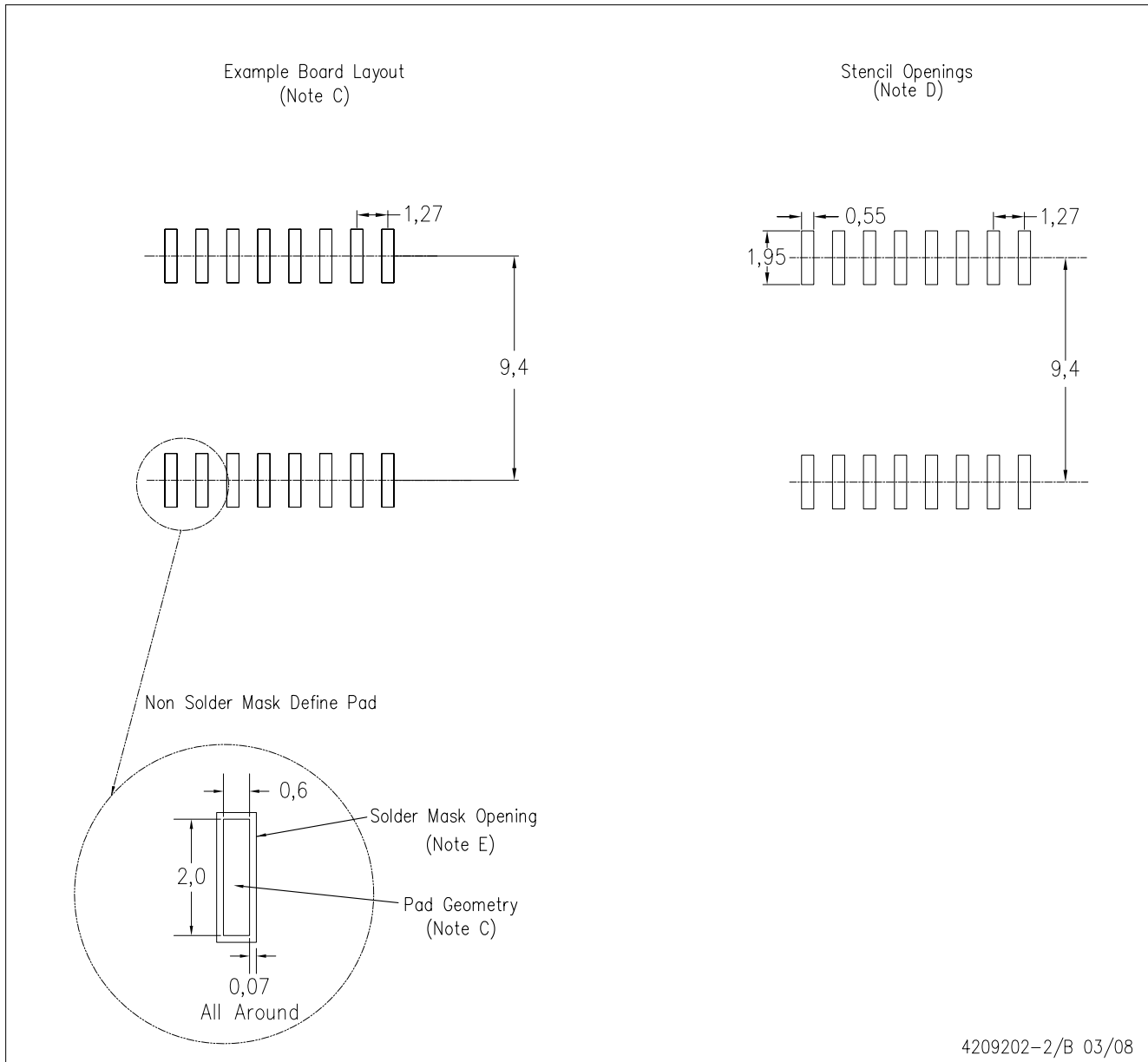

4209202-2/B 03/08

- NOTES:
- A. All linear dimensions are in millimeters.
 - B. This drawing is subject to change without notice.
 - C. Refer to IPC7351 for alternate board design.
 - D. Laser cutting apertures with trapezoidal walls and also rounding corners will offer better paste release. Customers should contact their board assembly site for stencil design recommendations. Refer to IPC-7525
 - E. Customers should contact their board fabrication site for solder mask tolerances between and around signal pads.

IMPORTANT NOTICE

Texas Instruments Incorporated and its subsidiaries (TI) reserve the right to make corrections, modifications, enhancements, improvements, and other changes to its products and services at any time and to discontinue any product or service without notice. Customers should obtain the latest relevant information before placing orders and should verify that such information is current and complete. All products are sold subject to TI's terms and conditions of sale supplied at the time of order acknowledgment.

TI warrants performance of its hardware products to the specifications applicable at the time of sale in accordance with TI's standard warranty. Testing and other quality control techniques are used to the extent TI deems necessary to support this warranty. Except where mandated by government requirements, testing of all parameters of each product is not necessarily performed.

TI assumes no liability for applications assistance or customer product design. Customers are responsible for their products and applications using TI components. To minimize the risks associated with customer products and applications, customers should provide adequate design and operating safeguards.

TI does not warrant or represent that any license, either express or implied, is granted under any TI patent right, copyright, mask work right, or other TI intellectual property right relating to any combination, machine, or process in which TI products or services are used. Information published by TI regarding third-party products or services does not constitute a license from TI to use such products or services or a warranty or endorsement thereof. Use of such information may require a license from a third party under the patents or other intellectual property of the third party, or a license from TI under the patents or other intellectual property of TI.

Reproduction of TI information in TI data books or data sheets is permissible only if reproduction is without alteration and is accompanied by all associated warranties, conditions, limitations, and notices. Reproduction of this information with alteration is an unfair and deceptive business practice. TI is not responsible or liable for such altered documentation. Information of third parties may be subject to additional restrictions.

Resale of TI products or services with statements different from or beyond the parameters stated by TI for that product or service voids all express and any implied warranties for the associated TI product or service and is an unfair and deceptive business practice. TI is not responsible or liable for any such statements.

TI products are not authorized for use in safety-critical applications (such as life support) where a failure of the TI product would reasonably be expected to cause severe personal injury or death, unless officers of the parties have executed an agreement specifically governing such use. Buyers represent that they have all necessary expertise in the safety and regulatory ramifications of their applications, and acknowledge and agree that they are solely responsible for all legal, regulatory and safety-related requirements concerning their products and any use of TI products in such safety-critical applications, notwithstanding any applications-related information or support that may be provided by TI. Further, Buyers must fully indemnify TI and its representatives against any damages arising out of the use of TI products in such safety-critical applications.

TI products are neither designed nor intended for use in military/aerospace applications or environments unless the TI products are specifically designated by TI as military-grade or "enhanced plastic." Only products designated by TI as military-grade meet military specifications. Buyers acknowledge and agree that any such use of TI products which TI has not designated as military-grade is solely at the Buyer's risk, and that they are solely responsible for compliance with all legal and regulatory requirements in connection with such use.

TI products are neither designed nor intended for use in automotive applications or environments unless the specific TI products are designated by TI as compliant with ISO/TS 16949 requirements. Buyers acknowledge and agree that, if they use any non-designated products in automotive applications, TI will not be responsible for any failure to meet such requirements.

Following are URLs where you can obtain information on other Texas Instruments products and application solutions:

Products		Applications	
Amplifiers	amplifier.ti.com	Audio	www.ti.com/audio
Data Converters	dataconverter.ti.com	Automotive	www.ti.com/automotive
DLP® Products	www.dlp.com	Communications and Telecom	www.ti.com/communications
DSP	dsp.ti.com	Computers and Peripherals	www.ti.com/computers
Clocks and Timers	www.ti.com/clocks	Consumer Electronics	www.ti.com/consumer-apps
Interface	interface.ti.com	Energy	www.ti.com/energy
Logic	logic.ti.com	Industrial	www.ti.com/industrial
Power Mgmt	power.ti.com	Medical	www.ti.com/medical
Microcontrollers	microcontroller.ti.com	Security	www.ti.com/security
RFID	www.ti-rfid.com	Space, Avionics & Defense	www.ti.com/space-avionics-defense
RF/IF and ZigBee® Solutions	www.ti.com/lprf	Video and Imaging	www.ti.com/video
		Wireless	www.ti.com/wireless-apps

Mailing Address: Texas Instruments, Post Office Box 655303, Dallas, Texas 75265
Copyright © 2010, Texas Instruments Incorporated