

THIS DRAWING IS UNPUBLISHED.

RELEASED FOR PUBLICATION

,19

© COPYRIGHT 19

BY AMP INCORPORATED. ALL RIGHTS RESERVED.

LOC	DIST	REVISIONS				
P	LTR	DESCRIPTION	DATE	DWN	APVD	
AF	50	E	REV PER OG3A-0289-01	18APR01	JR	EH

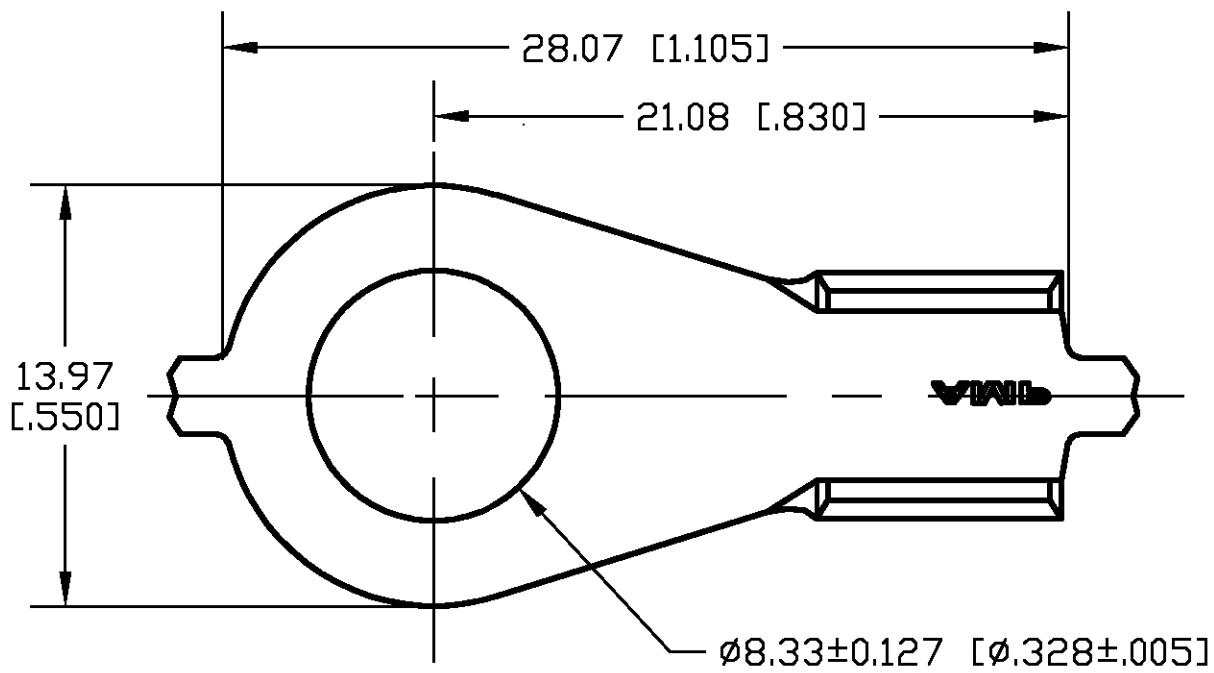

- 1 CONTINUOUS STRIP ON REELS.
- 2 0.00381 [0.00150] MIN TIN OVER 0.00254 [0.00100] MIN COPPER.
- 3 0.00381 [0.00150] MIN TIN
- 4 PRELIMINARY - NOT FOR PRODUCTION

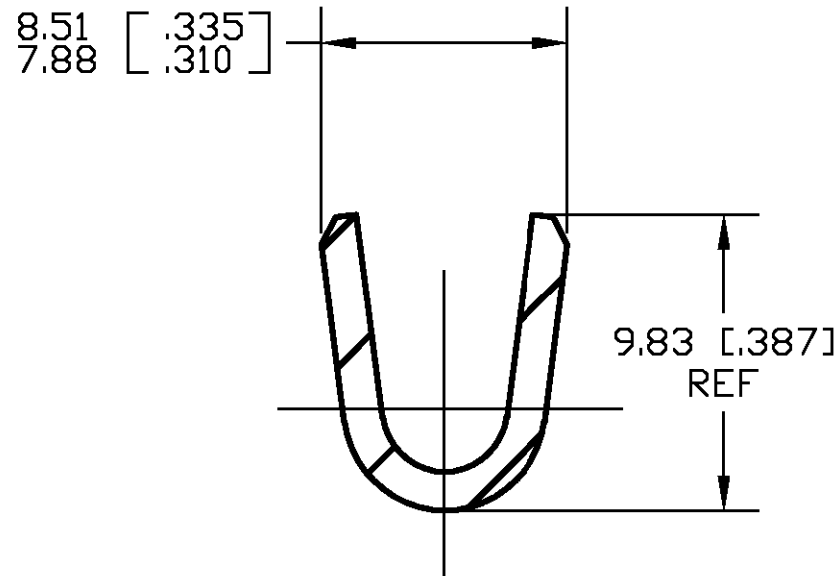
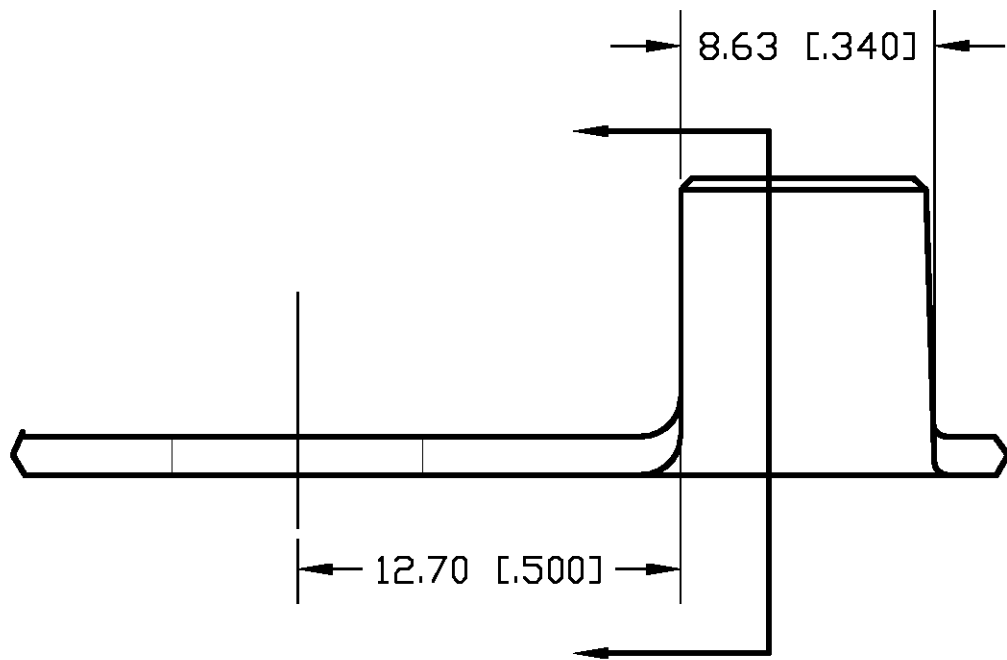

FINISH	MATERIAL	PART NUMBER
3	1.257±0.025[.0495±.001] H00 COPPER	4 61546-3
2	1.27±0.025[.050±.001] 082 BRASS	61546-1

THIS DRAWING IS A CONTROLLED DOCUMENT.		DWN JR RUTH 28JUN00	AMP AMP Incorporated Harrisburg, PA 17105-3608	
DIMENSIONS: IN [INCHES]		CHK MS FEHER 28JUN00		
TOLERANCES UNLESS OTHERWISE SPECIFIED:		APVD G PORTA 28JUN00	NAME RING TONGUE	
0 PLC ± -		PRODUCT SPEC	SIZE A3	
1 PLC ± -		APPLICATION SPEC	CAGE CODE 00779	DRAWING NO C-61546
2 PLC ± -		WEIGHT	RESTRICTED TO	
3 PLC ± -		CUSTOMER DRAWING	SCALE 3:1	
4 PLC ± -			SHEET 1 OF 1	
ANGLES ± 1		REV F		
MATERIAL SEE TABLE	FINISH SEE TABLE			