

THESE DRAWINGS ARE THE PROPERTY OF QUALTEK ELECTRONICS AND NOT TO BE REPRODUCED FOR OR COMMUNICATED TO A THIRD PARTY WITHOUT THE EXPRESS WRITTEN PERMISSION OF AN OFFICER OF QUALTEK ELECTRONICS.

REVISION			
REV.	DESCRIPTION	DATE	APPROVED
B	RoHS Compliancy	06-01-06	DP

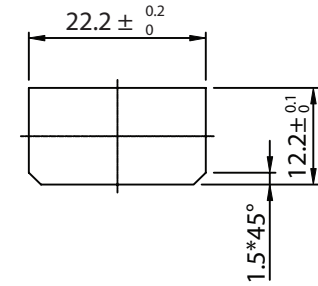

PANEL CUTOUT
Panel Thickness Range: 0.8mm ~ 2.0mm

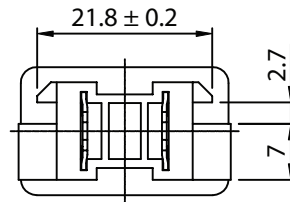
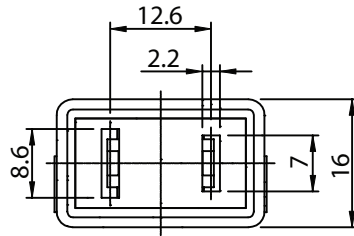
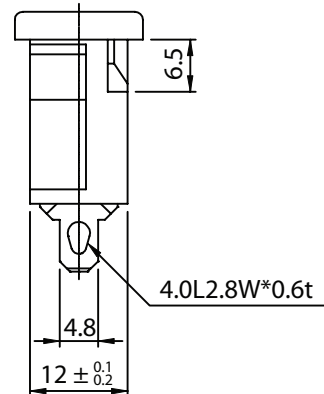
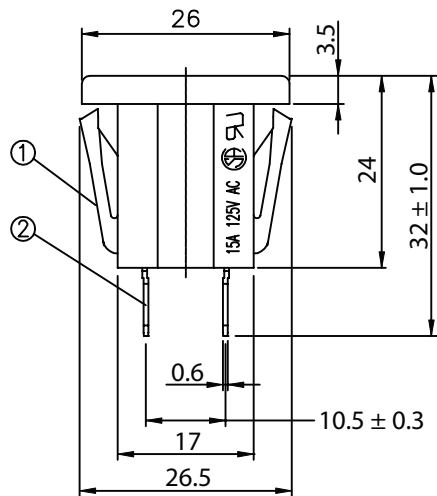

CONTROLLED

NOTES:

15A 125V AC
PANEL THICKNESS: 0.8~2.0mm
APPROVALS: UL, CSA
RoHS COMPLIANT

2	Soldering PIN(t) - 0.6mm Tin-Plated	2		
1	Body Insulator PC Black Color	1		
Qualtek Electronics Corp.				
PPC DIVISION				
Dim range (mm)	Tolerance +/- (mm)	Part Number: 738W-CX2/01 RoHS Compliant		
0-1	0.15	Description: SNAP-IN NEMA 1-15R		
1-6	0.20			
6-18	0.30	UNIT: mm		
18-50	0.50			
50-120	0.70	REV. B		
120-250	0.90	Drawn / Date	Checked / Date	Approved / Date
250-500	1.20	B.ZHANG 01-30-04	01-30-04	JJH / 01-30-04