

Thru-Bulkhead Receptacle

For SJTB See Page 51

- For feed through of circuits on bulkhead or panel
- Pin and socket double ended contacts
- Drilled and tapped mounting holes

TVB Intermates with MIL-C-38999 Series III connectors

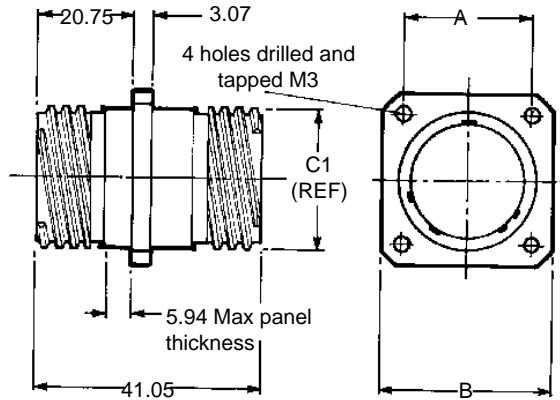

TVBK=Electroless nickel TVBW=Olive drab TVBB = Ni Al Bronze
Example part number: TVBW-25-35PSN(W52)

LJTB Intermates with MIL-C-38999 Series 1 connectors

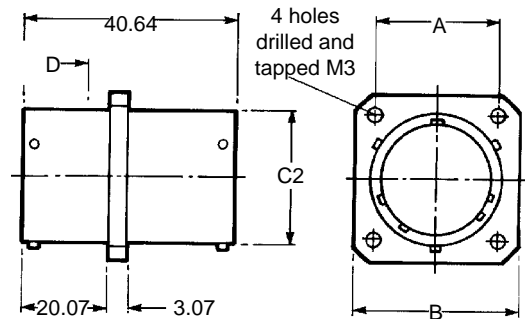

Example part number: LJTB-25-35PS(014)(W02)

| Shell size | A | B | C1 | C2 | D LJT Max Panel thickness |
|------------|-------|-------|-------|-------|---------------------------------|
| 9 | 18.26 | 23.83 | 15.88 | 14.53 | 5.18 |
| 11 | 20.62 | 26.19 | 19.05 | 17.78 | 5.18 |
| 13 | 23.01 | 28.58 | 22.25 | 21.59 | 5.18 |
| 15 | 24.61 | 30.96 | 27.94 | 24.77 | 5.18 |
| 17 | 26.97 | 33.32 | 30.15 | 27.94 | 5.18 |
| 19 | 29.36 | 36.53 | 31.75 | 30.66 | 5.18 |
| 21 | 31.75 | 39.67 | 34.93 | 33.83 | 5.18 |
| 23 | 34.93 | 42.88 | 38.10 | 37.01 | 5.18 |
| 25 | 38.10 | 46.02 | 41.28 | 40.18 | 4.90 |

Drilled and tapped mounting holes (W02) deviation

- Eases connector mounting
- Cost effective
- Alleviates the possibility of mounting nuts falling into equipment

Available in all square flange sizes

N.B Flange thickness is increased to 3.05

Example part number LJTP02RE1535PN(W02)

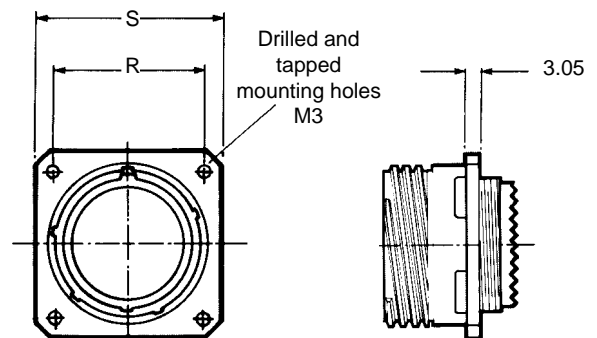

| Shell size | LJT/TV | |
|------------|--------|-------|
| | R | S |
| 9 | 18.26 | 23.83 |
| 11 | 20.62 | 26.19 |
| 13 | 23.01 | 28.58 |
| 15 | 24.61 | 30.96 |
| 17 | 26.97 | 33.32 |
| 19 | 29.36 | 36.53 |
| 21 | 31.75 | 39.67 |
| 23 | 34.93 | 42.88 |
| 25 | 38.10 | 46.02 |

| Shell size | SJT | |
|------------|-------|-------|
| | R | S |
| 8 | 15.09 | 20.62 |
| 10 | 18.26 | 23.80 |
| 12 | 20.62 | 26.19 |
| 14 | 23.01 | 28.55 |
| 16 | 24.61 | 30.96 |
| 18 | 26.97 | 33.30 |
| 20 | 29.36 | 36.53 |
| 22 | 31.75 | 39.67 |
| 24 | 34.93 | 41.35 |

All dimensions for reference only

Crimp Contacts

| Contact Size | SJT/JT/LJT Pins + TV | | JT Sockets | | SJT/LJT Sockets + TV | |
|--------------|----------------------|----------------|----------------|---------------|----------------------|---------------|
| | Proprietary No | MS Number | Proprietary No | MS Number | Proprietary No | MS Number |
| 8 (Coax) | 21-33102-21 | M39029/60-367 | NA | NA | 21-33101-21 | M39029/59-366 |
| 8 (Twinax) | 21-33190-529 | M39029/90-529† | NA | NA | 21-33191-530† | M39029/91-530 |
| 10 (Power) | 10-251415-105 | M39029/58-528 | NA | NA | 10-407035-105 | M39029/56-527 |
| 12 | 10-251415-12H | M39029/58-365 | 10-251416-125 | M39029/57-359 | 10-407035-125 | M39029/56-353 |
| 16 | 10-251415-165 | M39029/58-364 | 10-251416-165 | M39029/57-358 | 10-407035-165 | M39029/56-352 |
| 20 | 10-251415-205 | M39029/58-363 | 10-497401-205 | M39029/57-357 | 10-497403-205 | M39029/56-351 |
| 22 | 10-251415-225 | M39029/58-362 | 10-251416-225 | M39029/57-356 | 10-407035-225 | M39029/56-350 |
| 22M | 10-251415-235 | M39029/58-361 | 10-251416-235 | M39029/57-355 | 10-407035-235 | M39029/56-349 |
| 22D | 10-251415-725 | M39029/58-360 | 10-251416-725 | M39029/57-354 | 10-407035-725 | M39029/56-348 |

† for use with M17/M176-00002 cable.

Filler Plugs

| Contact Size | Sealing Plugs | |
|--------------|----------------|--------------|
| | Proprietary No | MS Number |
| 8 (Coax) | 10-482099-8 | NA |
| 8 (Twinax) | 10-405996-8-1 | MS27488-8-1 |
| 10 (Power) | 10-576225 | NA |
| 12 | 10-405996-12-1 | MS27488-12-1 |
| 16 | 10-405996-16-1 | MS27488-16-1 |
| 20 | 10-405996-20-1 | MS27488-20-1 |
| 22D | 10-405996-22-1 | MS27488-22-1 |

Dummy Contacts

| Dummy Contacts Size | |
|---------------------|----------|
| 8 Pin | 418-920P |
| 8 Sockets | 418-920S |

Thermocouple Contacts

| Contact Size | Material | JT/LJT/TV Pins | JT Sockets | LJT/TV Sockets |
|--------------|-------------|----------------|---------------|----------------|
| 20 | Chromel | 10-407862-310 | 10-407863-310 | 10-407865-310 |
| | Alumel | 10-407862-320 | 10-407863-320 | 10-407865-320 |
| | Iron | 10-407862-335 | 10-407863-335 | 10-407865-335 |
| | Constanstan | 10-407862-342 | 10-407863-342 | 10-407864-342 |

Premating Contacts

| SJT/LJT/JT/TV | Size 20 | Size 16 | Size 12 |
|---------------|-------------------|-------------------|-------------------|
| Pin Contact | 418-1038-2000P-02 | 418-1038-1600P-02 | 418-1038-1200P-02 |

Last Mate Contacts

| SJT/LJT/JT/TV | Size 20 | Size 16 | Size 12 |
|---------------|-------------------|-------------------|-------------------|
| Pin Contact | 418-1038-2001P-02 | 418-1038-1601P-02 | 418-1038-1201P-02 |

Heavy Duty Power Contacts

Size 8 Power Contacts rated at 60 amps. LJT, SJT, TV Series only.

8 AWG Cable:
Pin Contact 900-197
Socket Contact 900-217

10 AWG Cable:
Standard Contact plus Reducing Sleeve 900-154

Crimping Tools

| Contact Size/Type | Crimping Tool | Turret Die or Positioner | Contact Size/Type | Crimping Tool | Turret Die or Positioner |
|--|----------------------------|----------------------------|---------------------------------|----------------------------|---|
| 12 Pin and Socket | M22520/1-01 | M22520/1-04 | 8 Coaxial Inner Pin and Socket | M22520/2-01 | M22520/2-31 |
| 16 Pin and Socket | M22520/1-01 M22520/7-01 | M22520/1-04 M22520/7-04 | 8 Coaxial Outer Pin and Socket | M22520/5-01 M22520/5-01 | M22520/5--05 Die Closure B M22520/5-41 Die Closure B |
| 20 Pin and Socket | M22520/1-01 M22520/2-01 | M22520/1-04 M22520/2-10 | 16 Coaxial Inner Pin and Socket | M22520/10-01 | M22520/10-07 Die Closure B |
| 22, 22D, 22M Pin | M22520/7-01 M22520/2-01 | M22520/7-08 M22520/2-09 | 16 Coaxial Outer Pin and Socket | M22520/2-01 | M22520/2-35 |
| 22, 22D, 22M Socket (LJT-R) | M22520/7-01 M22520/2-01 | M22520/7-07 M22520/2-07 | 12 Coaxial Inner Pin and Socket | M22520/4-01 | M22520/4-02 |
| 22D Socket (JT-R) | M22520/7-01 | M22520/7-05 | 12 Coaxial Outer Pin and Socket | M22520/2-01 | M22520/2-34 |
| 8 Twinax Centre Pin and Socket | M22520/7-01 | M22520/7-06 | 10 (Power) | *CONSULT | FACTORY |
| 8 Twinax Intermediate Outer Pin & Socket | M22520/2-01 | M22520/2-37 | | | |
| | M22520/5-01 | M22520/5-200 | | | |

Where 2 or 3 tools are listed for a contact size, only one tool and its die or positioner are required to crimp the contact. The above crimping tools and positioners are available from the approved tool manufacturer.

Insertion Tools

| Use With Contact Size | Plastic Tools | | Metal Tools | | | |
|-----------------------|---------------|------------------|----------------|-------------------------|-------------------------|--------|
| | Part Number | Colour | Angle Type | | Straight Type | Colour |
| | | | MS Part Number | Proprietary Part Number | Proprietary Part Number | |
| 12 | M81969/14-04 | Yellow / (White) | M81969/8-09 | 11-8674-12 | 11-8794-12 | Yellow |
| 16 | M81969/14-03 | Blue / (White) | M81969/8-07 | 11-8674-16 | 11-8794-16 | Blue |
| 20 | M81969/14-10 | Red / (Orange) | M81969/8-05 | 11-8674-20 | 11-8794-20 | Red |
| 22 | M81969/14-09 | Brown / (White) | M81969/8-03 | 11-8674-22 | 11-8794-22 | Brown |
| 22D, 22M | M81969/14-01 | Green / (White) | M81969/8-01 | 11-8674-24 | 11-8794-24 | Black |
| 8 Coaxial | None Required | | | | | |
| 8 Twinax | None | | M81969/46-06 | None | | Red |

Removal Tools

| Use With Contact Size | Plastic Tools | | Metal Tools | | | | |
|-----------------------|---------------|------------------|--|----------------|-------------------------|---------------------|----------------|
| | Part Number | Colour Code | For Unwired Contacts Proprietary Part Number | Angle Type | | Straight Type | Colour Code |
| | | | | MS Part Number | Proprietary Part Number | Proprietary Part No | |
| 12 | M81969/14-04 | (Yellow) / White | 11-10050-11 | M81969/8-10 | 11-8675-12 | 11-8795-12 | Yellow / White |
| 16 | M81969/14-03 | (Blue) / White | 11-10050-10 | M81969/8-08 | 11-8675-16 | 11-8795-16 | Blue / White |
| 20 | M81969/14-10 | (Red) / Orange | 11-10050-9 | M81969/8-06 | 11-8675-20 | 11-8795-20 | Red / White |
| 22 | M81969/14-09 | (Brown) / White | 11-10050-8 | M81969/8-04 | 11-8675-22 | 11-8795-22 | Brown / White |
| 22D, 22M | M81969/14-01 | (Green) / White | 11-10050-7 | M81969/8-02 | 11-8675-24 | 11-8795-24 | Black / White |
| 8 Coaxial | M81969/14-12 | Green | None | None | 11-9170 | DRK264-8 | N/A |
| 8 Twinax | M81969/14-12 | Green | None | M81969/46-12 | 11-9170 | N/A | N/A |

Low Profile MIL-STD 1760 Breakaway - D38999/31 Style 1 Approved

- Swivel Lanyard
- Moisture / Ice Resistant
- Approved to D38999 / 31 , JN1034, complies with Stanag 3837AA
- Insert arrangement compatible with MIL-STD-1553B databus

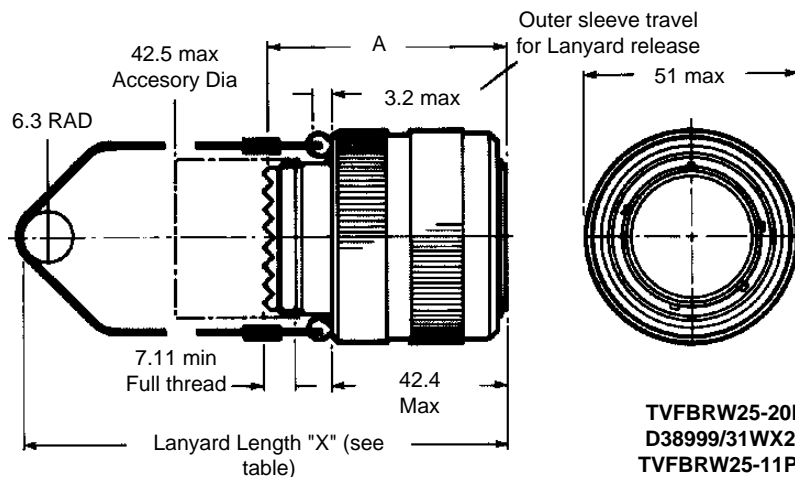

| Shell size * | A max dia |
|--------------|-----------|
| 11 | 33.02 |
| 13 | 36.02 |
| 15 | 39.52 |
| 17 | 41.00 |
| 19 | 41.00 |
| 23 | 47.42 |
| 25 | 51.00 |

| Lanyard code* | Length ±6mm |
|---------------|-------------|
| D | 140 |
| E | 153 |
| F | 166 |
| G | 178 |
| H | 191 |
| K | 229 |
| M | 254 |
| J | 407 |
| X | 432 |

* Other sizes available on request

- For MIL-STD-1760 applications only, 25-20 and 25-11 inserts should be used

| Contact size | Under D38999/31 | | Socket Contacts | |
|--------------|------------------------------------|---------------|--------------------|---------------|
| | Pin contacts Proprietary Number | MS Number | Proprietary Number | MS Number |
| 8 (twinax) | 21-33190-529 | M39029/90-529 | 21-33191-530 | M39029/91-530 |
| 10 (power) | 10-251415-105 | M39029/58-528 | 10-407035-105 | M39029/56-527 |
| 12 (coax) | 21-33122-546 | M39029/28-211 | 21-33123-546 | M39029/75-418 |
| 16 (power) | 10-251415-165 | M39029/58-364 | 19-407035-165 | M39029/56-352 |
| 20 (power) | 10-251415-205 | M39029/58-363 | 10-497403-205 | M39029/91-351 |

| Contact size | Under TVFBRW 25 | | Under JN1034E | |
|--------------|------------------------------------|-----------------|------------------------------------|-----------------|
| | Pin contacts Proprietary Number | Socket Contacts | Pin contacts Proprietary Number | Socket Contacts |
| 8 (twinax) | 711-1760-1-14 | 711-1760-2-14 | 711-1760-1-32 | 711-1760-2-32 |
| 10 (power) | 10-251415-105 | 10-407935-105 | | |
| 12 (coax) | 21-33122-546 | 21-33123-546 | 21-33122-546 | 21-33123-546 |
| 16 (power) | 10-251415-165 | 10-407035-165 | 10-251415-165 | 10-407035-165 |
| 20 (power) | 10-251415-205 | 10-497403-205 | 10-251415-205 | 10-497403-205 |

Append "L/C" to part number if no contacts are required
All dimensions are for reference only

Printed Circuit Board Contacts

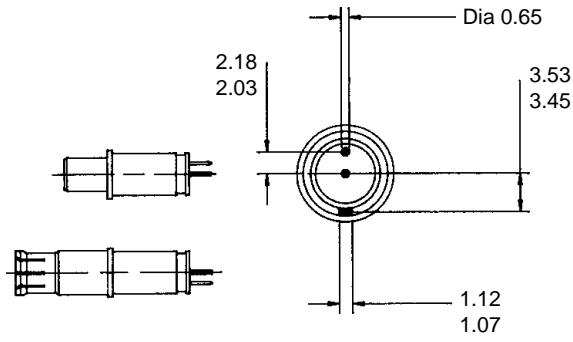

711GB-0329-1
711GB-0329-2

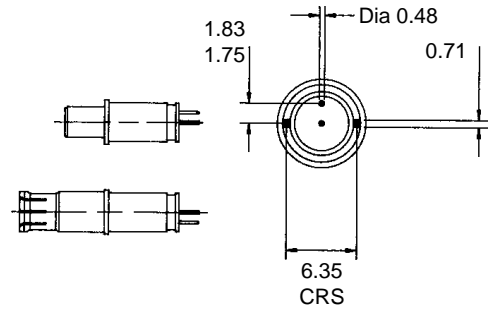

711-1760-1PC
711-1760-2PC
711-1760-3PC



418-1440-1200P-IPC

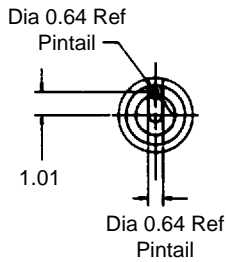
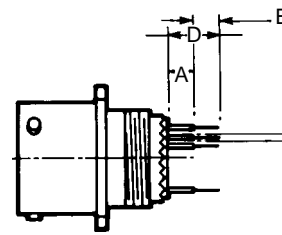

418-1608-1600S-IPC

| | TV07 | TV06 | TVP00 | LJT00 | LJT06 | LJTPQ00 | LJT07 #9 | LJT07 #19-25 | LJTP02 | LJT02 | JTPQ00 #8 | JT06 #8 | JT00 #8 | JT07 #8 | JTPQ00 #24 | JT06 #24 | JT07 #24 | JT00 #24 | SJT06 #8 | SJT00 #8 | SJT00 #24 | SJT07 #8-16 | SJT07 #18-24 | |
|---------------------|------|------|-------|-------|-------|---------|----------|--------------|--------|-------|-----------|---------|---------|---------|------------|----------|----------|----------|----------|----------|-----------|-------------|--------------|---|
| Size 8 Data Bus Pin | B | D | D | D | D | D | D | D | D | D | D | D | D | D | D | D | D | D | D | D | D | D | D | D |
| 711GB-0329-1 | 4,32 | 4,32 | 4,32 | 4,98 | 4,39 | 4,60 | 4,43 | 3,75 | 10,16 | 7,87 | 8,31 | 8,31 | 8,31 | 8,31 | 6,58 | 6,58 | 6,58 | 6,58 | 3,66 | 4,98 | 3,58 | NS | NS | |
| 711-1760-1PC | 2,79 | 2,79 | 2,79 | 3,48 | 2,87 | 3,10 | 3,00 | 2,25 | 8,66 | 6,38 | 6,81 | 6,81 | 6,81 | 6,81 | 5,08 | 5,08 | 5,08 | 5,08 | 2,16 | 3,48 | 2,08 | NS | NS | |

| Size 8 Data Bus Socket | B | D | D | D | D | D | D | D | D | D | D | D | D | D | D | D | D | D | D | D | D | D | D | |
|------------------------|------|------|------|------|------|------|------|------|-------|--------------------|---|---|---|---|---|---|---|---|---|------|------|------|----|----|
| 711GB-0329-2 | 4,10 | 4,10 | 4,10 | 4,78 | 4,17 | 4,39 | 4,24 | 3,75 | 9,96 | TV, LJT & SJT ONLY | | | | | | | | | | 3,45 | 4,78 | 3,38 | NS | NS |
| 711-1760-2PC | 2,59 | 2,59 | 2,59 | 3,28 | 2,67 | 2,90 | 2,74 | 2,25 | 8,46 | TV, LJT & SJT ONLY | | | | | | | | | | 1,96 | 3,28 | 1,88 | NS | NS |
| 711-1760-3PC | 4,76 | 4,76 | 4,76 | 5,44 | 4,83 | 5,05 | 4,90 | 4,41 | 10,62 | TV, LJT & SJT ONLY | | | | | | | | | | 4,11 | 5,44 | 4,04 | NS | NS |

| Size 12 Coax Pin | B | D | D | D | D | D | D | D | D | D | D | D | D | D | D | D | D | D | D | D | D | D | D |
|--------------------|------|------|------|------|------|------|------|------|------|------|------|------|------|------|------|------|------|------|------|------|----|----|---|
| 418-1440-1200P-1PC | 2,79 | 2,79 | 2,79 | 3,48 | 2,87 | 3,10 | 3,00 | 2,25 | 8,66 | 6,38 | 6,81 | 6,81 | 6,81 | 5,08 | 5,08 | 5,08 | 5,08 | 5,16 | 3,48 | 2,08 | NS | NS | |

| Size 16 Coax Socket | B | D | D | D | D | D | D | D | D | D | D | D | D | D | D | D | D | D | D | D | D | D | D | |
|---------------------|------|------|------|------|------|------|------|------|-------|--------------------|---|---|---|---|---|---|---|---|---|------|------|------|----|----|
| 418-1608-1600S-1PC | 4,48 | 4,47 | 4,47 | 5,16 | 4,55 | 4,78 | 4,62 | 4,13 | 10,34 | TV, LJT & SJT ONLY | | | | | | | | | | 3,84 | 5,16 | 3,76 | NS | NS |

All dimensions for reference only

Coaxial Contacts

| Contacts | | P/S | Size | Cable | Crimping Tools | |
|-----------------------------------|-------------------------------|-----|------|--|--|--|
| LJT/TV/SJT | JT | | | | Inner Contact | Crimp Ferrule |
| 418-840-16001-02 M39029/76-424 | | P | 16 | RG179B/U RG174a/U RG188A/U | MIL-C-22520/2-01 with positioner M22520/2-35 or Daniels Positioner K32 | M22520/4-01 with positioner M2520/4-02 |
| 418-841-16001-02 M39029/77-428 | 21-33121-563 M39029/78-432 | S | 16 | RG316/U RG161/U RG187A/U | MIL-C-22520/2-01 with positioner M22520/2-34 or Daniels Positioner 323 | M22520/31-01 Positioner M22520/31-02 or Daniels G5200 Tool Positioner G2P330 |
| 418-840-12001-02 M39029/28-211 | | P | 12 | Teledyne 11299 Times (HS-179) AA3248 | | |
| 418-841-12001-02 M39029/75-416 | 21-33121-546 M39029/27-210 | S | 12 | | | |

Partial Lists - Please see "Coaxial Contacts" catalogue for other contacts available

Short #8 MIL-STD-1553B Contacts for 1760 Interfaces

Contacts designed to meet the requirements of MIL-C-39029/90A (PIN) and 91A (Socket). For use in aircraft stores management interfaces.

711-1760-X-X X

| | |
|---|--|
| Series Designator | Variation (Cable accepted) 1- Raychem EPD 221898 & 10614 Grumman GC 875 F24H 2- Raychem 10613 711 Series - Pan 6421 3- McDonnell Douglas SM2022/003 4- Tensolite M17/176.00002 Raychem 10612 5- Rychem 10606 6- Raychem EPD 2984A |
| Contact Style 1=Pin 2=Socket | |
| Sealing Style 0=No seal supplied 1=1760/heatshrink boot 2=38999/cable grommet 3=Improved cable grommet | |

*JN1057-X 711-1760-X-XX in situ dimensions

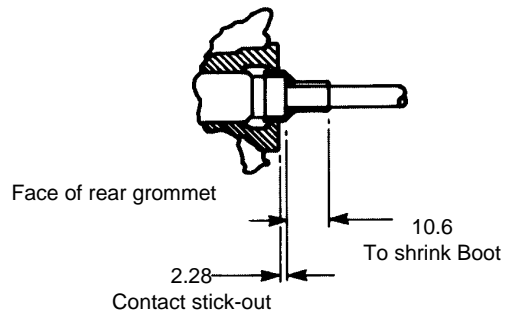

M39029/90/91A in situ dimensions

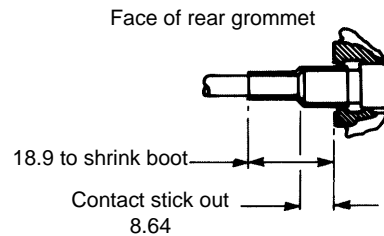

Contacts are of a four piece weight reduced design and utilises the MIL-Spec tooling listed below-

For centre contact crimp - Positioner Part No. 294GB 5049

Hand tool M22520/2-01

For intermediate & outer Die Part No 294GB 5050

Body crimps Hand tool M22520/5-01

Printed Circuit Board Contacts

| | Tail Dia "C" | Tail Length "B" | TV07/TV06 TVP00 | LJT00 LJT06 LJTPQ00 | LJT07 #9-15 | LJT07 #17-25 | LJT02/JTP02 LJTP02/JT02 | JTP000 #8-22 JT06 #8-22 | JT00 #8-22 JT07 #8-22 | JTPQ00/JT06 #24 JT07/JT00 #24 | SJT06 SJT00 #8-22 | SJT00 #24 | SJT07 #8-16 | SJT07 #18-24 | |
|-------------------|--------------|-----------------|-----------------|---------------------|-------------|--------------|-------------------------|-------------------------|-----------------------|-------------------------------|-------------------|-----------|-------------|--------------|------|
| Pin size 16 | C | B | A | A | A | A | A | A | A | A | A | A | A | A | |
| 418-926-1600P-02 | 1.22 | 2.95 | 5.74 | 6.40 | 6.02 | 5.87 | 5.38 | 11.58 | 9.32 | 9.78 | 8.03 | 6.40 | 5.00 | NS | NS |
| 418-1086-1600P-02 | 0.99 | 8.64 | 6.71 | 7.37 | 6.99 | 6.83 | 6.35 | 12.55 | 10.29 | 10.74 | 8.97 | 7.37 | 5.97 | 1.96 | NS |
| 418-1229-1600P-02 | 1.22 | 3.99 | 9.58 | 10.24 | 9.86 | 9.70 | 9.22 | 15.42 | 13.16 | 13.61 | 11.86 | 10.24 | 8.84 | 4.83 | 4.04 |
| 418-926-1602P-02 | 1.14 | 8.00 | 9.80 | 10.46 | 10.08 | 9.93 | 9.45 | 15.65 | 13.39 | 13.84 | 12.09 | 10.46 | 9.07 | 5.05 | 4.27 |

| Socket size 16 | C | B | A | A | A | A | A | A | A | A | A | A | A | A | A |
|-------------------|------|------|------|------|------|------|------|-------|-----------------|---|---|------|------|------|----|
| 418-1086-1600S-02 | 1.04 | 8.64 | 6.73 | 7.39 | 7.01 | 6.86 | 6.35 | 12.57 | LJT SJT TV only | | | 7.39 | 5.99 | 1.98 | NS |

*Ref to drawing below (Wire Wrap Contacts)

Wire Wrap Contacts

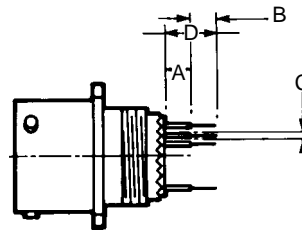

| | Tail Square "C" | Tail Length "B" | TV07/TV06 TVP00 | LJT00 LJT06 LJTP000 | LJT07 #9-15 | LJT07 #17-25 | LJT02/JTP02 LJTP02/JT02 | JTP000 #8-22 JT06#8-22 | JT00 #8-22 JT07 #8-22 | JTP000/JT06 #24 JT07/JT00 #24 | SJT06 SJT00 #8-22 | SJT00 #24 | SJT07 #8-16 | SJT07 #18-24 | |
|------------------|-----------------|-----------------|-----------------|---------------------|-------------|--------------|-------------------------|------------------------|-----------------------|-------------------------------|-------------------|-----------|-------------|--------------|-------|
| Pin #22D | C | B | A | A | A | A | A | A | A | A | A | A | A | A | |
| 418-982-22001-02 | 0.63 | 11.94 | 6.20 | 6.86 | 6.48 | 6.32 | 5.84 | 12.03 | 9.78 | 10.24 | 8.48 | 6.86 | 5.46 | NS | NS |
| 418-982-2202P-02 | 0.63 | 15.54 | 15.34 | 16.00 | 15.62 | 15.47 | 14.99 | 21.18 | 18.92 | 19.38 | 17.63 | 16.00 | 14.60 | 10.59 | 9.80 |
| 418-982-2200P-02 | 0.63 | 12.62 | 17.83 | 18.49 | 18.11 | 17.96 | 17.47 | 22.61 | 21.41 | 21.87 | 20.17 | 18.49 | 17.09 | 13.08 | 12.29 |

| Socket#22D | C | B | A | A | A | A | A | A | A | A | A | A | A | A | A |
|------------------|------|-------|-------|-------|-------|-------|-------|-------|----------|---|---|-------|-------|-------|-------|
| 418-982-2202S-02 | 0.64 | 15.54 | 15.06 | 15.72 | 15.34 | 15.19 | 14.68 | 20.90 | LJT only | | | 15.72 | 14.33 | 10.31 | 9.53 |
| 418-982-2200S-02 | 0.64 | 12.75 | 17.55 | 18.21 | 17.83 | 17.68 | 17.17 | 23.39 | LJT only | | | 18.21 | 16.81 | 12.80 | 12.01 |

| Pin#20 | C | B | A | A | A | A | A | A | A | A | A | A | A | A | A |
|------------------|------|-------|-------|-------|-------|-------|-------|-------|-------|-------|-------|-------|-------|-------|------|
| 418-982-2002P-02 | 0.64 | 15.54 | 15.34 | 16.00 | 15.62 | 15.47 | 24.13 | 21.18 | 18.92 | 19.38 | 17.63 | 16.00 | 14.61 | 10.59 | 9.80 |

| Socket #20 | C | B | A | A | A | A | A | A | A | A | A | A | A | A | A |
|-------------------|------|-------|-------|-------|-------|-------|-------|-------|----------|---|---|-------|-------|-------|------|
| 418-1086-2002S-02 | 0.64 | 15.70 | 15.04 | 15.54 | 15.34 | 15.19 | 14.68 | 20.90 | LJT only | | | 15.72 | 14.33 | 10.31 | 9.50 |

All dimensions are nominal, "NS" Designates no stick out, "#" designates shell size
To ensure grommet sealing - stickout dimensions should be equal to or greater than contact tail length

Printed Circuit Board Contacts

- Can be supplied fitted or loose
- Standard insert extraction tools
- Gold plating in accordance with MIL-C-39029
- Can be used with Harwin Sockets

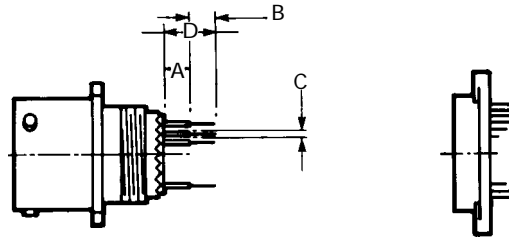

| | Tail Dia "C" | Tail Length "B" | TV07/TV06 | LJT00 | LJT06 | LJTPQ00 | LJT07 #9-15 | LJT07 #17-25 | LJT02/JTP02 | LJTP02/JT02 | JTP00/JT06 #8-22 | JT00/JT07#8-22 | JTPQ00/JT06 /JT07/JT00# | SJT06 | SJT00 #8-22 | SJT00 #24 | SJT07 #8-16 | SJT07 #18-24 |
|-------------------|--------------|-----------------|-----------|-------|-------|---------|-------------|--------------|-------------|-------------|------------------|----------------|-------------------------|-------|-------------|-----------|-------------|--------------|
| Pin size #22D | C | B | D | D | D | D | D | D | D | D | D | D | D | D | D | D | D | D |
| 418-1227-2200P-02 | 0.027 | 0.122 | NS | NS | NS | NS | NS | NS | 0.163 | 0.073 | 0.091 | NS | NS | NS | NS | NS | NS | NS |
| 418-923-2200P-02 | 0.024 | 0.158 | NS | NS | NS | NS | NS | NS | 0.217 | 0.128 | 0.146 | 0.077 | NS | NS | NS | NS | NS | NS |
| 418-818-2200P-02 | 0.028 | 0.157 | 0.062 | 0.088 | 0.073 | 0.067 | NS | NS | 0.292 | 0.203 | 0.221 | 0.152 | 0.088 | NS | NS | NS | NS | NS |
| 418-929-22001-02 | 0.019 | 0.160 | 0.123 | 0.149 | 0.134 | 0.128 | 0.109 | NS | 0.353 | 0.264 | 0.282 | 0.213 | 0.149 | 0.094 | NS | NS | NS | NS |
| 418-1075-2200P-02 | 0.019 | 0.118 | 0.167 | 0.193 | 0.178 | 0.172 | 0.153 | NS | 0.397 | 0.308 | 0.326 | 0.266 | 0.193 | 0.138 | NS | NS | NS | NS |
| 418-926-2200P-02 | 0.019 | 0.118 | 0.189 | 0.215 | 0.200 | 0.194 | 0.175 | NS | 0.419 | 0.330 | 0.348 | 0.279 | 0.215 | 0.160 | NS | NS | NS | NS |
| 418-1228-2200P-02 | 0.015 | 0.138 | 0.233 | 0.259 | 0.244 | 0.238 | 0.219 | NS | 0.463 | 0.374 | 0.382 | 0.323 | 0.259 | 0.204 | NS | NS | NS | NS |
| 418-1086-2200P-02 | 0.019 | 0.348 | 0.264 | 0.290 | 0.275 | 0.269 | 0.250 | NS | 0.494 | 0.405 | 0.423 | 0.353 | 0.290 | 0.235 | 0.077 | NS | NS | NS |
| 418-926-2201P-02 | 0.019 | 0.276 | 0.346 | 0.373 | 0.376 | 0.352 | 0.333 | NS | 0.577 | 0.488 | 0.506 | 0.437 | 0.373 | 0.318 | 0.160 | 0.129 | NS | NS |
| 418-926-2202P-02 | 0.019 | 0.315 | 0.386 | 0.412 | 0.397 | 0.391 | 0.372 | NS | 0.616 | 0.527 | 0.545 | 0.476 | 0.412 | 0.357 | 0.199 | 0.168 | NS | NS |
| 418-929-22004 | 0.019 | 0.253 | 0.554 | 0.580 | 0.565 | 0.559 | 0.540 | NS | 0.784 | 0.695 | 0.713 | 0.644 | 0.580 | 0.525 | 0.367 | 0.336 | NS | NS |

| Socket size 22D | C | B | D | D | D | D | D | D | D | D | D | D | D | D | D | D | D |
|-------------------|-------|-------|--------------------|-------|-------|-------|-------|----|-------|-----------------|-------|-------|--------------------|----|----|----|----|
| 418-923-2200S-02 | 0.023 | 0.158 | NS | NS | NS | NS | NS | NS | 0.206 | LJT SJT TV only | NS | NS | NS | NS | NS | NS | NS |
| 418-1075-2200S-02 | 0.019 | 0.119 | 0.165 | 0.191 | 0.176 | 0.170 | 0.150 | NS | 0.395 | LJT SJT TV only | 0.191 | 0.136 | NS | NS | NS | NS | NS |
| 418-926-2200S-02 | 0.019 | 0.118 | 0.178 | 0.204 | 0.189 | 0.183 | 0.164 | NS | 0.408 | LJT SJT TV only | 0.204 | 0.149 | NS | NS | NS | NS | NS |
| 418-818-2200S-02 | 0.028 | 0.157 | JT connectors only | | | | | | 0.438 | 0.348 | 0.366 | 0.297 | JT connectors only | | | | |
| 418-1077-2200S-02 | 0.027 | 0.290 | 0.241 | 0.267 | 0.252 | 0.246 | 0.226 | NS | 0.471 | LJT SJT TV only | 0.267 | 0.212 | NS | NS | NS | NS | NS |
| 418-1086-2200S-02 | 0.019 | 0.340 | 0.265 | 0.291 | 0.276 | 0.270 | 0.250 | NS | 0.495 | LJT SJT TV only | 0.291 | 0.236 | 0.078 | NS | NS | NS | NS |

| Pin size 20 | C | B | D | D | D | D | D | D | D | D | D | D | D | D | D | D | D |
|-------------------|-------|-------|-------|-------|-------|-------|-------|----|-------|-------|-------|-------|-------|-------|-------|-------|----|
| 418-916-2000P-02 | 0.024 | 0.100 | NS | NS | NS | NS | NS | NS | 0.230 | 0.141 | 0.159 | 0.090 | NS | NS | NS | NS | NS |
| 418-1226-2000P-02 | 0.020 | 0.125 | 0.129 | 0.155 | 0.140 | 0.134 | 0.115 | NS | 0.359 | 0.270 | 0.288 | 0.219 | 0.155 | NS | NS | NS | NS |
| 418-926-2000P-02 | 0.048 | 0.116 | 0.226 | 0.252 | 0.237 | 0.231 | 0.212 | NS | 0.456 | 3.670 | 0.385 | 0.316 | 0.232 | 0.197 | NS | NS | NS |
| 418-1086-2000P-02 | 0.039 | 0.340 | 0.265 | 0.290 | 0.275 | 0.269 | 0.250 | NS | 0.494 | 0.405 | 0.423 | 0.353 | 0.290 | 0.235 | 0.077 | NS | NS |
| 418-1205-2000P-02 | 0.028 | 0.196 | 0.309 | 0.333 | 0.320 | 0.314 | 0.295 | NS | 0.539 | 0.450 | 0.468 | 0.399 | 0.330 | 0.280 | 0.122 | 0.091 | NS |
| 418-1229-2000P-02 | 0.048 | 0.157 | 0.377 | 0.403 | 0.388 | 0.382 | 0.363 | NS | 0.607 | 0.518 | 0.536 | 0.467 | 0.403 | 0.348 | 0.19 | 0.159 | NS |
| 418-929-2000P-02 | 0.045 | 0.315 | 0.386 | 0.412 | 0.397 | 0.391 | 0.372 | NS | 0.616 | 5.270 | 0.545 | 0.476 | 0.412 | 0.357 | 0.199 | 0.168 | NS |

| Socket Size 20 | C | B | D | D | D | D | D | D | D | D | D | D | D | D | D | D | |
|-------------------|-------|-------|--------------------|-------|-------|-------|-------|----|-------|-----------------|-------|-------|--------------------|-------|----|----|--|
| 418-818-2000S-02 | 0.028 | 0.157 | JT Connectors only | | | | | | 0.174 | 0.084 | 0.102 | NS | JT Connectors only | | | | |
| 418-1086-1600S-02 | 0.039 | 0.340 | 0.265 | 0.291 | 0.276 | 0.270 | 0.250 | NS | 0.495 | LJT SJT TV only | 0.291 | 0.236 | 0.078 | NS | NS | NS | |
| 418-1205-2000S-02 | 0.028 | 0.197 | 0.302 | 0.328 | 0.313 | 0.307 | 0.287 | NS | 0.532 | LJT SJT TV only | 0.328 | 0.273 | 0.115 | 0.084 | NS | NS | |

| Pin Size #16 | C | B | D | D | D | D | D | D | D | D | D | D | D | D | D | D |
|-------------------|-------|-------|-------|-------|-------|-------|-------|----|-------|-------|-------|-------|-------|-------|-------|-------|
| 418-926-1600P-02 | 0.048 | 0.116 | 0.226 | 0.252 | 0.237 | 0.231 | 0.212 | NS | 0.456 | 0.367 | 0.385 | 0.316 | 0.252 | 0.197 | NS | NS |
| 418-1086-1600P-02 | 0.039 | 0.340 | 0.264 | 0.290 | 0.275 | 0.269 | 0.250 | NS | 0.494 | 0.405 | 0.423 | 0.353 | 0.290 | 0.235 | 0.077 | NS |
| 418-1229-1600P-02 | 0.048 | 0.157 | 0.377 | 0.403 | 0.388 | 0.382 | 0.363 | NS | 0.607 | 0.518 | 0.536 | 0.467 | 0.403 | 0.348 | 0.19 | 0.159 |
| 418-926-1600P-02 | 0.045 | 0.315 | 0.386 | 4.120 | 0.397 | 0.391 | 0.372 | NS | 0.616 | 0.527 | 0.545 | 0.476 | 0.412 | 0.357 | 0.199 | 0.168 |

| Socket Size #16 | C | B | D | D | D | D | D | D | D | D | D | D | D | D | D |
|-------------------|-------|-------|-------|-------|-------|-------|-------|----|-------|-----------------|-------|-------|-------|----|----|
| 418-1086-1600S-02 | 0.041 | 0.340 | 0.265 | 0.291 | 0.276 | 0.270 | 0.250 | NS | 0.495 | LJT SJT TV only | 0.291 | 0.236 | 0.078 | NS | NS |

"NS" Designates no stick out. # Designates Shell Size

To ensure grommet sealing - stickout dimensions should be equal to or greater than contact tail length

Multi-mode termini, size 16 for multi-channel cylindrical fibre optic connectors features, how to order

Amphenol® Multi-mod16 Termini
Features and Performance Levels:

- Ceramic alignment ferrule which precisely positions the fibre within the termini.
- Stainless steel alignment sleeve, assembled on the socket after polishing insures accurate fibre to fibre alignment (a ceramic alignment sleeve is also available).
- Typical insertion loss for 100/140fibre with .2NA at 820nm is .5 to .7 dB using Air Gap (AG) polish
Use of the ceramic ferrule and sleeve maximises the ability to hold extremely tight dimensional tolerances while maintaining accurate concentricity, thus providing superior and consistent optical loss performance.
- Termination accomplished using the industry proven epoxy/polish method. Can be polished Air Gap (AG) or Physical Contact (PC).
Socket cleaning optional. Consult Amphenol, for termini cleaning tool.

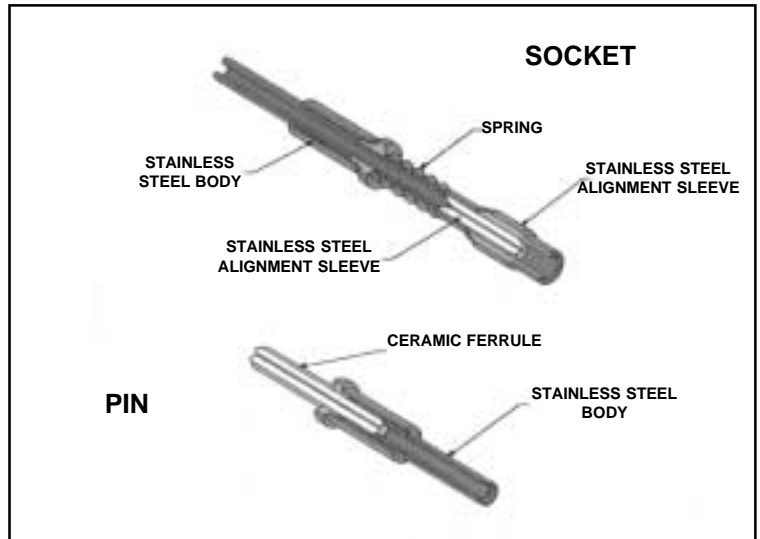

Multi-mode Size 16 Fibre Optic Termini

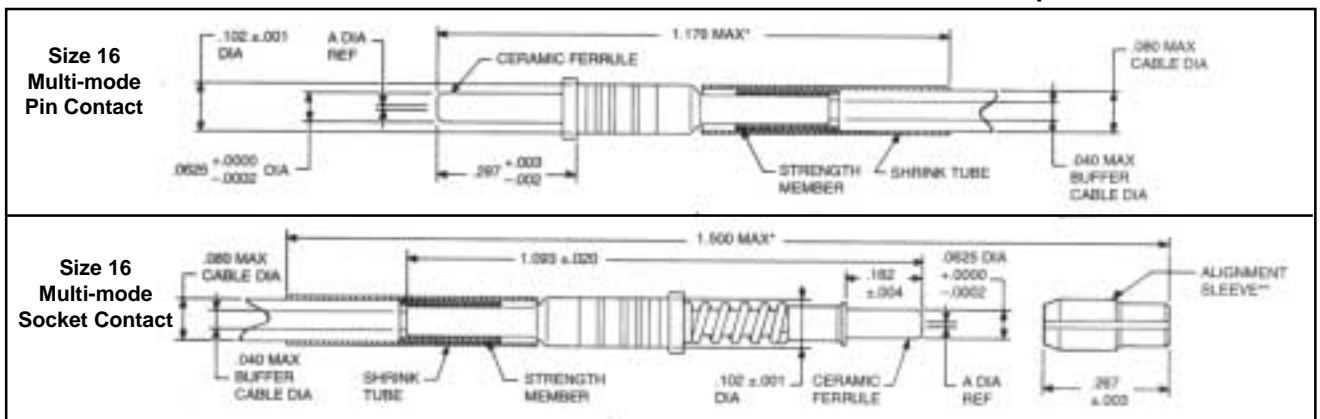

Amphenol® Multi-Channel fibre optic connectors are supplied less contacts. Order multi-mode termini by Amphenol part number designation or MIL-29504 designation as shown in the charts below.

.. Indicated dimension when fully assembled.
Alignment sleeve shipped unassembled

| Fibre Size• Core Cladding Dia (Microns) | Size 16 Socket | Size 16 Pin | A Dia Ref | |
|---|----------------|---------------|-----------|---------|
| | | | Inches | Microns |
| 50/125 | CF-198035-010 | CF-198036-010 | .0050 | 127 |
| 62.5/125 | | | | |
| 100/140 | CF-198035-017 | CF-198036-017 | .0057 | 145 |
| 100/140/172 | CF-198035-029 | CF-198036-029 | .0069 | 175 |
| 100/140/172 | CF-198035-29A | CF-198036-29A | .0068 | 173.5 |
| 200/230 | CF-198035-053 | CF-198036-053 | .0093 | 236 |
| 200/240 | CF-198035-057 | CF-198036-057 | .0097 | 245 |
| 200/280 | CF-198035-074 | CF-198036-074 | .0114 | 290 |
| 200/300 | CF-198035-080 | CF-198036-080 | .0120 | 305 |

| M29504 Part Number | | Reference Amphenol Part Number | |
|-----------------------|---------------|-----------------------------------|--------------|
| Socket | Pin | Socket | Pin |
| M29504/5-4046 | M29504/4-4040 | CF-198035-10 | CF-198036-10 |
| M29504/5-4050 | | CF-198035-17 | |
| | M29504/4-4044 | | CF-198036-17 |

• Additional sizes available upon request

Power contacts can be purchased separately.

How to order

LJT 06 RT**-11-35 S A (014)

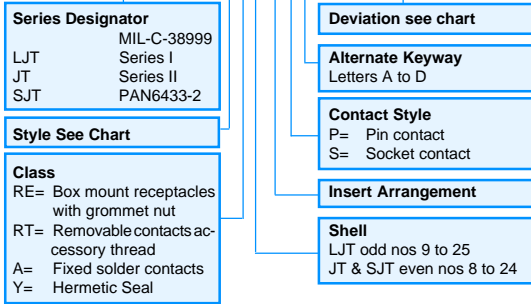

* Note: Add S to TV on F class connectors
** For Hermetic connectors drop RT and replace with Y

TV POO R W**-11-35 S A (W02)

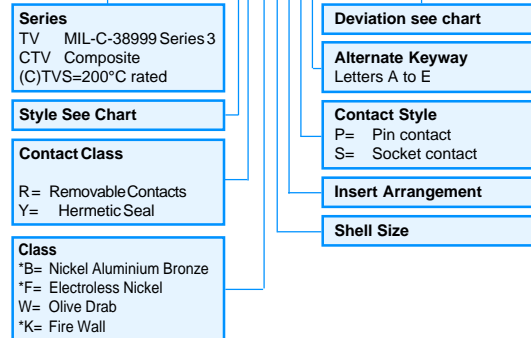

* Note: 200°C rated use "S" in part number
** For Hermetic connectors drop RW and replace with Y

MS27467 T**-11B-35 S A

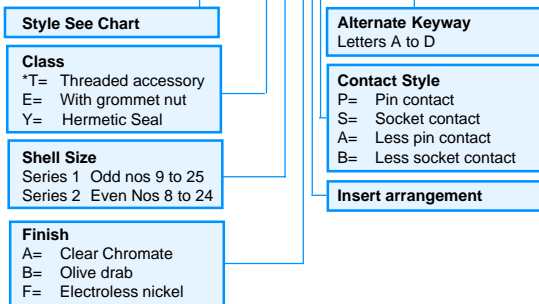

* Not available in box mount receptacle style
** For Hermetic connectors drop T and replace with Y

D38999 26 W** A 35 S A

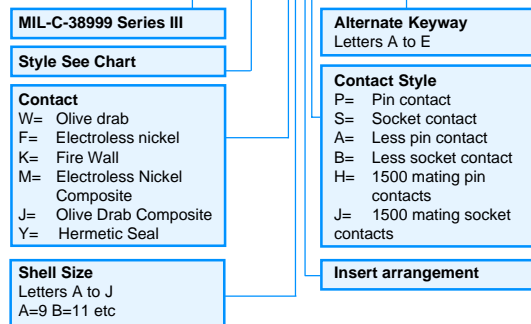

** For Hermetic connectors drop W and replace with Y

| | | | | | | | | | |
|---|----|----|----|----|----|----|----|----|---------------------|
| A | B | C | D | E | F | G | H | J | MIL Shell Size |
| 9 | 11 | 13 | 15 | 17 | 19 | 21 | 23 | 25 | AMPHENOL Shell Size |

Style Chart Series 1

| Style | LJT | MS Series 1 | BS Series | HE308 |
|----------------------------|----------|-------------|-----------|-------|
| Wall mount receptacle | 00 | 27466 | C6160 | 00 |
| Back wall mount receptacle | PQ00 | 27656 | C6163 | |
| Box mount receptacle | 02 | 27496 | C6162 | |
| Long box mount receptacle | 02 (053) | - | - | |
| Jam nut | 07 | 27468 | C6167 | 07 |
| Back box receptacle | P02 | 27505 | C6164 | |
| Grounded plug | 06 | 27467 | C6166 | 06 |
| Hermetic Rec. Wall Mount | 00 | 27469 | - | - |
| Hermetic Jam Nut Rec. | 07 | 27470 | - | - |
| Hermetic Solder Mount Rec. | 01 | 27471 | - | - |

Style Chart Series 2

| Style | JT | Pan | BS series 2 | MS series 2 | HE309 |
|----------------------------|----------|-----|-------------|-------------|-------|
| Wall mount receptacle | 00 | - | C2022 | 27472 | |
| Back wall mount receptacle | PQ00 | B | C2023 | 27497 | 03 |
| Box mount receptacle | 02 | - | C2251 | 27499 | |
| Long box mount receptacle | 02 (053) | - | C2552 | 27513 | |
| Jam nut | 07 | A | C2024 | 27474 | 07 |
| Back box receptacle | P02 | E | C2253 | 27508 | |
| Plug | 06 | F | C2020 | 27473 | 06 |
| Grounded plug | G06 | FG | C2021 | 27484 | G06 |
| Hermetic Wall Mount Rec. | 00 | - | - | 27475 | - |
| Hermetic Box Mount Rec. | 02 | - | - | 27476 | - |
| Hermetic Solder Mount Rec. | 1Y | - | - | 27478 | - |
| Hermetic Jam Nut Rec. | 07 | - | - | 27477 | - |

Style Chart Series 3

| Style | TV | D38999 | BS Series 3 | JN1034 |
|----------------------------|---------|--------|-------------|--------|
| Back wall mount receptacle | (S) P00 | 20 | C6170 | A |
| Jam nut | (S) 07 | 24 | C6177 | B |
| Back box receptacle | (S) P02 | - | - | F |
| Grounded plug | (S) 06 | 26 | C6176 | C |
| Lanyard release | FBR | 31 | - | E |
| Hermetic Box Mount Rec. | 02Y | 21 | - | - |
| Hermetic Jam Nut Rec. | 07Y | 23 | - | - |
| Hermetic Solder Mount Rec. | 1Y | 25 | - | - |

Style Chart Series SJT

| Style | SJT | PAN | JN1003 | VG96912 |
|----------------------------|-----|-----|--------|---------|
| Wall mount receptacle | 00 | - | - | - |
| Back wall mount receptacle | 00 | B | B | A |
| Box mount receptacle | 02 | - | - | - |
| Jam nut | 07 | A | - | B |
| Plug | 06 | F | - | E |
| Grounded plug | G06 | FG | FG | D |
| Hermetic Solder Mount Rec. | 1Y | - | E | C |
| Hermetic Jam Nut Rec. | 07Y | - | - | - |

PAN6433 1 F-10-35 S A

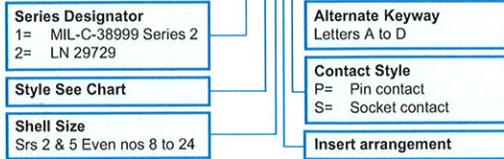

Note: All PAN6433 Connectors are olive drab plated

BS 9520G0003 C6176 NW 11 35 F N O

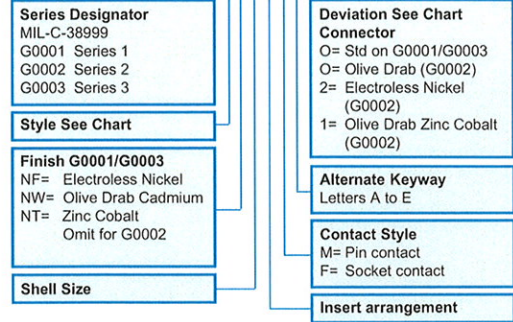

SN-WITH CONTACTS

**JN1034AXXXSNL LESS CONTACTS
JN1034A-F 10 35 SN1 - WITH CONTACTS**

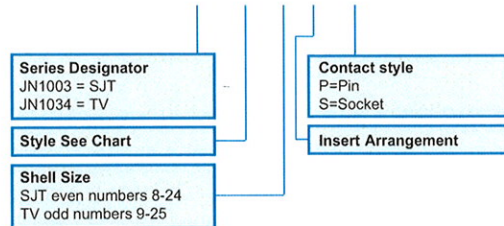

VG96912-A 10 35 S

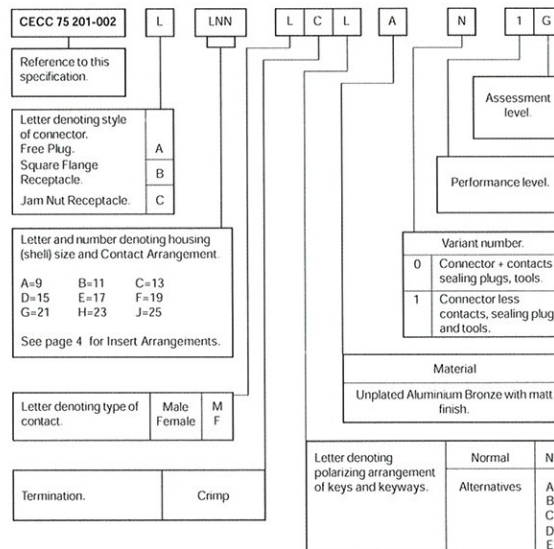
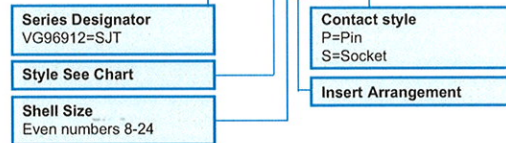

L=Letter N=Number
Eg. CECC 75 201-002 AB35 MCN AOIG
Free Plug Size 11, 13 Way, Crimp Pin Contacts, Normal Orientation, Including Contacts, Seal Plugs and Tools
Performance Level 1, Assessment Level G.

Deviation List

| LJT/JT TV/SJT | Description |
|------------------|--|
| * Blank | Clear Chromate Plating |
| *014 | Olive Drab Cadmium Over Electroless Nickel Plating |
| *023 | Electroless Nickel Plating |
| *386 | 014 + Cable Clamp |
| *424 | 023 + Cable Clamp |
| L/C | Less Contacts |
| *SR | Clear Chromate + Cable Clamp |
| W02 | Drilled & Tapped Square Flange |
| W03 | Clear Chromate + Heavy Duty Coupling Ring - LJT |
| W08 | 014 + Heavy Duty Coupling Ring + Less Contacts |
| W09 | 014 + Heavy Duty Coupling Ring |
| W12 | 023+Heavy Duty Coupling Ring - LJT |
| W14 | Snatch Plug-LJT/JT |
| W52 | Olive Drab Zinc Cobalt |

* Applicable to LJT and JT part numbers only