

REVISION Q

DO NOT SCALE FROM THIS PRINT

DIMENSIONS ARE IN INCHES		UNLESS OTHERWISE NOTED	TOLERANCES ARE:	TITLE:	DWG NO:
ONE PLACE DECIMALS $\pm .1$ [2.5]	THREE PLACE DECIMALS $\pm .005$ [13]		ANGLES $\pm 2^\circ$.8MM x 1.2MM C.L. TERMINAL STRIP ASSM	FTE-1XX-XX-G-DH-X-XX
TWO PLACE DECIMALS $\pm .01$ [3]	FOUR PLACE DECIMALS $\pm .0020$ [051]				SHEET 1 OF 2

NOTES:

1. MINIMUM PUSHOUT FORCE: .5 LB.
2. SHEAR TAILS TO DIMENSION SHOWN, .003 [08] MAX BURR.
3. .015 [38] MAX CUT FLASH; NO FLASH ALLOWED IN OR AROUND SURFACE MOUNT TAIL AREA.
4. $\text{\textcircled{C}}$ REPRESENTS A CRITICAL DIMENSION.
5. ENDWALL THICKNESS TO BE .008 [20] MIN.

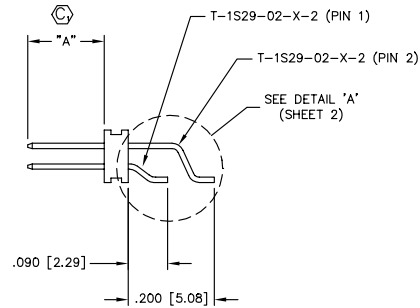
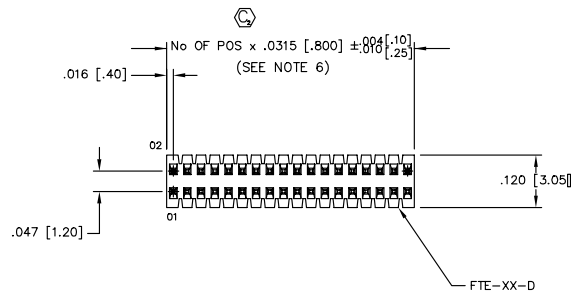
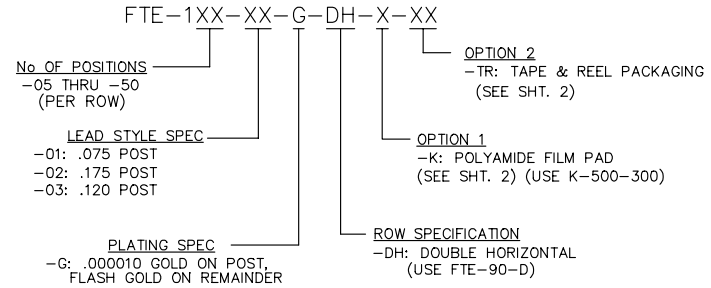
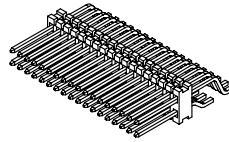

IN-PROCESS 1

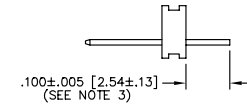

IN-PROCESS 2

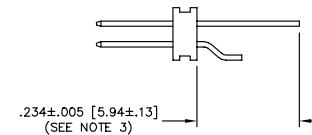

LEAD STYLE	"A"	TERMINAL
-01	.075 [1.91]	T-1S29-02-X-2
-02	.175 [4.45]	T-1S29-02-X-2
-03	.120 [3.05]	T-1S29-02-X-2

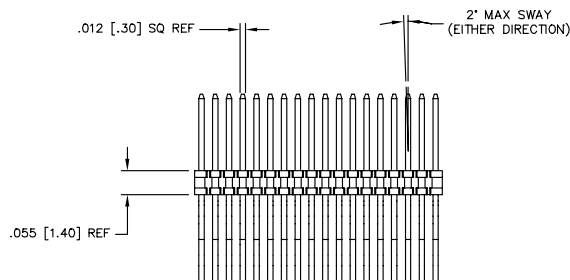

MATERIAL:
BODY: LCP
COLOR: BLACK
TERMINAL: PHOS BRONZE

MAX BOW ALLOWED TOP TO BOTTOM OR SIDE TO SIDE: .002 [05] MAX.

PLOT SCALE: .225/ DIMSCALE .150

samtec

520 PARK EAST BLVD. NEW ALBANY, INDIANA 47150
PHONE (812) 944-6733 P.O. BOX 1147
CODE 55322

MADE BY: D PURVIS 10/13/98

FTE-1XX-XX-G-DH-X-XX
SHEET 1 OF 2

PROPRIETARY NOTE
THIS DOCUMENT CONTAINS INFORMATION CONFIDENTIAL AND PROPRIETARY TO SAMTEC INC. AND SHALL NOT BE REPRODUCED OR TRANSMITTED TO OTHER DOCUMENTS OR DISCLOSED TO OTHERS OR USED FOR ANY PURPOSE OTHER THAN THAT FOR WHICH IT WAS OBTAINED WITHOUT THE EXPRESSED WRITTEN CONSENT OF SAMTEC INC.