

### 0305

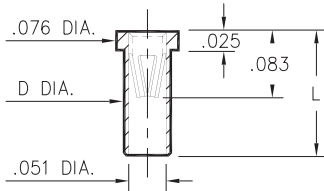

Basic Part Number	Length L	Dia. D
0305-0	.095	.056
0305-1	.105	.058
0305-2	.155	.058

**0305-X-15-XX-47-XX-10-0**  
Solder mount in .059/.061 mounting hole  
Also available on 8mm wide carrier tape: 5,500 parts per 13" reel.  
Order as: 0305-X-57-XX-47-XX-10-0

### 0279

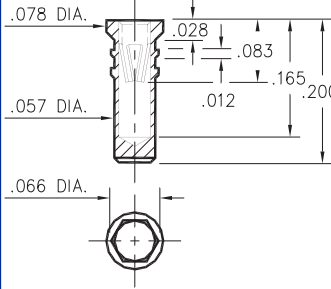

**0279-0-15-XX-47-XX-10-0**  
Hex press-fit in .062 plated thru hole

### 0330

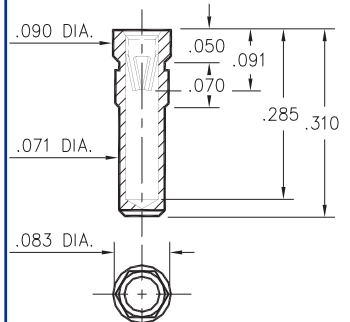

**0330-0-15-XX-47-XX-10-0**  
Hex press-fit in .079 plated thru hole

### 0300/8300

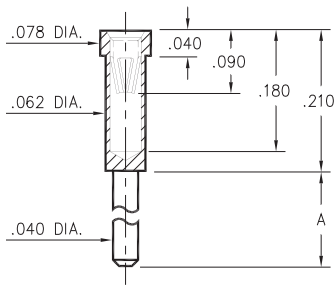

Basic Part Number	Length A
0300-1	.110
0300-2	.187
8300-0	.140

**X300-X-15-XX-47-XX-10-0**  
Solder mount in .042 min. mounting hole

### 0301

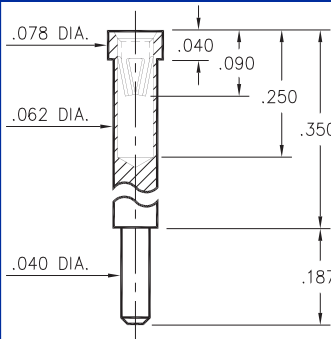

**0301-1-15-XX-47-XX-10-0**  
Solder mount in .042 min. mounting hole

### 0309

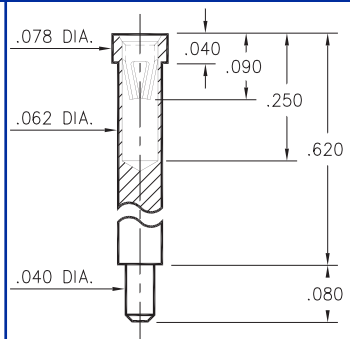

**0309-2-15-XX-47-XX-10-0**  
Solder mount in .042 min. mounting hole

### 0399

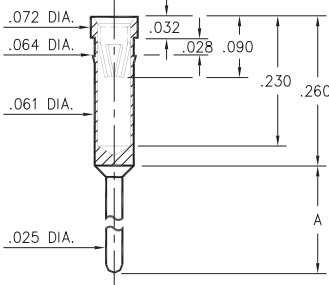

Basic Part Number	Length A
0399-0	.230
0399-1	.180

**0399-X-15-XX-47-XX-04-0**  
Press-fit in .061 mounting hole

### 1304

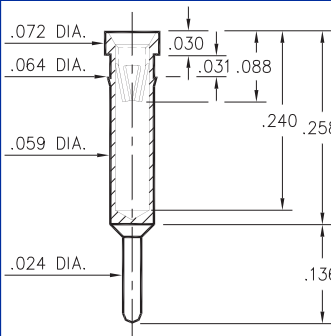

**1304-0-15-XX-47-XX-04-0**  
Press-fit in .061 mounting hole

## SPECIFICATIONS

**SHELL MATERIAL:**  
Brass Alloy 360, 1/2 Hard

**CONTACT MATERIAL:**  
Beryllium Copper Alloy 172, HT

**DIMENSION IN INCHES**  
**TOLERANCES ON:**  
LENGTHS: ±.005  
DIAMETERS: ±.002  
ANGLES: ± 2°

**ORDER CODE: XXXX - X - 15 - XX - 47 - XX - XX - 0**

**BASIC PART #**

**SPECIFY SHELL FINISH:**  
01 200µ" TIN/LEAD OVER NICKEL  
◇ 80 200µ" TIN OVER NICKEL (RoHS)  
◇ 15 10µ" GOLD OVER NICKEL (RoHS)

**SPECIFY CONTACT FINISH:**  
01 200µ" TIN/LEAD OVER NICKEL  
◇ 80 200µ" TIN OVER NICKEL (RoHS)  
◇ 27 30µ" GOLD OVER NICKEL (RoHS)



**CONTACT**

#47 CONTACT (DATA ON PAGE 221)