

## VS-09-SET-EMV

Order No.: 1689158

<http://eshop.phoenixcontact.de/phoenix/treeViewClick.do?UID=1689158>

D-SUB connector set, shell size 1, IP67 protection, with shrouds



### Commercial data

EAN	4017918890568
Pack	1 pcs.
Customs tariff	85366990
Weight/Piece	0.0781 KG
Catalog page information	Page 264 (PC-2009)

### Product notes

WEEE/RoHS-compliant since:  
06/02/2006

<http://www.download.phoenixcontact.com>  
Please note that the data given here has been taken from the online catalog. For comprehensive information and data, please refer to the user documentation. The General Terms and Conditions of Use apply to Internet downloads.

### Technical data

#### Mechanical characteristics

Shielded	Yes
Insertion/withdrawal cycles	≥ 1000
External cable diameter	3 mm ... 9 mm
Cable exit	Angled

Color	gray
Ambient temperature (operation)	-40 °C ... 80 °C

**Material data**

Inflammability class acc. to UL 94	V0
Housing material	PA
Sealing material	Flat gasket: NBR; profile gasket: EPDM
Seal material	Flat gasket: NBR; profile gasket: EPDM
Cable seal material	CR/NBR
Degree of protection	IP67

**Diagrams/Drawings**

Dimensioned drawing

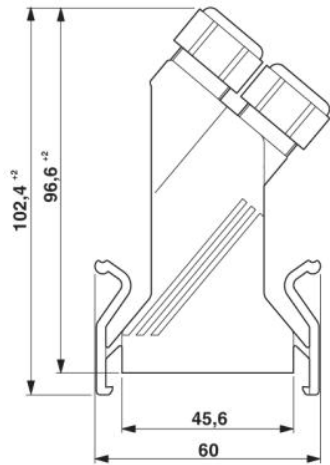

D-SUB sleeve housings

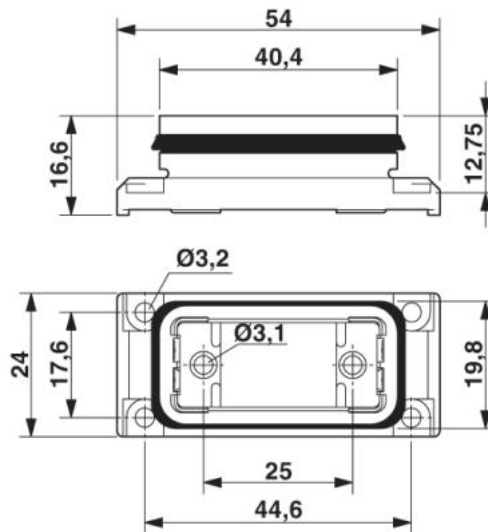

D-SUB panel mounting frame

Panel cutout

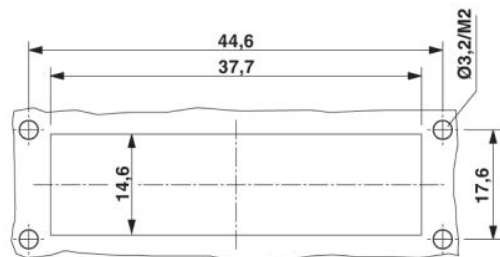

**Address**

PHOENIX CONTACT Inc., USA  
586 Fulling Mill Road  
Middletown, PA 17057, USA  
Phone (800) 888-7388  
Fax (717) 944-1625  
<http://www.phoenixcon.com>



© 2010 Phoenix Contact  
Technical modifications reserved;