

DESCRIPTION: MALE - 0.283 RIGHT ANGLE / MACHINED

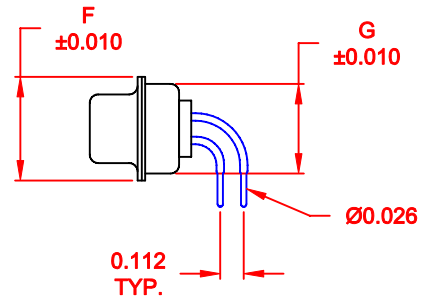
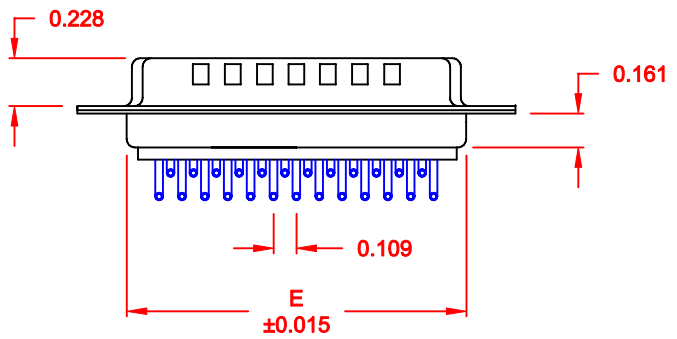
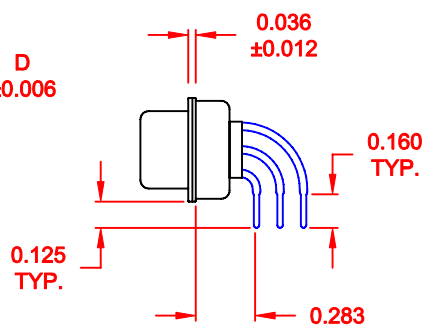
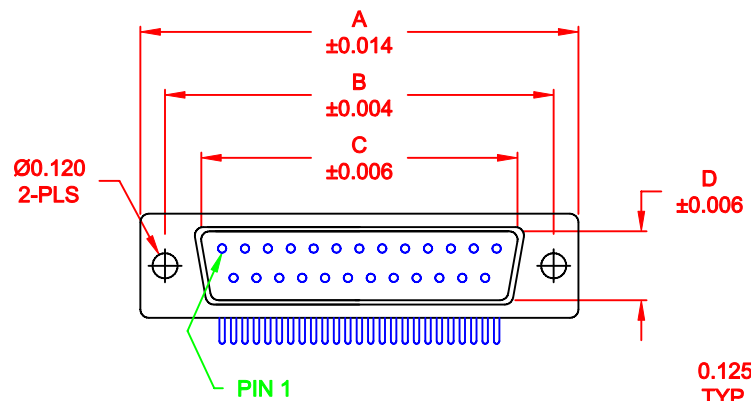

No. OF PINS	DIMENSIONS						
	A	B	C	D	E	F	G
9	1.213	0.984	0.669	0.331	0.760	0.480	0.429
	30.80	24.99	17.00	8.40	19.30	12.20	10.90
15	1.541	1.312	0.996	0.331	1.083	0.480	0.429
	39.15	33.32	25.30	8.40	27.51	12.20	10.90
25	2.088	1.852	1.535	0.331	1.630	0.480	0.429
	53.04	47.04	39.00	8.40	41.40	12.20	10.90
37	2.729	2.500	2.181	0.331	2.276	0.480	0.429
	69.32	63.50	55.40	8.40	57.81	12.20	10.90
50	2.635	2.406	2.079	0.437	2.182	0.598	0.535
	66.93	61.11	52.80	11.10	55.42	15.20	13.60

173-YYY-112RYY1

- SERIES _____
- POSITIONS _____
- 009 _____
- 015 _____
- 025 _____
- 037 _____
- 050 _____
- GENDER _____
- 1 = MALE
- 2 = FEMALE
- TERMINATION _____
- 1 = PC MOUNTING
- SHELL PLATING _____
- 2 = TIN (GROUND INDENTS)
- RoHS COMPLIANT _____
- HARDWARE OPTIONS _____
- 00 = NO HARDWARE
- 14 = SHORT BRACKET WITH 4-40 SCREW LOCK
- 24 = SHORT BRACKET WITH 4-40 SCREW
- PLATING OPTIONS _____
- 1 = GOLD FLASH
- 2 = 30MICRO-INCH GOLD

MATERIAL:

SHELL: STEEL, TIN PLATED
 INSULATOR: UL 94V-O RATED, BEIGE PBTP
 PROCESS TEMP.: 260° PROCESS TEMPERATURE
 CONTACT: BRASS

ELECTRICAL:

CURRENT RATING: 5 AMPS
 CONTACT RESISTANCE: 15 mOhms Max.
 INSULATION RESISTANCE: 1,000 MOhms min.
 VOLTAGE: 500VAC FOR 1 MINUTE
 TEMPERATURE: -50° C TO 100° C

DO NOT SCALE FROM DRAWING

RoHS COMPLIANT

	THESE DRAWINGS AND SPECIFICATIONS ARE THE PROPERTY OF NorComp AND SHALL NOT BE REPRODUCED, COPIED OR USED AS THE BASIS FOR THE MANUFACTURE OF SALE OF APPARATUS WITHOUT WRITTEN PERMISSION.		DRAWN: WAYNE ROBBINS	DATE: 09-16-05
			CHECKED:	DATE:
NorComp		SCALE: 1:1	SHEET 1 OF 3	REV 4
		DWG NO. 173-YYY-112RYY1		

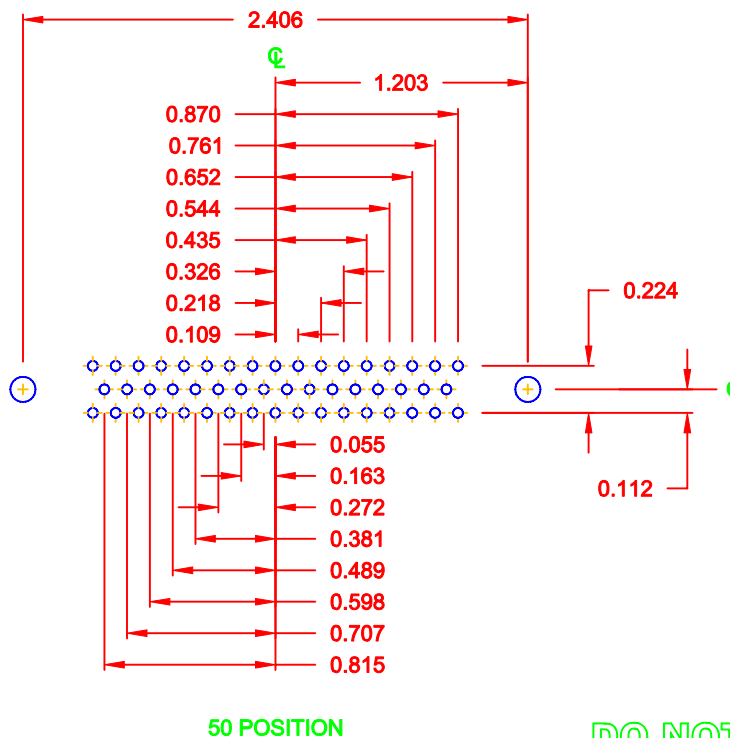
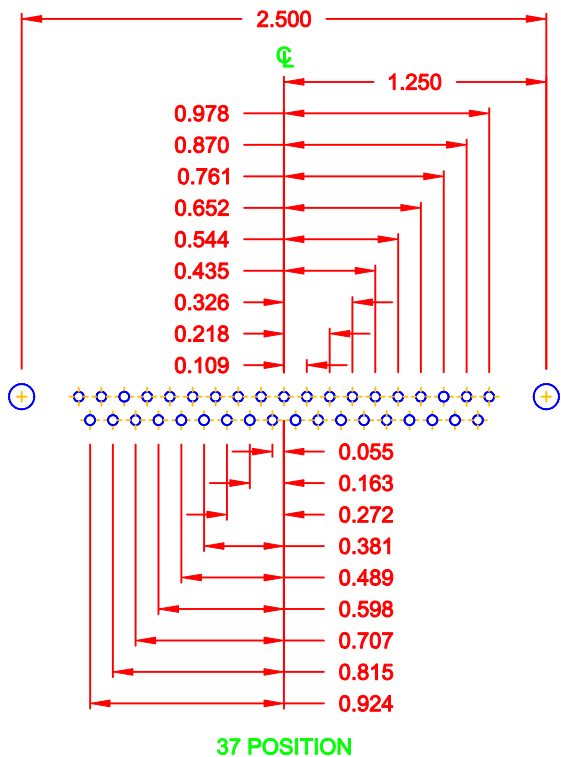
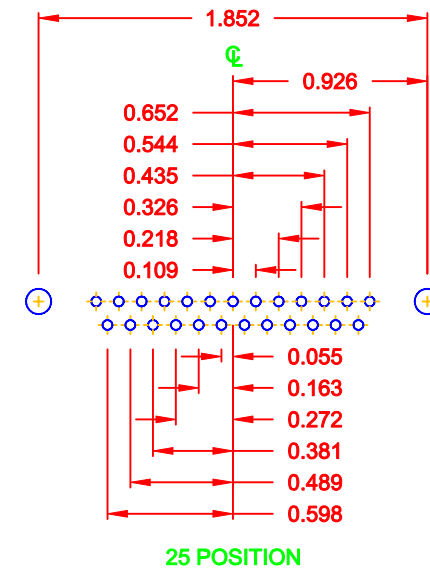
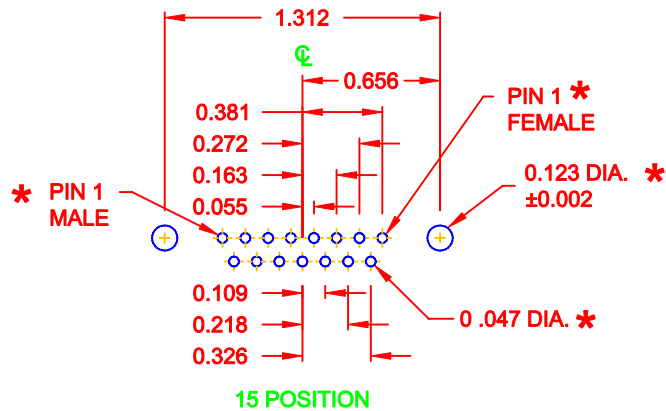
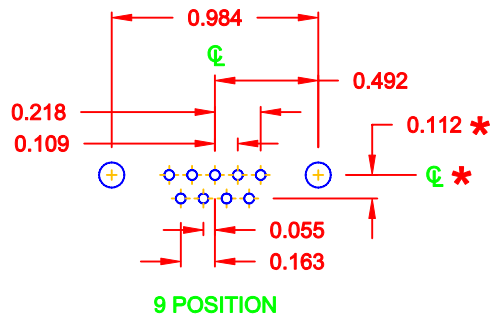

* TYP. ON ALL SIZES
UNLESS NOTED OTHERWISE

DO NOT SCALE FROM DRAWING

	THESE DRAWINGS AND SPECIFICATIONS ARE THE PROPERTY OF NorComp AND SHALL NOT BE REPRODUCED, COPIED OR USED AS THE BASIS FOR THE MANUFACTURE OF SALE OF APPARATUS WITHOUT WRITTEN PERMISSION.		DRAWN: C. SMITH	DATE: 03-08-06
			CHECKED:	DATE:
NorComp		SCALE: FULL	SHEET 2 OF 3	REV 4
		DWG NO. 173-YYY-112RYY1		

HARDWARE OPTIONS

REPLACE -YY IN LAST 3 DIGITS WITH OPTION CHOSEN

173/174 SERIES

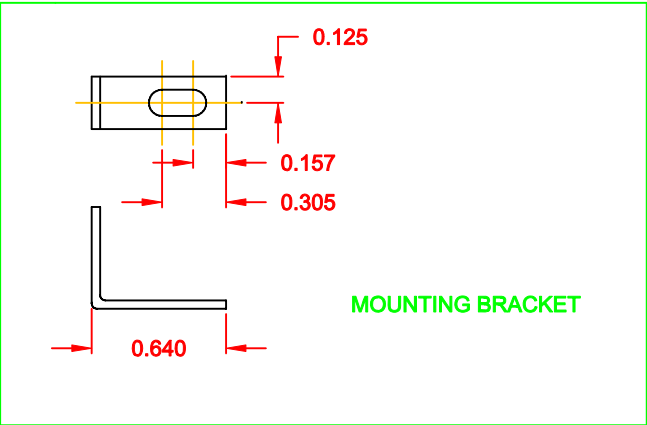

173 / 174 SERIES

- 14Y = SHORT BRACKET & 4-40 FEMALE HEX SOCKET
- 24Y = SHORT BRACKET & 4-40 SCREW

175/176 SERIES

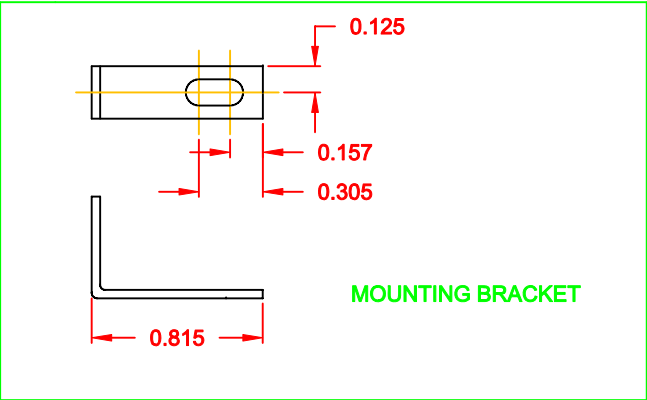

176 / 176 SERIES

- 15Y = LONG BRACKET & 4-40 FEMALE HEX SOCKET
- 25Y = SHORT BRACKET & 4-40 SCREW

MATERIAL: COLD ROLLED STEEL

PLATING: CLEAR ZINC

RoHS COMPLIANT

DO NOT SCALE FROM DRAWING

	THESE DRAWINGS AND SPECIFICATIONS ARE THE PROPERTY OF NorComp AND SHALL NOT BE REPRODUCED, COPIED OR USED AS THE BASIS FOR THE MANUFACTURE OF SALE OF APPARATUS WITHOUT WRITTEN PERMISSION.		DRAWN: PAM JENKINS	DATE: 11-28-05
			CHECKED:	DATE:
NorComp		SCALE:	SHEET 3 OF 3	REV 4
		DWG NO. 173-YYY-112RYY1		