

- 1. SEE SHEET 2 FOR RECOMMENDED P.C. BOARD LAYOUT. TRUE POSITION TOLERANCE FOR P.C. BOARD LAYOUT IS .010 [0.25] AT MAX MATERIAL CONDITION. SUGGESTED BOARD THICKNESS IS .062 [1.57]
- 2. THE CONNECTORS DESCRIBED IN THIS DOCUMENT MEET THE REQUIREMENTS OF MIL-C-24308 AND MATE WITH ANY PLUG CONNECTOR WITH SAME INSERT ARRANGEMENT.
- 3. MARKED WITH .047 [1.19]-.062 [1.57] HIGH CHARACTERS. FAR SIDE REFERS TO THE WIDE SIDE OF THE KEYSTONE. NEAR SIDE REFERS TO THE NARROW SIDE OF THE KEYSTONE. IF THE REAR SHELL IS TOO SMALL FOR THE ENTIRE MILITARY PART NUMBER, MARKING SHALL BE LOCATED AS FOLLOWS:
 - A. "M24308" ON FRONT SHELL, FAR SIDE.
 - B. SLASH SHEET AND DASH NUMBER ON REAR SHELL, FAR SIDE.
 - C. "AMP" AND DATE CODE ON FRONT SHELL, NEAR SIDE.
 - D. MFG'S PART NUMBER ON REAR SHELL, NEAR SIDE.
- IF THE FRONT SHELL IS TOO SMALL FOR "AMP", MFG'S PART NUMBER AND DATE CODE, MARKING SHALL BE SPLIT AS FOLLOWS:
 - A. MFG'S PART NUMBER ON REAR SHELL, NEAR SIDE.
 - B. "AMP" AND DATE CODE ON FRONT SHELL, NEAR SIDE.
 - C. MILITARY PART NUMBER ON REAR SHELL, FAR SIDE.
- 4. POINT OF ELECTRICAL ENGAGEMENT - AS MEASURED WITH A .0390-.0393 (0.991-0.998) DIA SQUARE ENDED PIN.
- 5. SOLDER DIPPED PER J-STD-001 WITH Sn63 SOLDER PER J-STD-006 IN THE ENTIRE AREA OF DIMENSION SHOWN. (1757828-6 THRU -10 ONLY.)
- 6. MEETS SOLDERABILITY PER MIL-STD-202 METHOD 208.
- 7. SPACERS (QTY = 2) ARE SUPPLIED WITH CONNECTOR; NOT ATTACHED.

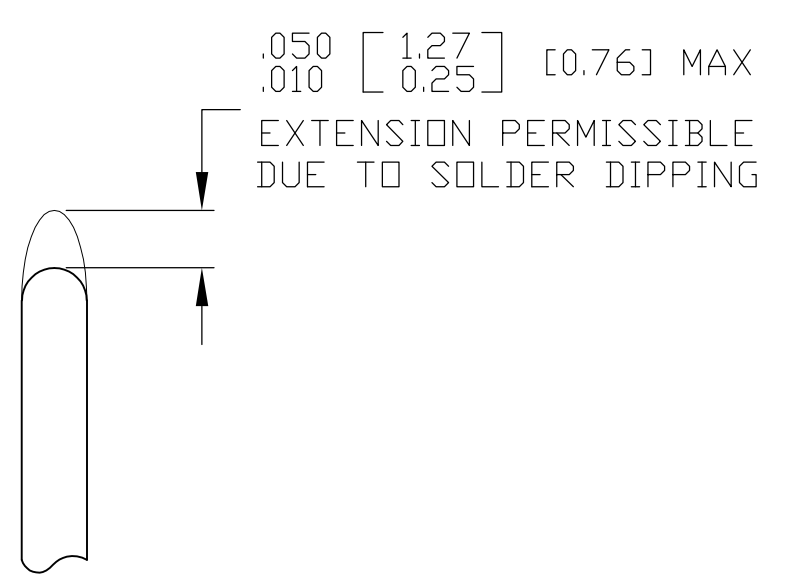
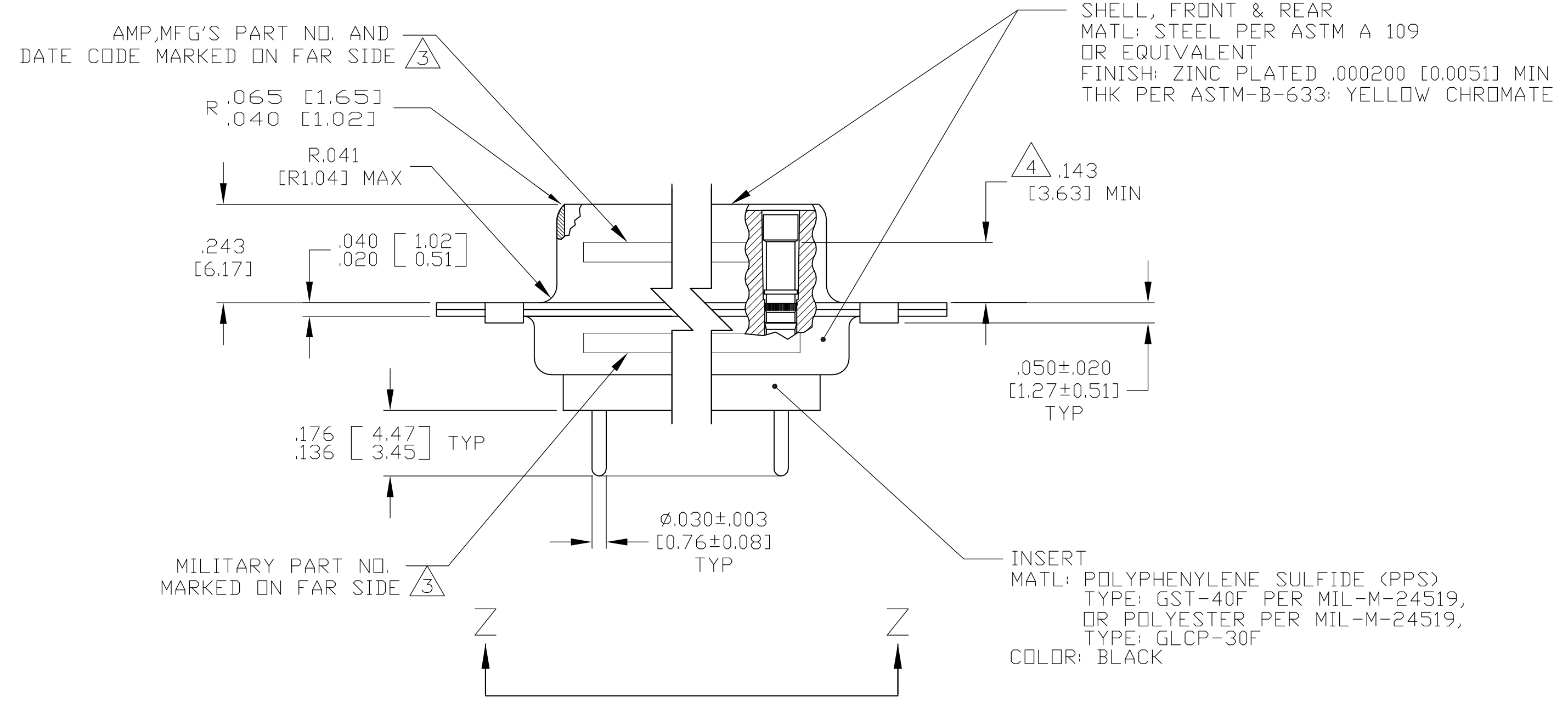

.544 [13.82]	2.188 [55.58]	.620 [15.75]	.428 [10.87]	2.411 [61.24]	2.069 [52.55]	2.650 [67.31]
.524 [13.31]	2.168 [55.07]	.590 [14.99]	.418 [10.62]	2.401 [60.99]	2.059 [52.30]	2.620 [66.55]
.432 [10.97]	2.282 [57.96]	.509 [12.93]	.316 [8.03]	2.505 [63.63]	2.164 [54.97]	2.744 [69.70]
.412 [10.46]	2.262 [57.45]	.479 [12.17]	.306 [7.77]	2.495 [63.37]	2.154 [54.71]	2.714 [68.94]
.432 [10.97]	1.635 [41.53]	.509 [12.93]	.316 [8.03]	1.857 [47.17]	1.516 [38.51]	2.103 [53.42]
.412 [10.46]	1.615 [41.02]	.479 [12.17]	.306 [7.77]	1.847 [46.91]	1.506 [38.25]	2.073 [52.65]
.432 [10.97]	1.093 [27.76]	.509 [12.93]	.316 [8.03]	1.317 [33.45]	.976 [24.79]	1.556 [39.52]
.412 [10.46]	1.073 [27.25]	.479 [12.17]	.306 [7.77]	1.307 [33.20]	.966 [24.54]	1.526 [38.76]
.432 [10.97]	.769 [19.53]	.509 [12.93]	.316 [8.03]	.989 [25.12]	.648 [16.46]	1.228 [31.19]
.412 [10.46]	.749 [19.02]	.479 [12.17]	.306 [7.77]	.979 [24.87]	.638 [16.21]	1.198 [30.43]
.544 [13.82]	2.188 [55.58]	.620 [15.75]	.428 [10.87]	2.411 [61.24]	2.069 [52.55]	2.650 [67.31]
.524 [13.31]	2.168 [55.07]	.590 [14.99]	.418 [10.62]	2.401 [60.99]	2.059 [52.30]	2.620 [66.55]
.432 [10.97]	2.282 [57.96]	.509 [12.93]	.316 [8.03]	2.505 [63.63]	2.164 [54.97]	2.744 [69.70]
.412 [10.46]	2.262 [57.45]	.479 [12.17]	.306 [7.77]	2.495 [63.37]	2.154 [54.71]	2.714 [68.94]
.432 [10.97]	1.635 [41.53]	.509 [12.93]	.316 [8.03]	1.857 [47.17]	1.516 [38.51]	2.103 [53.42]
.412 [10.46]	1.615 [41.02]	.479 [12.17]	.306 [7.77]	1.847 [46.91]	1.506 [38.25]	2.073 [52.65]
.432 [10.97]	1.093 [27.76]	.509 [12.93]	.316 [8.03]	1.317 [33.45]	.976 [24.79]	1.556 [39.52]
.412 [10.46]	1.073 [27.25]	.479 [12.17]	.306 [7.77]	1.307 [33.20]	.966 [24.54]	1.526 [38.76]
.432 [10.97]	.769 [19.53]	.509 [12.93]	.316 [8.03]	.989 [25.12]	.648 [16.46]	1.228 [31.19]
.412 [10.46]	.749 [19.02]	.479 [12.17]	.306 [7.77]	.979 [24.87]	.638 [16.21]	1.198 [30.43]

DIM J	DIM H	DIM E	DIM D	DIM C	DIM B	DIM A	INSERT ARRANGEMENT	NO OF POS	SHELL SIZE	MILITARY P/N ON CONNECTOR	MFG'S P/N MARKED ON CONNECTOR	PART NO.
-------	-------	-------	-------	-------	-------	-------	--------------------	-----------	------------	---------------------------	-------------------------------	----------

DETAIL K
SCALE 10:1
FOR 1757828-6 THRU -10 ONLY

THIS DRAWING IS A CONTROLLED DOCUMENT.

DIMENSIONS: INCHES	TOLERANCES UNLESS OTHERWISE SPECIFIED:	DRAWN: C.C. THOMAS 3-22-06	CHK: D. MILLER 3-27-06	APPRO: D. MILLER 3-27-06	NAME: D. MILLER	RECEIPTACLE ASSEMBLY, AMPLIMITE, POSTED SERIES 109, SIZE 1 THRU 5
MATERIAL: SEE CALLOUTS	FINISH: SEE CALLOUTS	WEIGHT: -	SIZE: A1	DWG CODE: 00779	DRAWING NO: 1757828	RESTRICTED TO: -
CUSTOMER DRAWING			SCALE: 4:1	SHEET: 1 OF 2	REV: B	

Tyco Electronics Corporation
Harrisburg, PA 17105-3608

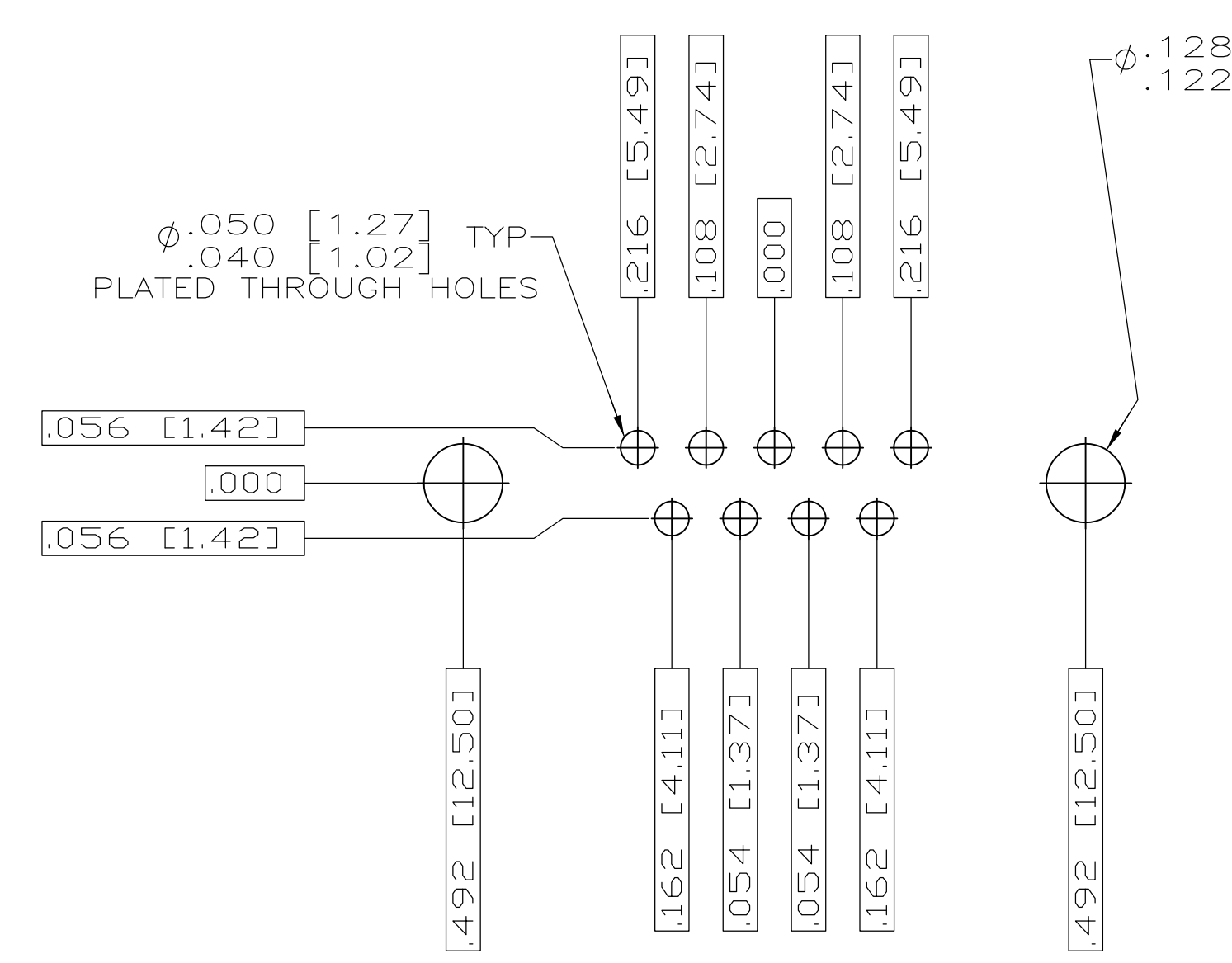

RECOMMENDED P.C. BOARD LAYOUT
 SHELL SIZE 1 (9 POSITION) ⚠

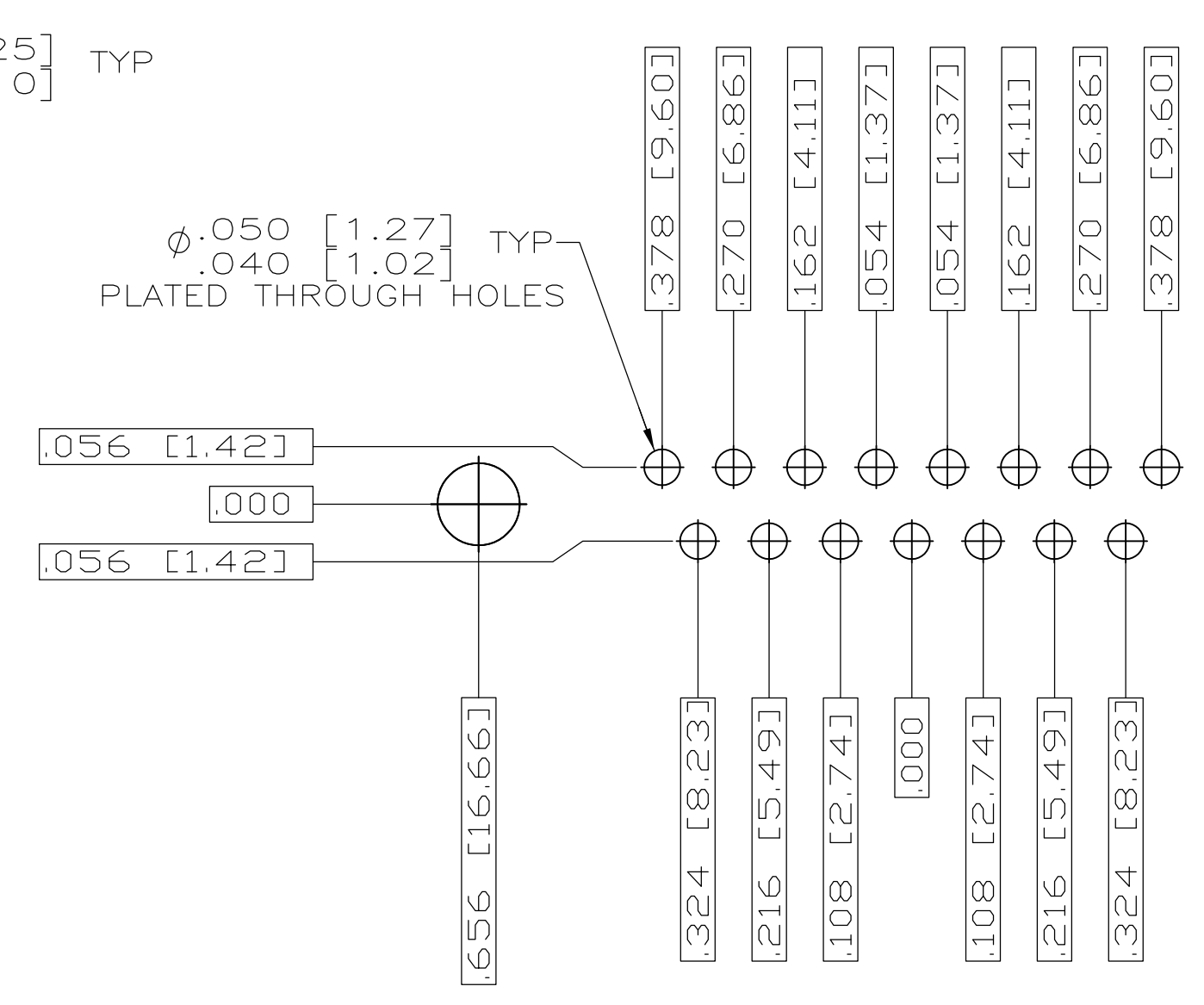

RECOMMENDED P.C. BOARD LAYOUT
 SHELL SIZE 2 (15 POSITION) ⚠

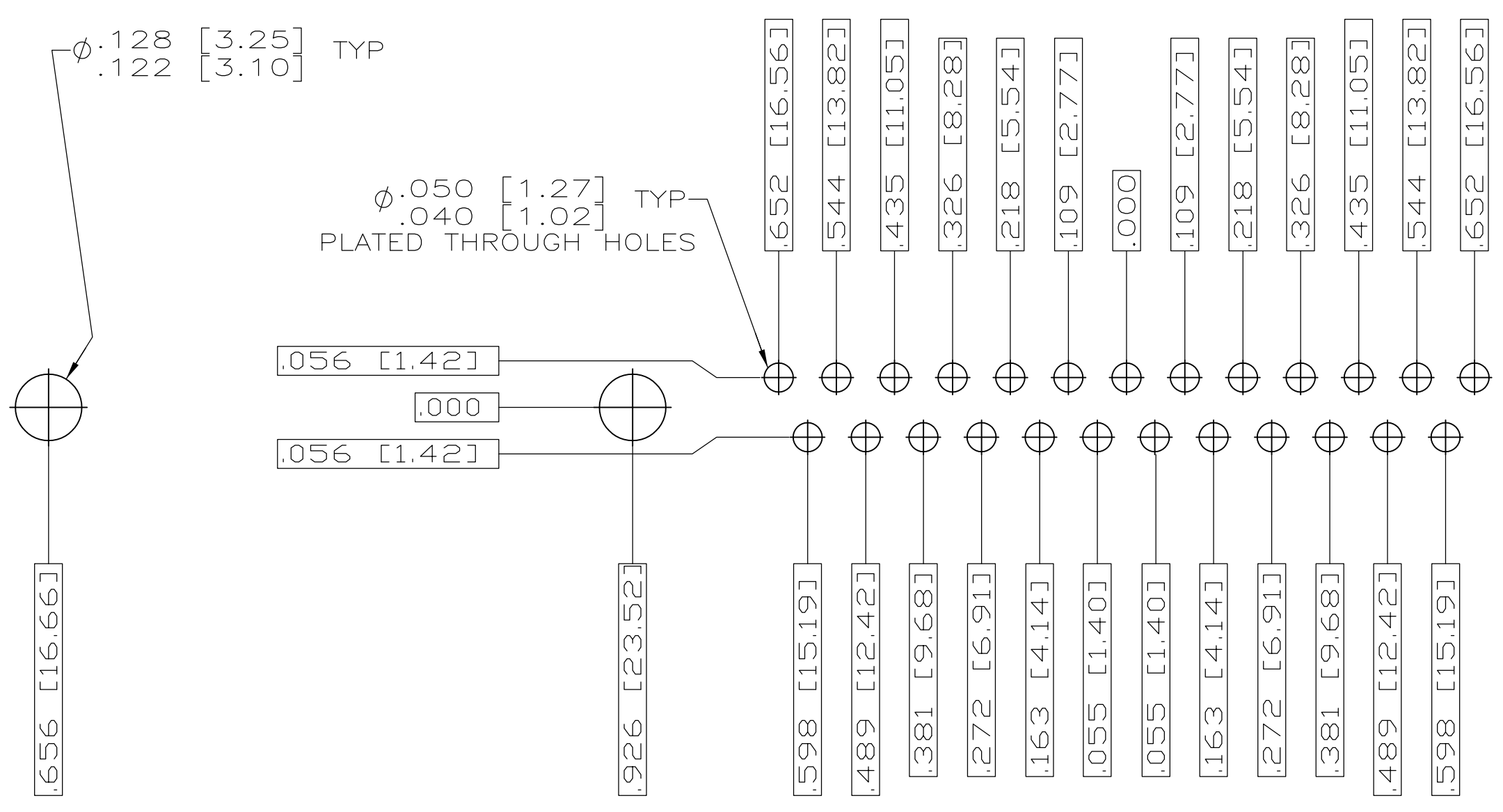

RECOMMENDED P.C. BOARD LAYOUT
 SHELL SIZE 3 (25 POSITION) ⚠

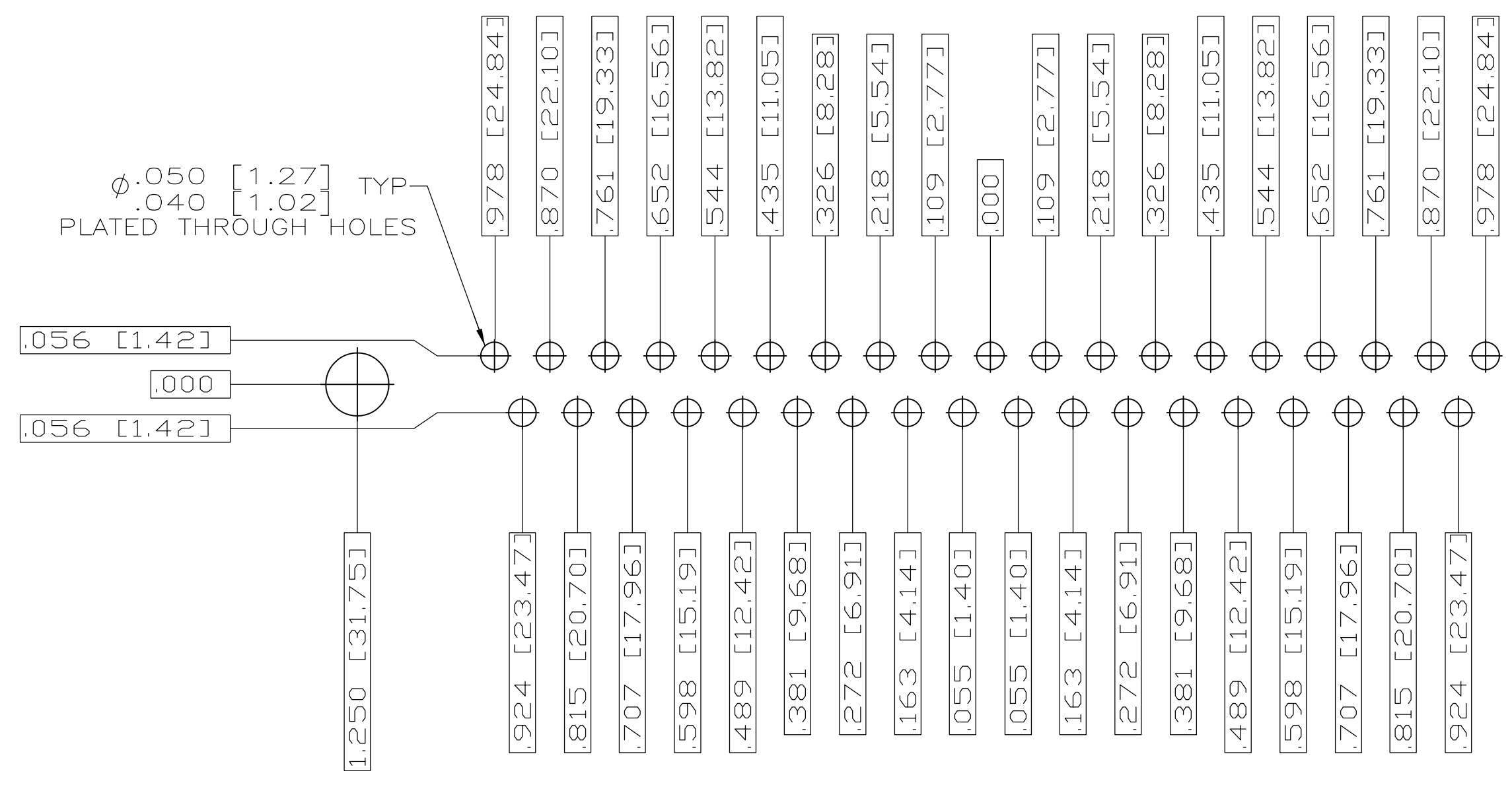

RECOMMENDED P.C. BOARD LAYOUT
 SHELL SIZE 4 (37 POSITION) ⚠

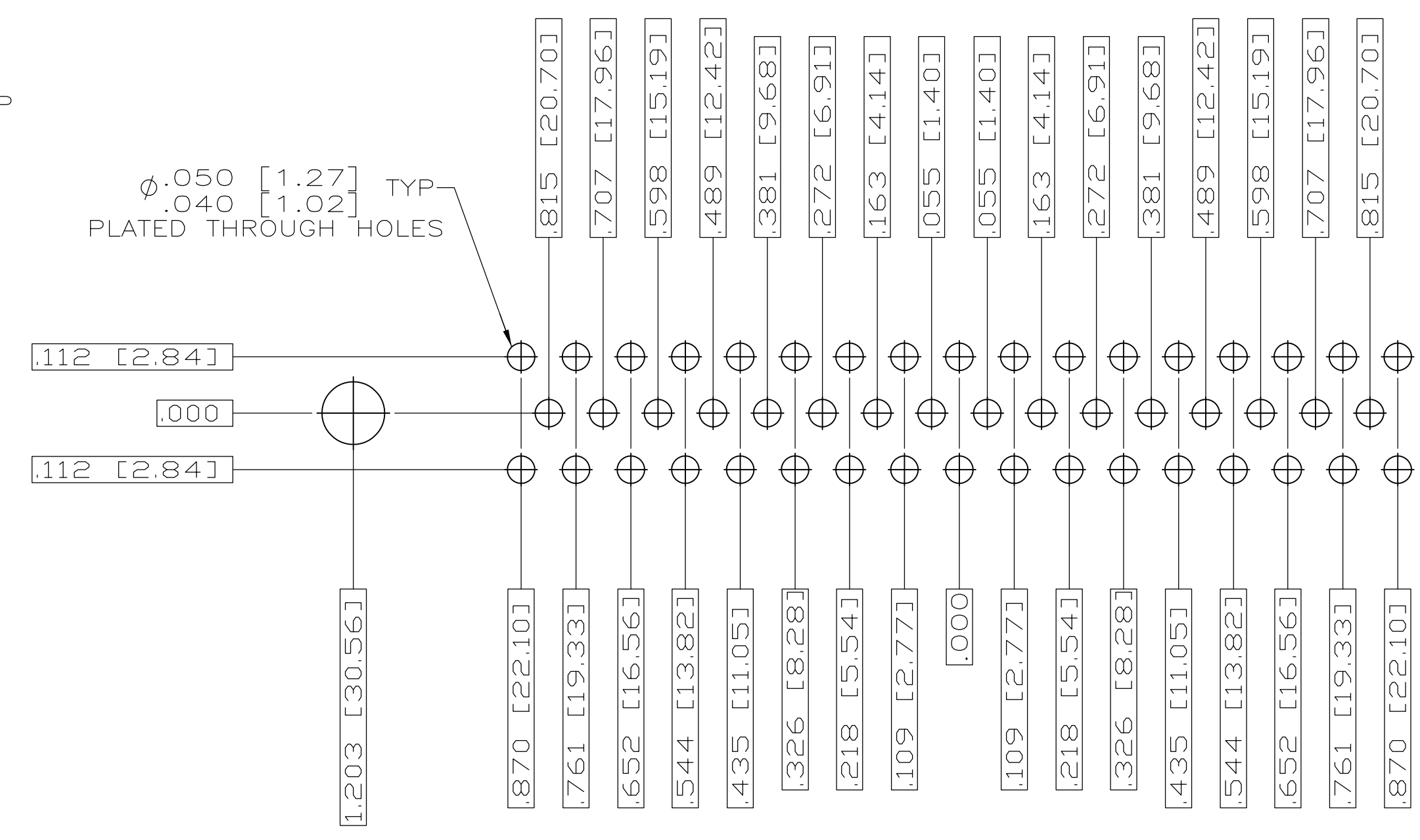

RECOMMENDED P.C. BOARD LAYOUT
 SHELL SIZE 5 (50 POSITION) ⚠

THIS DRAWING IS A CONTROLLED DOCUMENT.		DWN C.C.THOMAS 3-27-06	Tyco Electronics Corporation Harrisburg, PA 17105-3608
DIMENSIONS: INCHES		CHK D.MILLER 3-28-06	
	TOLERANCES UNLESS OTHERWISE SPECIFIED:	APR D.MILLER 3-28-06	NAME
	0 PL ± .01 1 PL ± .01 2 PL ± .01 3 PL ± .01 4 PL ± .01 ANGLES ± .5° FINISH SEE CALLOUTS	PRODUCT SPEC	RECEPTACLE ASSEMBLY,AMPLIMITE SERIES 109,SIZE 1 THRU 5
MATERIAL SEE CALLOUTS	APPLICATION SPEC	SIZE A1	RESTRICTED TO
	WEIGHT	CAGE CODE 00779	DRAWING NO 1757828
	CUSTOMER DRAWING	SCALE 4:1	SHEET 2 OF 2