

MATERIALS AND FINISH:

SHELL: STEEL MATERIAL, NICKEL FINISH
 INSULATOR: PA6T = 260°C, UL 94V-0 RATED, BLACK
 CONTACT MATERIAL: BRASS
 CONTACT FINISH: FULL GOLD FLASH

ELECTRICAL:

CONTACT CURRENT RATING: 5 AMPS
 CONTACT RESISTANCE: 30 Milliohms Max.
 DIELECTRIC WITHSTANDING VOLTAGE: 1,00VAC Min.
 INSULATION RESISTANCE: 5,000 Megohms Min.
 TEMPERATURE RATING: -55° ~ +105° C

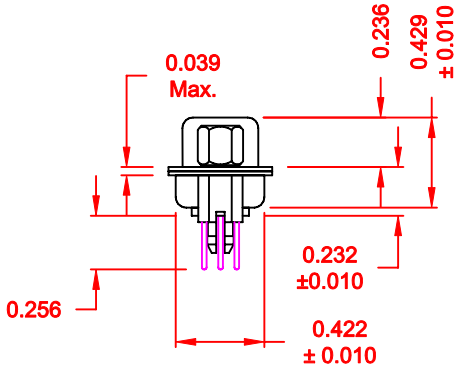
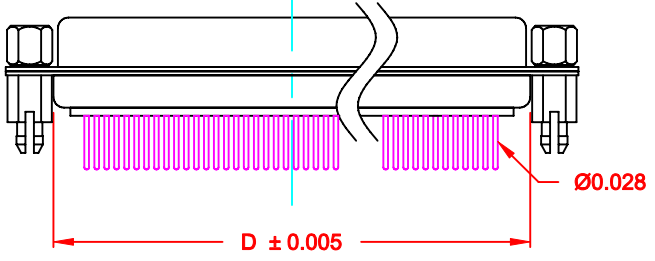
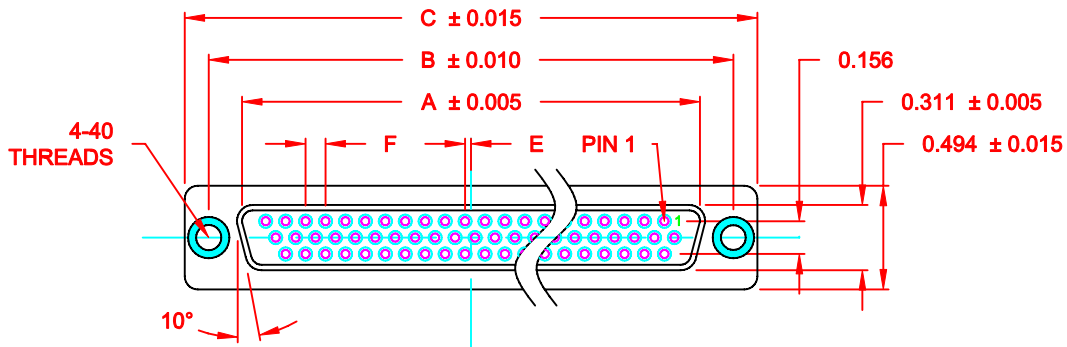

180-MYY-21YRYYY

SERIES _____
 MACHINED CONTACTS _____
 POSITION _____
 15 _____
 26 _____
 44 _____
 62 _____
 GENDER _____
 2 = FEMALE _____
 TERMINATION _____
 1 = VERTICAL DIP _____
 SHELL PLATING _____
 3 = NICKEL _____
 RoHS (HIGH TEMP.) 260° PROCESS _____
 HARDWARE _____
 00 = Ø 0.120" HOLE _____
 01 = 0.098" 4-40 INSERT, BOARD SIDE _____
 02 = 0.250" 4-40 INSERT, BOARD SIDE _____
 03 = 0.250" 4-40 INSERT, MATING SIDE _____
 05 = 0.224" BOARD LOCK, BOARD SIDE _____
 91 = 0.224" BOARD LOCK, BOARD SIDE _____
 0.189" SCREW LOCK, MATING SIDE _____
 CONTACT PLATING _____
 1 = GOLD FLASH, ENTIRE CONTACT _____
 2 = 30u" GOLD, ENTIRE CONTACT _____

DIMENSIONS (IN.)

No. OF PINS	A	B	C	D	E	F
15	0.643	0.984	1.213	0.759	0.010	0.090
25	0.971	1.312	1.541	1.083	0.020	0.090
44	1.511	1.852	2.088	1.625	0.020	0.090
62	2.159	2.500	2.729	2.272	0.023	0.094

DO NOT SCALE FROM DRAWING

	THESE DRAWINGS AND SPECIFICATIONS ARE THE PROPERTY OF NorComp AND SHALL NOT BE REPRODUCED, COPIED OR USED AS THE BASIS FOR THE MANUFACTURE OF SALE OF APPARATUS WITHOUT WRITTEN PERMISSION.		DRAWN: C. SMITH	DATE: 03-16-07
			CHECKED:	DATE:
NorComp	SCALE: 1 : 1	SHEET 1	OF 3	REV 2
	DWG NO. 180-MYY-21YRYYY			

RoHS COMPLIANT

TOLERANCE:
ALL DIMENSIONS ARE ±0.010

ALL CLINCH-NUTS ARE 4-40 INTERNAL THREADS

05X 0.224" BOARD SIDE - CN10

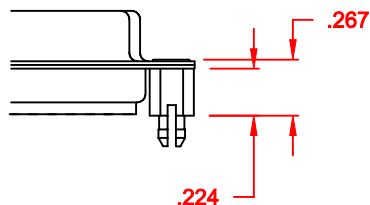

91X 0.224" BOARD SIDE
0.189 MATING SIDE
CN10/SFSO4404

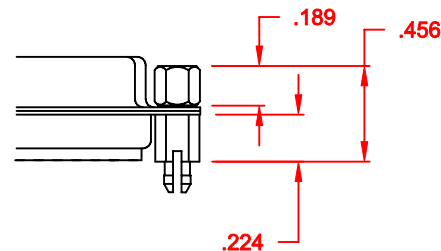

NOTE: 4-40 FEMALE SCREW LOCK IS REMOVABLE

01X 0.098" (BOARD SIDE) - CN1

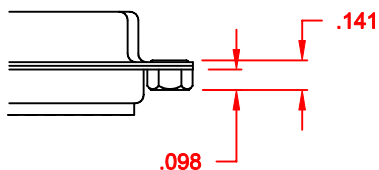

02X 0.250" (BOARD SIDE) - CN2

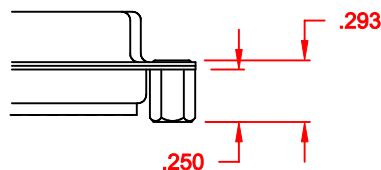

03X..... 0.250" (MATING SIDE) - CN8

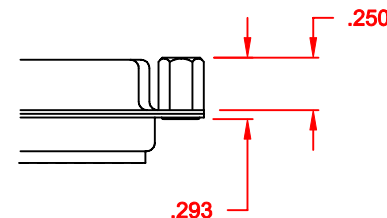

DO NOT SCALE FROM DRAWING

RoHS COMPLIANT

	THESE DRAWINGS AND SPECIFICATIONS ARE THE PROPERTY OF NorComp AND SHALL NOT BE REPRODUCED, COPIED OR USED AS THE BASIS FOR THE MANUFACTURE OF SALE OF APPARATUS WITHOUT WRITTEN PERMISSION.		DRAWN: C. SMITH	DATE: 02-12-08
			CHECKED:	DATE:
NorComp		SCALE:	SHEET 2 OF 3	REV 2
		DWG NO. 180-MYY-21YRYYY		

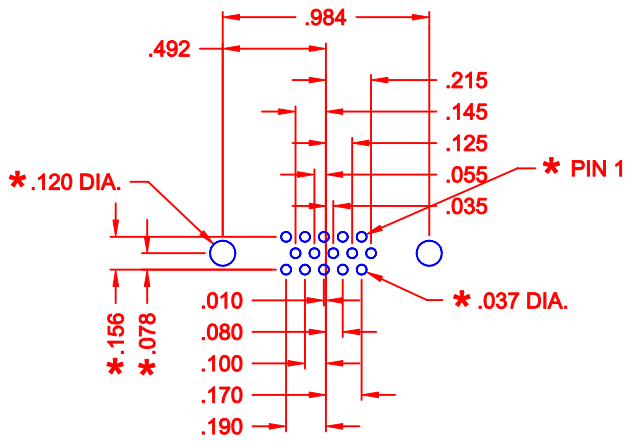

15 POSITION

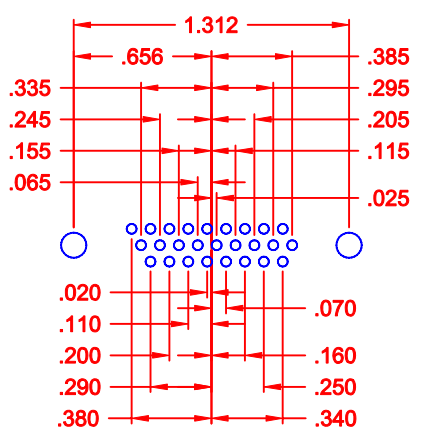

26 POSITION

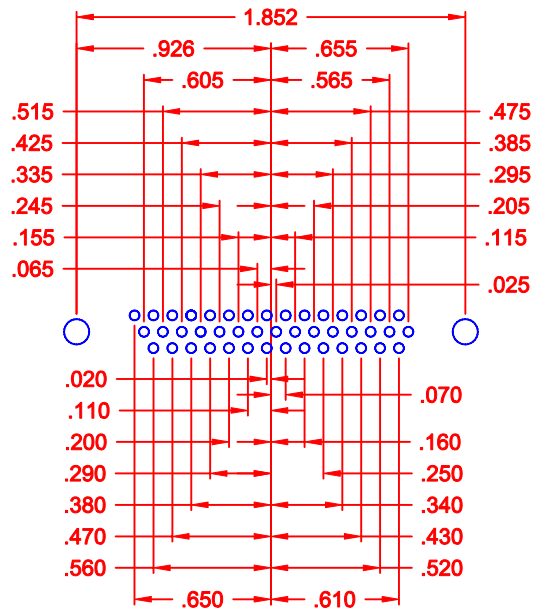

44 POSITION

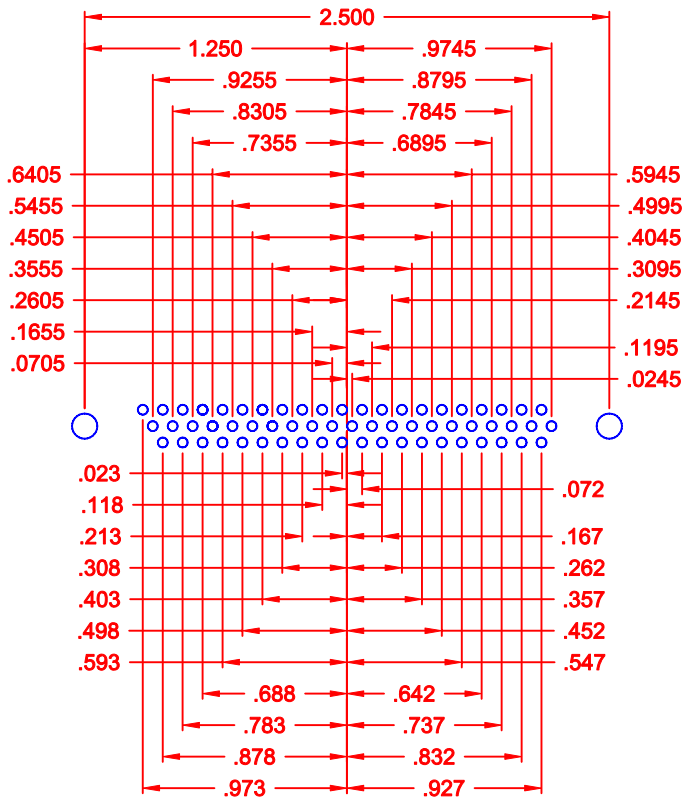

62 POSITION

* TYP. ON ALL SIZES

DO NOT SCALE FROM DRAWING

	THESE DRAWINGS AND SPECIFICATIONS ARE THE PROPERTY OF NorComp AND SHALL NOT BE REPRODUCED, COPIED OR USED AS THE BASIS FOR THE MANUFACTURE OF SALE OF APPARATUS WITHOUT WRITTEN PERMISSION.		DRAWN: C. SMITH	DATE: 03-16-07
			CHECKED:	DATE:
NorComp		SCALE: 1 : 1	SHEET 3 OF 3	REV 2
		DWG NO. 180-MYY-21YRYYY		