

THIS DRAWING IS UNPUBLISHED. RELEASED FOR PUBLICATION
 © COPYRIGHT BY TYCO ELECTRONICS CORPORATION. ALL RIGHTS RESERVED.

LOC		DIST		REVISIONS			
P	LTR	DESCRIPTION	DATE	DWN	APVD		
DF	DO	T	REV PER ECO 07-025060	10-29-07	CT	BW	

WHEN ORDERING CONTACT ON TAPE, ORDER BY THE TAPE NUMBER PLUS THE PACKAGING CODE AS FOLLOWS:

- 2. FOR USE WITH AMP TAPETRONIC, PNEUMATIC TOOL-
 - A. 1000 PARTS TO A BOX ADD PACKAGING CODE: 1MBOX
- 3. FOR USE WITH 4/8 INDENT STRIPPER CRIMP-
 - A. 1000 PARTS TO A REEL ADD PACKAGING CODE: 1MREEL
 - B. 5000 PARTS TO A REEL ADD PACKAGING CODE: 5MREEL

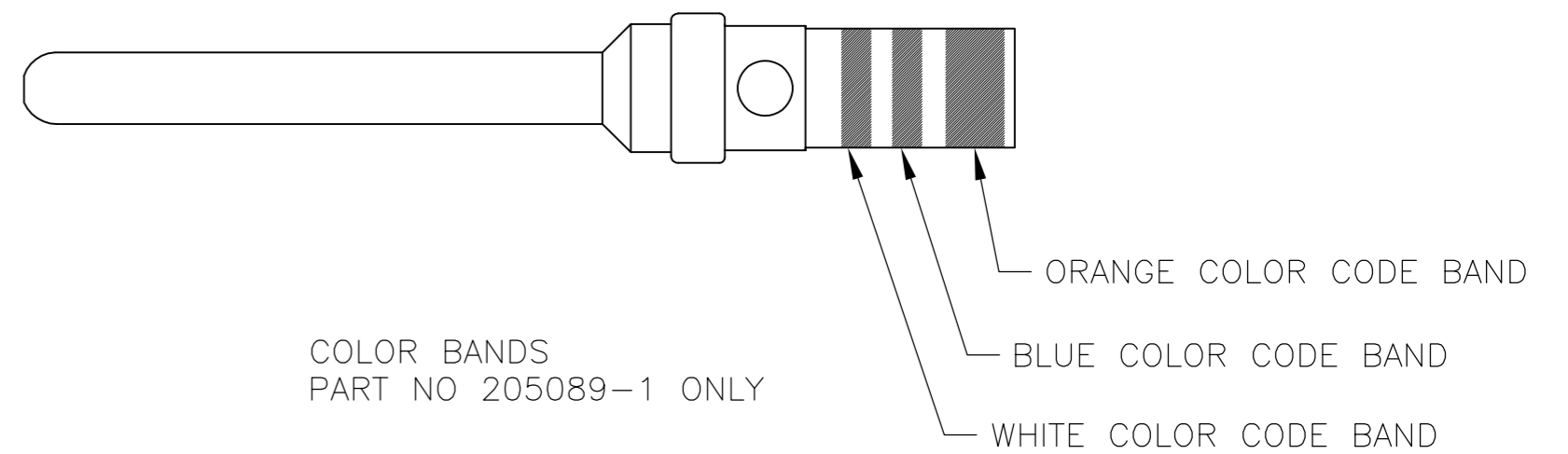
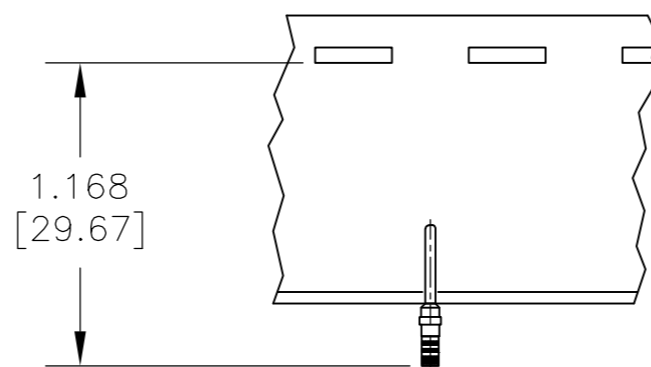
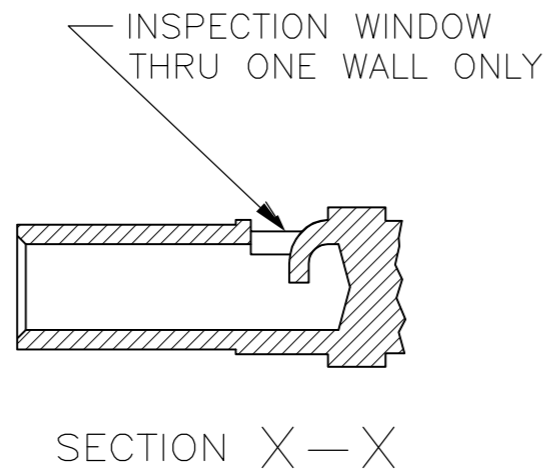
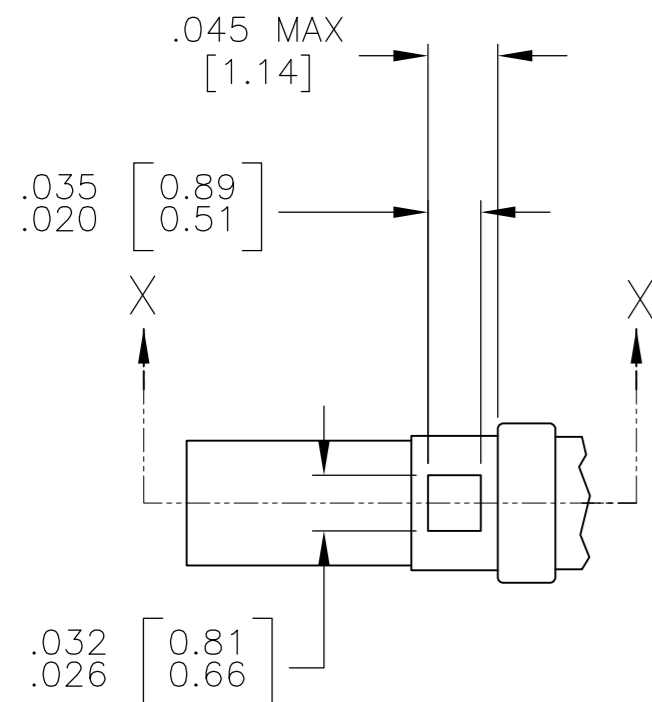
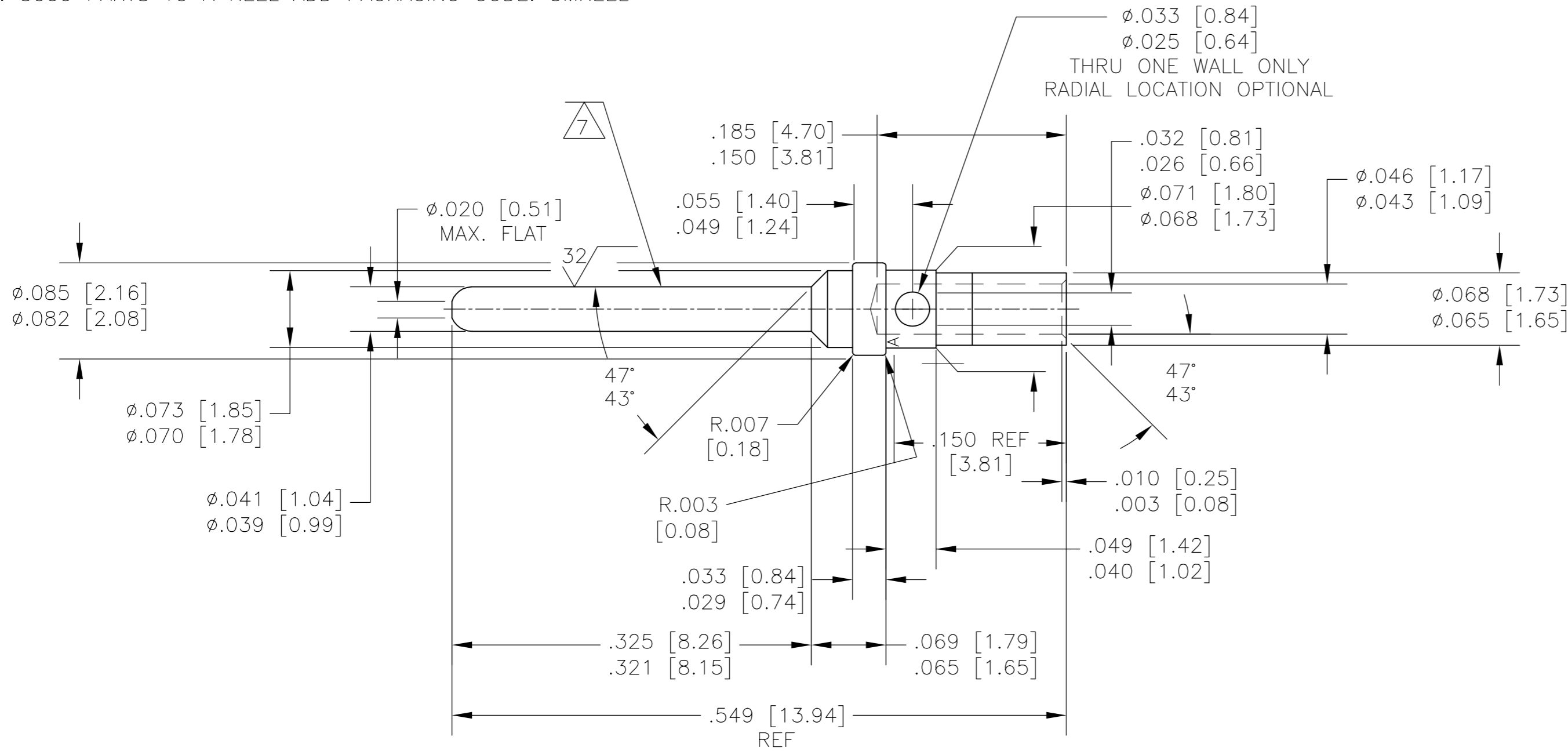

- 1 MATERIAL: COPPER ALLOY PER MIL-C-39029 & MIL-DTL-24308.
- 2. ALL DIMENSIONS APPLY AFTER PLATING.
- 3 THIS DRAWING COMPLIES WITH SPECIFICATION MIL-C-39029/64 & M24308/11-1.
- 4. ALL DIAMETERS CONCENTRIC WITH EACH OTHER WITHIN .004 T.I.R.
- 5. PIN MATES WITH SOCKET 205090 (MIL-C-39029/63).
- 6. ALL SURFACES HAVE $\sqrt{63}$ OR BETTER FINISH, UNLESS SHOWN.
- 7 POINT OF PLATING MEASUREMENT .188 [4.78] FROM TIP OF PIN.
- 8 PLATING: GOLD PER ASTM-B-488 (TYPEII) OVER NICKEL PER QQ-N-290.
- 9 PLATING: GOLD PER ASTM-B-488 (TYPEII) OVER COPPER PER MIL-C-14550, CLASS 4.
- 10 PLATING: GOLD PER ASTM-B-488 (TYPE II, CLASS 0) OVER NICKEL PER QQ-N-290.

WITHOUT COLOR CODE	8	1-205089-1
WITHOUT COLOR CODE	10	1-205089-0
WITHOUT COLOR CODE	9	205089-4
CONTACT ON TAPE	SAME AS -1	205089-2
AS SHOWN	8	205089-1
DESCRIPTION	PLATING	PART NO.

THIS DRAWING IS A CONTROLLED DOCUMENT.		DWN	25AUG2003	Tyco Electronics Corporation		
DIMENSIONS: INCHES		CHK	J. KAISER	Tyco Electronics Corporation		
TOLERANCES UNLESS OTHERWISE SPECIFIED:		APVD	D. MILLER	Harrisburg, PA 17105-3608		
0 PLC	± -	PRODUCT SPEC	D. MILLER	NAME		
1 PLC	± -	APPLICATION SPEC	D. MILLER	PIN SIZE 20 CONTACT, AMPLIMITE		
2 PLC	± -	WEIGHT	-	SIZE	CAGE CODE	DRAWING NO
3 PLC	± -	MATERIAL	-	A2	00779	C=205089
4 PLC	± -	FINISH	-	SCALE	SHEET	RESTRICTED TO
ANGLES	± -	CUSTOMER DRAWING	-	10:1	1 of 1	REV T