

THIS DRAWING IS UNPUBLISHED. RELEASED FOR PUBLICATION APR , 2003.

© COPYRIGHT 2003 BY TYCO ELECTRONICS CORPORATION. ALL RIGHTS RESERVED.

LOC	DIST	REVISIONS			
P	LTR	DESCRIPTION	DATE	DWN	APVD
E	B	F	ECR-08-030242	02DEC08	AM NC
		F1	REVISED PER ECO-09-024606	30OCT09	KK AEG

NOTES:

- MATERIAL**
 HOUSING : THERMOPLASTIC, UL94V-0, BLACK
 CONTACTS : BRASS.
 SHELL : STEEL
 SCREW : BRASS.
 BOARD LOCK : BRASS.
 SCREW OF TORQUE : 5 Kg-cm MAX.
- FINISH**
 CONTACT : 15µ" MIN.GOLD PLATING ON CONTACT AREA
 100µ" MIN. TIN PLATING ON SOLDER TAILS
 50µ" MIN. NICKEL UNDERPLATED OVERALL
 SHELL : 60µ" MIN. TIN PLATING
 SCREW : 50µ" MIN. NICKEL PLATING.
 BOARD LOCK : 50µ" MIN. NICKEL PLATING.
- CHARACTERISTICS**
 CURRENT RATING : 3A
 INSULATION RESISTANCE : 1000MOHMS MIN, 500VDC FOR 2MINS.
 TEMPERATURE RATING : -55DEGC ~ +105DEGC
 VOLTAGE RATING : 250VDC

⚠ OBSOLETE PARTS: OBSOLETE CIS STREAMLINING PER D.RENAUD/D.SINISI

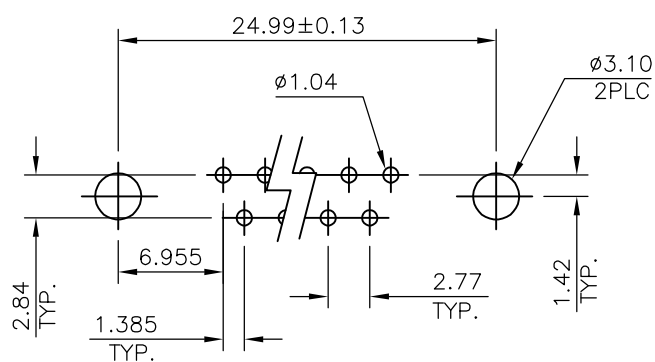
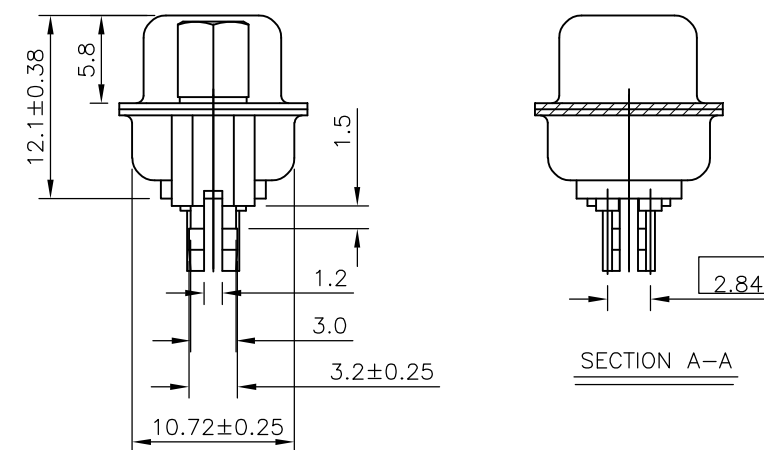
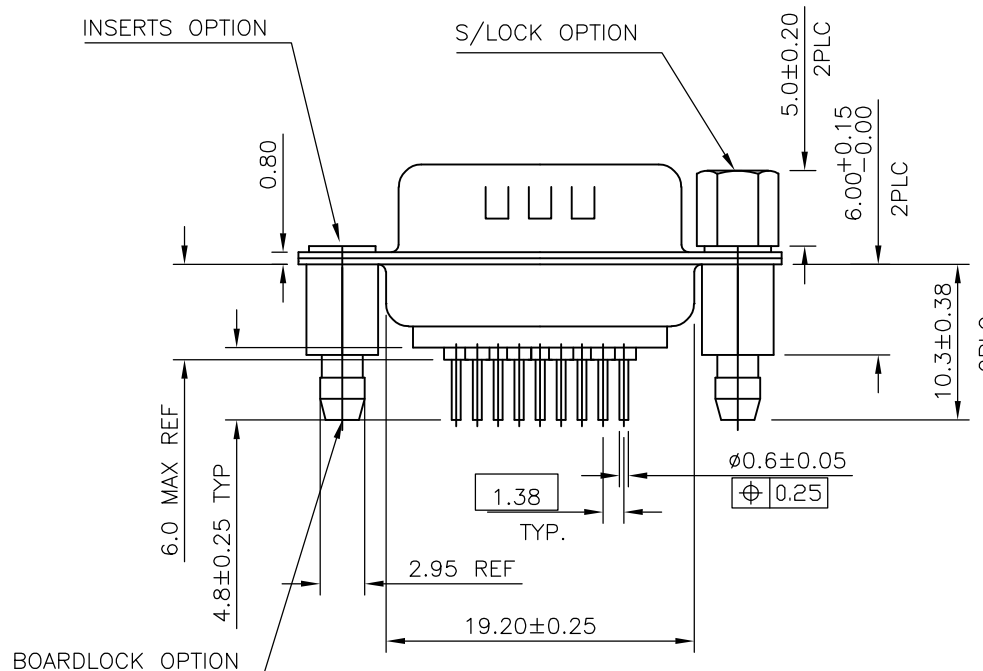
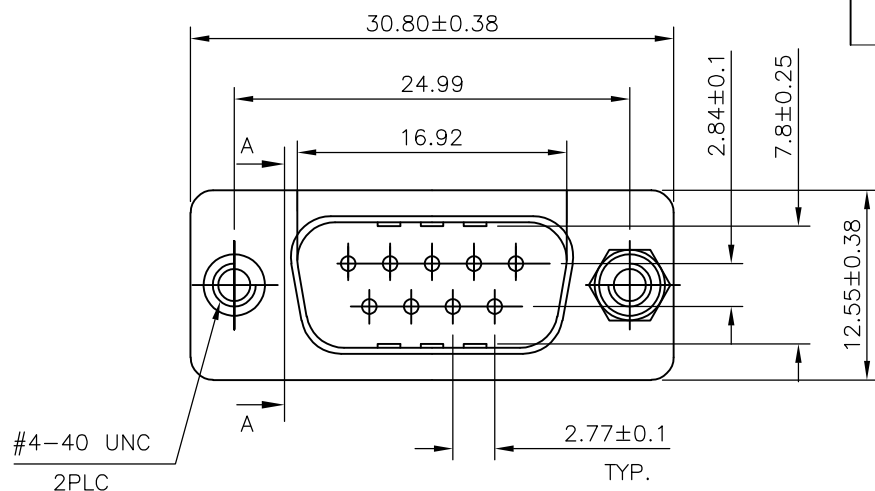

RECOMMENDED PCB LAYOUT(TOP VIEW)
(PCBTOLERANCE : ±0.05)

⚠ OBSOLETE

9W D PLG WITH B/L & M3 S/LOCK 15µ" GOLD	4-1634218-2
9W D PLG WITH B/L & 4-40 S/LOCK 15µ" GOLD	3-1634218-2
9W D PLG WITH B/L & M3 INSERTS 15µ" GOLD	2-1634218-2
9W D PLG WITH B/L & 4-40 INSERTS 15µ" GOLD	1-1634218-2
DESCRIPTION	TE PART No.

THIS DRAWING IS A CONTROLLED DOCUMENT.		DWN J.SANDWELL 10APR03		Tyco Electronics Corporation Stanmore, Middlesex, HA7 4RS	
DIMENSIONS: MM		CHK R.DYER 10APR03		NAME	
TOLERANCES UNLESS OTHERWISE SPECIFIED:		APVD F.WHEELER-KING 10APR03		D-SUB HD20, VERTICAL, 9P PLUG CONNECTOR	
0 PLC ± -	1 PLC ± 0.25	PRODUCT SPEC		SIZE	
2 PLC ± 0.15	3 PLC ± -	APPLICATION SPEC		CAGE CODE	DRAWING NO
4 PLC ± -	ANGLES ± -	WEIGHT		A3 00779	C-1634218
MATERIAL	FINISH	CUSTOMER DRAWING		RESTRICTED TO	
		SCALE 2:1		SHEET 1 OF 2	REV F1

LOC	DIST	REVISIONS		
E	B	P	LTR	DESCRIPTION
				DATE
				DWN
				APVD
				—
				—
				—

D

D

C

C

B

B

A

A

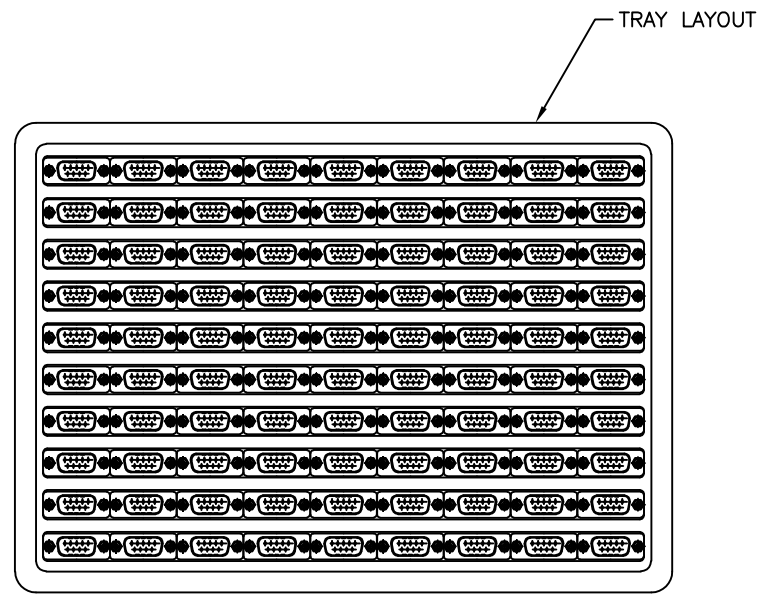
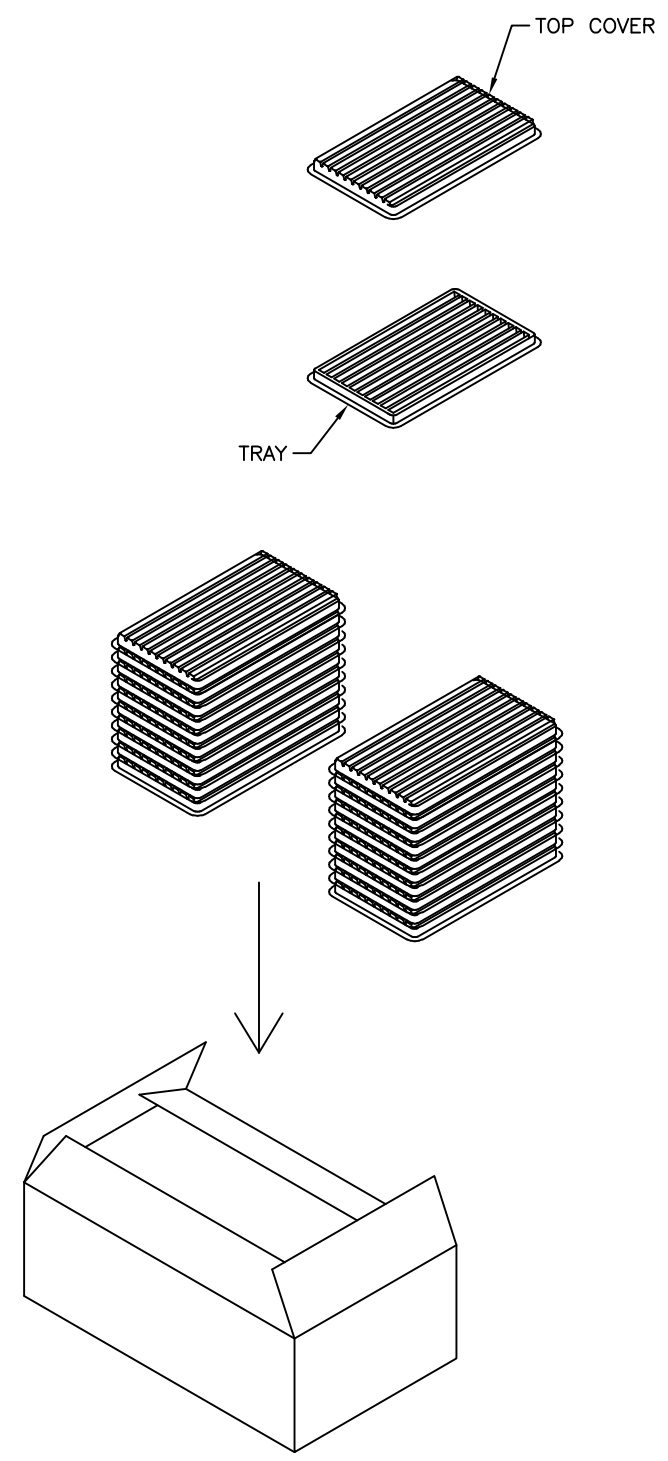

NOTES:

MATERIAL

1. TRAY: PVC
2. SHIPPING CARTON: CORRUGATED FIBERBOARD

DIMENSIONS

1. TRAY: L=310, W=230, H=21
2. SHIPPING CARTON: L=465, W=320, H=230

QUANTITY

- 90 PCS/TRAY
- 20 TRAY/SHIPPING CARTON

THIS DRAWING IS A CONTROLLED DOCUMENT.		DWN	J.SANDWELL	10APR03	Tyco Electronics Corporation Stanmore, Middlesex, HA7 4RS	
DIMENSIONS: MM		CHK	R.DYER	10APR03	NAME	
TOLERANCES UNLESS OTHERWISE SPECIFIED:		APVD	F.WHEELER-KING	10APR03	D-SUB HD20, VERTICAL, 9P PLUG CONNECTOR	
0 PLC ± -		PRODUCT SPEC	-			
1 PLC ± 0.25		APPLICATION SPEC	-			
2 PLC ± 0.15		WEIGHT	-			
3 PLC ± -		CUSTOMER DRAWING	-			
4 PLC ± -		SCALE	NTS			
ANGLES ± -		FINISH	-			
MATERIAL		SIZE	A3	CAGE CODE	00779	DRAWING NO
-		RESTRICTED TO	-			
		SCALE	NTS		SHEET	2 OF 2
		REV	F1			
		DRAWING NO	C-1634218			