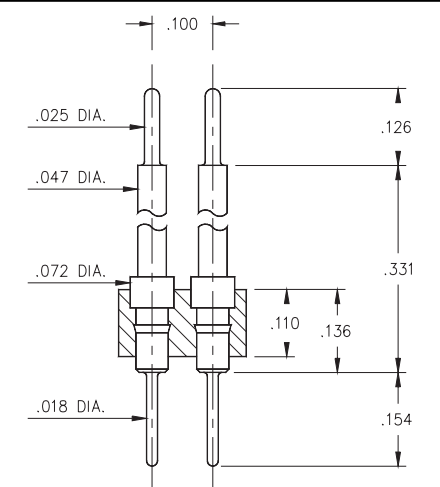
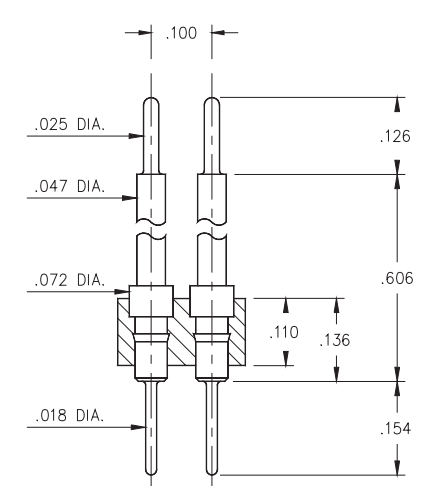

**Fig. 1**



**Fig. 2**



**Fig. 3**

- Series 451 Interconnect header strips come in three lengths with .018" dia. pluggable solder tails at one end and .025" dia. pins at the other, see series:  
451...003 uses pin #5503  
451...004 uses pin #5504  
451...005 uses pin #5505
- .018" pluggable solder tails are available at both ends, please see series:  
451...009 uses pin #5509  
451...010 uses pin #5510  
451...011 uses pin #5511  
See pages 179 & 181 for details.
- Insulators are high temp. thermoplastic.



### Ordering Information

|               |   |
|---------------|---|
| <b>Fig. 1</b> | <b>Series 451...003</b> <b>.018 / .025 Solder Tails</b>       |
|               | 451-10-2_ _ -00-003000<br>Specify # of pins      ↳      02-64 |
| <b>Fig. 2</b> | <b>Series 451...009</b> <b>.018 / .018 Solder Tails</b>       |
|               | 451-10-2_ _ -00-009000<br>Specify # of pins      ↳      02-64 |
| <b>Fig. 3</b> | <b>Series 451...004</b> <b>.018 / .025 Solder Tails</b>       |
|               | 451-10-2_ _ -00-004000<br>Specify # of pins      ↳      02-64 |
| <b>Fig. 3</b> | <b>Series 451...010</b> <b>.018 / .018 Solder Tails</b>       |
|               | 451-10-2_ _ -00-010000<br>Specify # of pins      ↳      02-64 |
| <b>Fig. 3</b> | <b>Series 451...005</b> <b>.018 / .025 Solder Tails</b>       |
|               | 451-10-2_ _ -00-005000<br>Specify # of pins      ↳      02-64 |
| <b>Fig. 3</b> | <b>Series 451...011</b> <b>.018 / .018 Solder Tails</b>       |
|               | 451-10-2_ _ -00-011000<br>Specify # of pins      ↳      02-64 |

*For Electrical, Mechanical & Environmental Data, See pg. 4*

*For RoHS compliance select ◇ plating code.*

|                |            |  |  |
|----------------|------------|--|--|
| PLATING CODE = | <b>10◇</b> |  |  |
| Pin Plating    | 10μ Au     |  |  |