

- 1 HOUSING AND TERMINATION COVERS: THERMOPLASTIC, UL94V-0 RATED, COLOR BLACK.
SHELL: STEEL.
PIN CONTACTS: PHOSPHOR BRONZE.
- 2 2.54μm [.000100] MIN TIN-NICKEL OVER 3.81μm [.000150] MIN NICKEL OVER 2.54μm [.000100] MIN COPPER.
- 3 5.08μm [.000200] MIN TIN OVER 1.27μm [.000050] MIN COPPER. LUBRICATED AFTER PLATING.
- 4 EITHER 0.76μm [.000030] MIN GOLD PLATE OR GOLD FLASH OVER PALLADIUM NICKEL PLATE, 0.76μm [.000030] MIN TOTAL IN LOCALIZED PLATE AREA, 3.00μm [.000118] MIN TIN IN TERMINATION AREA, ALL OVER 1.27μm [.000050] MIN NICKEL.
5. RECOMMENDED WIRE: 28 AWG OR 30 AWG, SOLID OR 7 STRAND, WITH A 0.74 - 0.91 [.029 - .036] INSULATION DIAMETER.
WIRE MUST BE APPROVED BY TYCO ELECTRONICS.

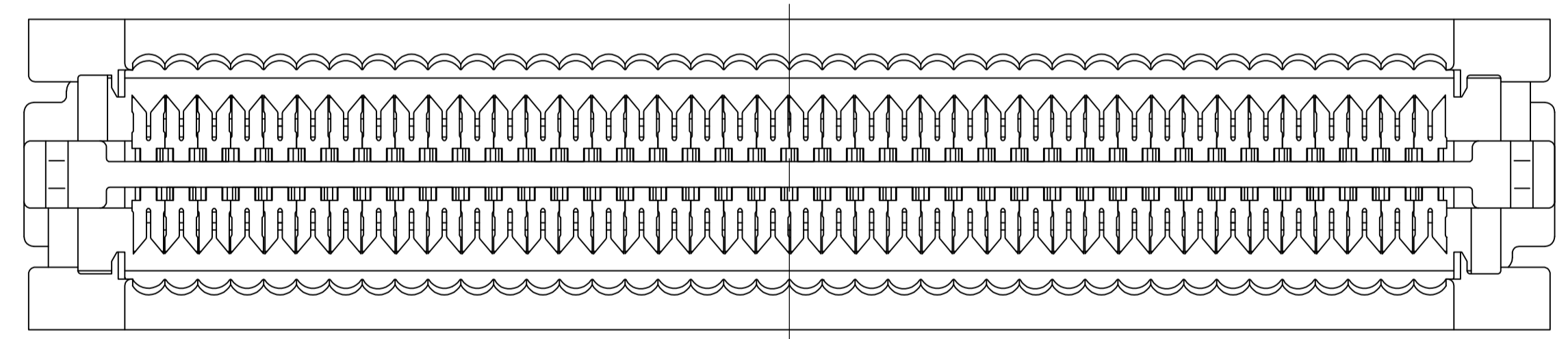
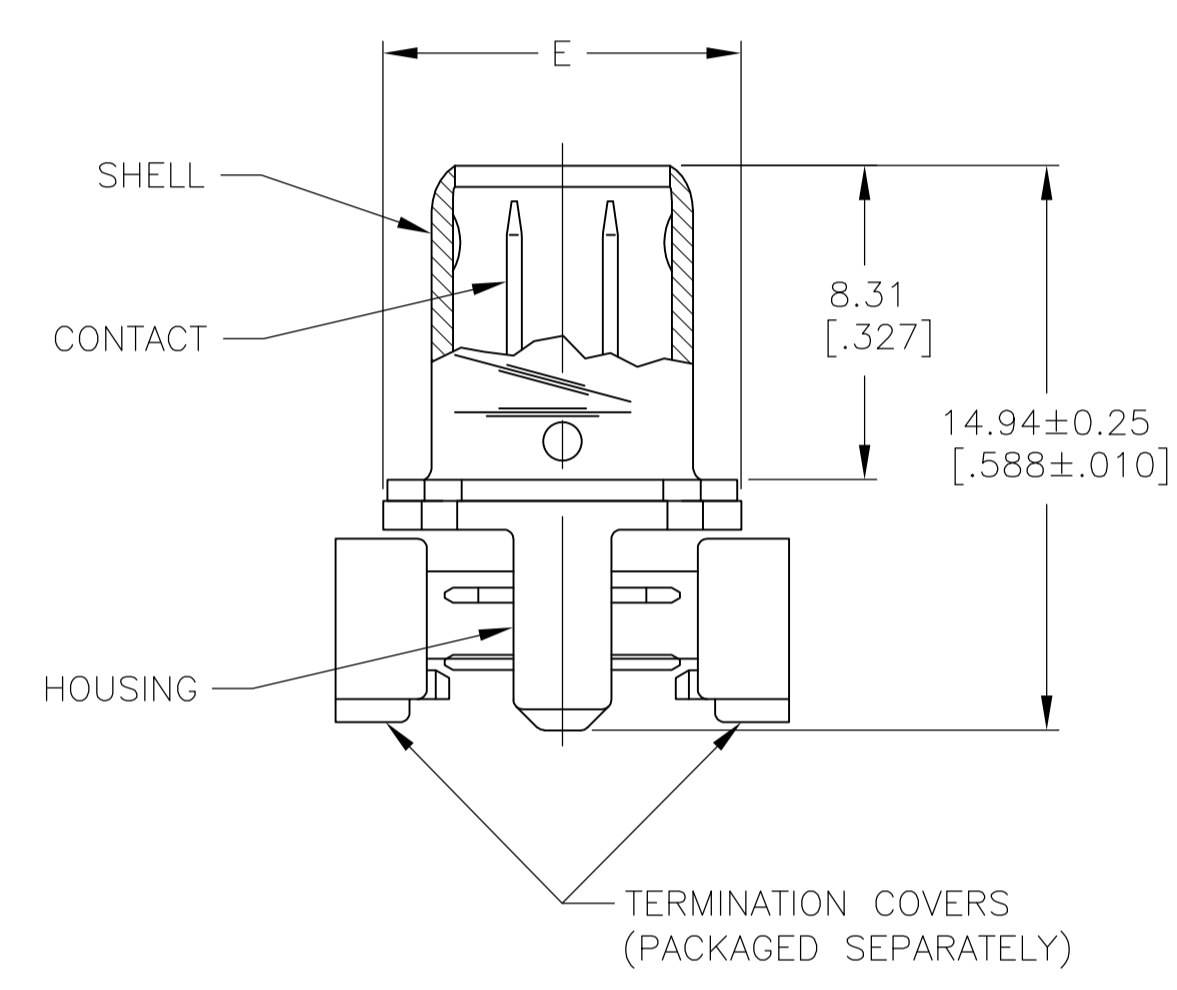
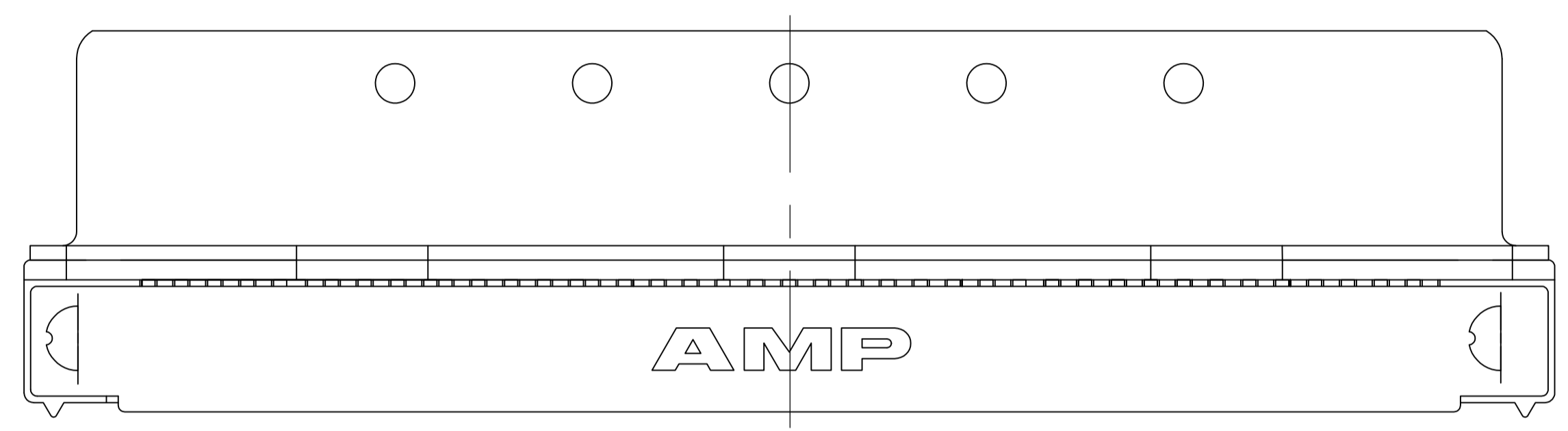

| | | | | | | | | | |
|-------------------------|----------------|------------------|------------------|------------------|----------------|--------------|-----------|-------------|-------------|
| SUPERCEDED BY 5749621-9 | 9.47 [.373] | 71.86 [2.829] | 66.60 [2.622] | 62.23 [2.450] | 49 | 4 | 2 | 100 | 1-5749621-8 |
| SUPERCEDED BY 5749621-5 | 7.44 [.293] | 40.11 [1.579] | 34.85 [1.372] | 30.48 [1.200] | 24 | 4 | 2 | 50 | 1-5749621-7 |
| SUPERCEDED BY 5749621-7 | 7.44 [.293] | 51.54 [2.029] | 46.28 [1.822] | 41.91 [1.650] | 33 | 4 | 3 | 68 | 1-5749621-6 |
| | 9.47 [.373] | 84.54 [3.329] | 79.31 [3.122] | 74.93 [2.950] | 59 | 4 | 2 | 120 | 1-5749621-0 |
| | 9.47 [.373] | 71.86 [2.829] | 66.60 [2.622] | 62.23 [2.450] | 49 | 4 | 2 | 100 | 5749621-9 |
| | 9.47 [.373] | 59.16 [2.329] | 53.90 [2.122] | 49.53 [1.950] | 39 | 4 | 2 | 80 | 5749621-8 |
| | 7.44 [.293] | 51.54 [2.029] | 46.28 [1.822] | 41.91 [1.650] | 33 | 4 | 2 | 68 | 5749621-7 |
| | 7.44 [.293] | 40.11 [1.579] | 34.85 [1.372] | 30.48 [1.200] | 24 | 4 | 2 | 50 | 5749621-5 |
| | 7.44 [.293] | 33.76 [1.329] | 28.50 [1.122] | 24.13 [.950] | 19 | 4 | 2 | 40 | 5749621-4 |
| | 7.44 [.293] | 26.14 [1.029] | 20.88 [.822] | 16.51 [.650] | 13 | 4 | 2 | 28 | 5749621-3 |
| | 7.44 [.293] | 24.87 [.979] | 19.61 [.772] | 15.24 [.600] | 12 | 4 | 2 | 26 | 5749621-2 |
| | 7.44 [.293] | 21.06 [.829] | 15.80 [.622] | 11.43 [.450] | 9 | 4 | 2 | 20 | 5749621-1 |
| E | D | C | B | A | CONTACT FINISH | SHELL FINISH | NO OF POS | PART NUMBER | |

**COPYRIGHT 2005
 TYCO ELECTRONICS CORP
 ALL RIGHTS RESERVED**

| | | | | |
|--|--|-------------------------------|---|-----------------|
| THIS DRAWING IS A CONTROLLED DOCUMENT. | | DIN J.GERACE 17FEB05 | Tyco Electronics Corporation Harrisburg, Pa 17105-3608 | |
| DIMENSIONS: INCHES | | CHK S.SHUEY 17FEB05 | Tyco Electronics | |
| TOLERANCES UNLESS OTHERWISE SPECIFIED: | | APVD M.WALMSLEY 17FEB05 | NAME KIT, PLUG ASSEMBLY, 1.27[.050] SERIES, AMPLIMITE | |
| 0 PLC ± - 1 PLC ± - 2 PLC ± 0.13[.005] 3 PLC ± - 4 PLC ± - ANGLES ± - | | PRODUCT SPEC 108-1228 | RESTRICTED TO | |
| MATERIAL 1 | | APPLICATION SPEC 114-40029 | SIZE A1 | SCALE 5:1 |
| SEE TABLE | | WEIGHT - | DRAWING NO 5749621 | SHEET 1 OF 1 |
| | | CUSTOMER DRAWING | REV C | |