

THIS DRAWING IS UNPUBLISHED. RELEASED FOR PUBLICATION AUG. 2006.
 © COPYRIGHT 2009 BY TYCO ELECTRONICS CORPORATION. ALL RIGHTS RESERVED.

LOC		DIST		REVISIONS					
DW		-		P	LTR	DESCRIPTION	DATE	DWN	APVD
				B		REVISED (ECR-10-009968)	10MAY10	JL	WK

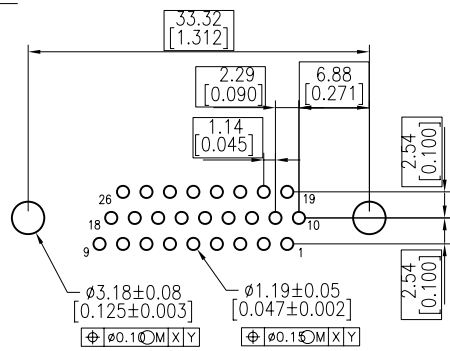
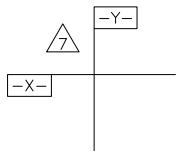
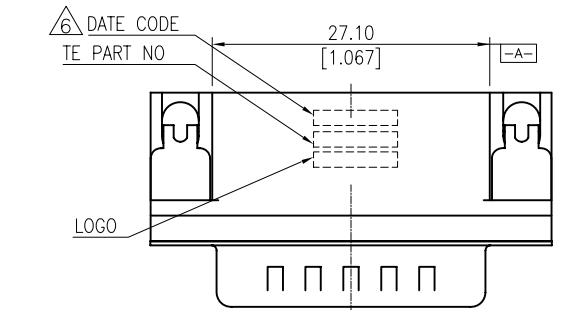

RECOMMENDED PCB LAYOUT

- HOUSING: PBT, BLACK, UL94V-0.
- CONTACT: BRASS, GOLD PLATE IN THE MATING AREA (SEE TABLE), 120u" MINIMUM TIN PLATE ON THE SOLDER-TAIL BOTH OVER 50u" MINIMUM NICKEL UNDERPLATE.
- SHELL: STEEL, NICKEL PLATE.
- BOARDLOCK: BRASS, 100u" MINIMUM TIN PLATE
- THREADED INSERT: BRASS, NICKEL PLATE
- △ FOUR DIGIT DATE CODE IN THIS FORMAT.

01 45
 YEAR ——— MANUFACTURING WEEK

△ DATUMS -X- & -Y- TO BE ESTABLISHED BY CUSTOMER.

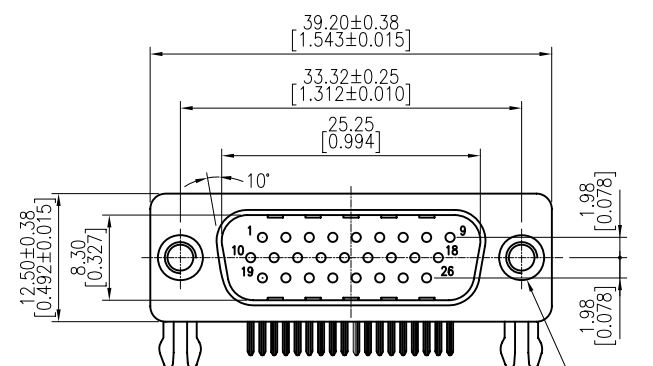

SEE TABLE FOR MOUNTING CONFIGURATION

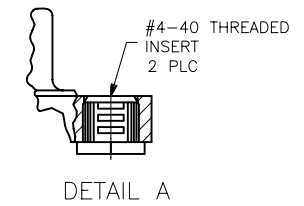
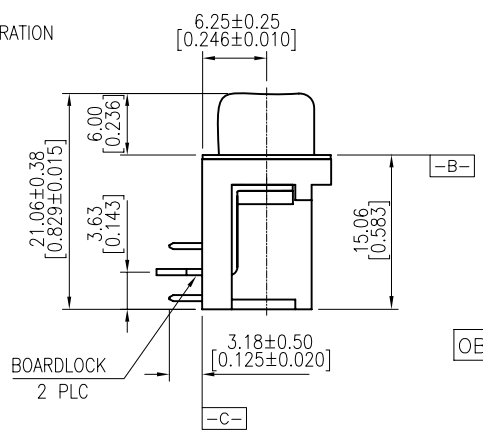
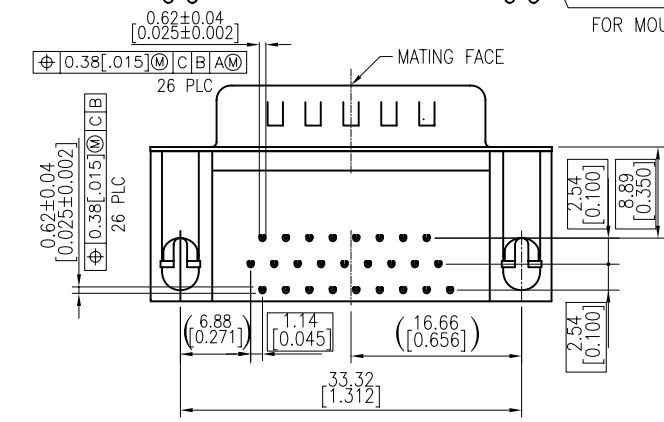

	TRAY	DETAIL A	GOLD FLASH	5749769-3
OBsolete	TRAY	DETAIL A	15µ" MIN	5749769-2
	TRAY	DETAIL A	30µ" MIN	5749769-1
PACKAGING	MOUNTING FLANGE CONFIG	CONTACT MATING AREA FINISH	PART NUMBER	

THIS DRAWING IS A CONTROLLED DOCUMENT.		CHK R. RICHARDSON 22APR2005	Tyco Electronics Corporation Tyco Electronics Taipei, Taiwan	
DIMENSIONS: MM		CHK S. BOLASH 22APR2005	NAME	
TOLERANCES UNLESS OTHERWISE SPECIFIED:		APVD M. WALMSLEY 22APR2005	PRODUCT SPEC	
0 PLC ± -		APPLICATION SPEC		
1 PLC ± 0.30		WEIGHT		
2 PLC ± 0.20		CUSTOMER DRAWING		
3 PLC ± 0.10		SCALE		
4 PLC ± -		SHEET		
ANGLES ± 2'		REV		
MATERIAL SEE NOTE		FINISH SEE NOTE		RESTRICTED TO
		SIZE CAGE CODE DRAWING NO		
		A3 00779 C-5749769		
		1 OF 2		

THIS DRAWING IS UNPUBLISHED. RELEASED FOR PUBLICATION AUG .2006.
 © COPYRIGHT 2009 BY TYCO ELECTRONICS CORPORATION. ALL RIGHTS RESERVED.

LOC DW	DIST	REVISIONS			
P	LTR	DESCRIPTION	DATE	DWN	APVD
		SEE SHEET 1.			

D

C

B

A

D

C

B

A

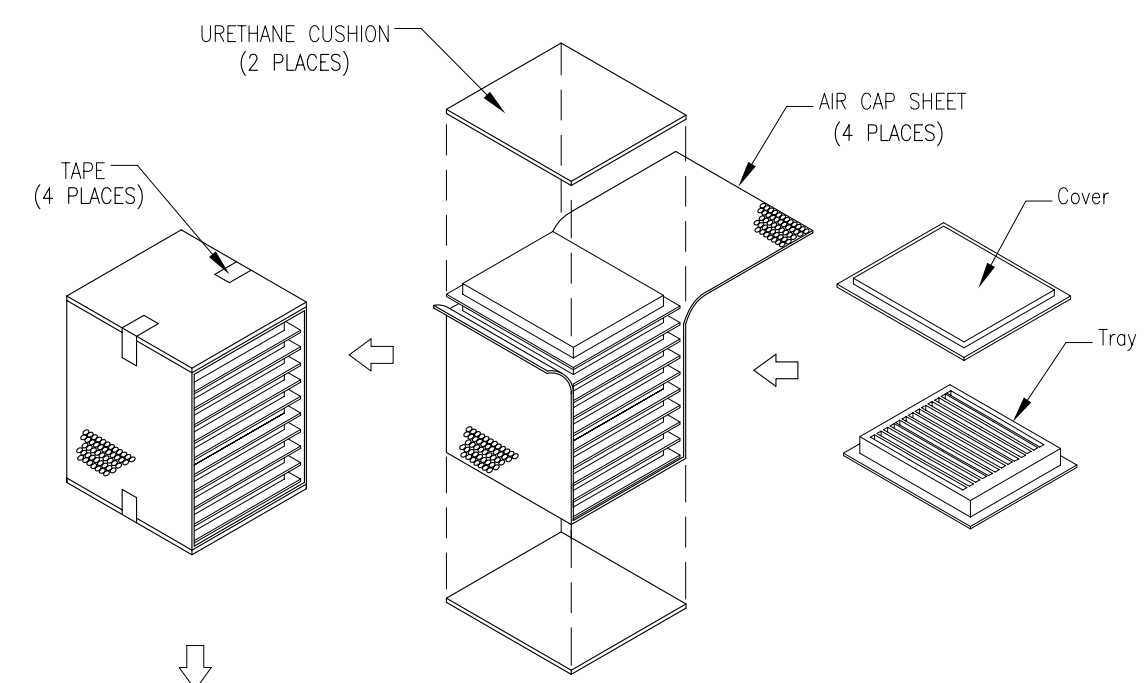

NOTES:

- MATERIAL:
 - 1.1 TRAY: PVC
 - 1.2 SHIPPING CARTON: CORRUGATED FIBERBOARD
- DIMENSION:
 - 2.1 TRAY: L=32.0X23.0X1.89 CM
 - 2.2 SHIPPING CARTON: L=36.1X24.5X27.2 CM
- QUANTITY:
 - 3.1 PRIMARY PACKING: 80 PCS/TRAY
 - 3.2 SECONARY PACKING: 10 TRAY/CARTON(800PCS)
- WEIGHT:
 - 4.1 NET WEIGHT: 9.54 Kg
 - 4.2 GROSS WEIGHT: 11.54 Kg

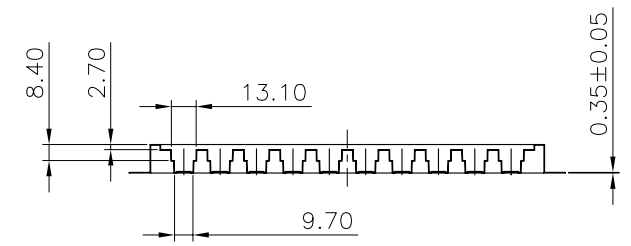
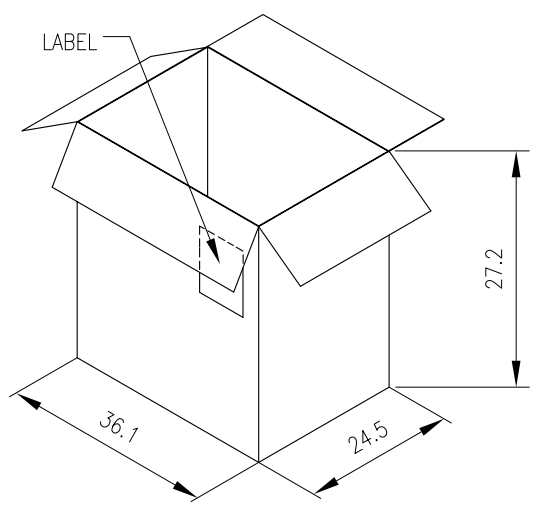
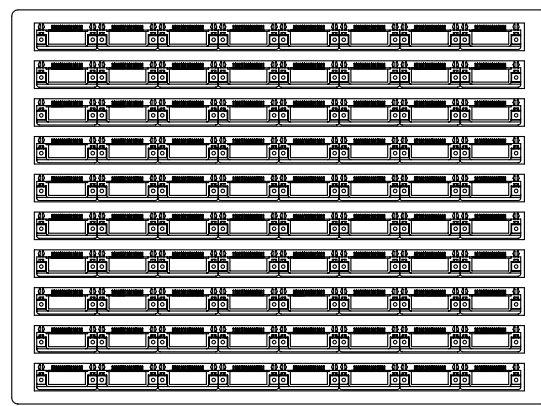

THIS DRAWING IS A CONTROLLED DOCUMENT.		DWN	Tyco Electronics Corporation Taipei, Taiwan	
DIMENSIONS: MM		CHK	NAME	
TOLERANCES UNLESS OTHERWISE SPECIFIED:		APVD	PLUG ASSEMBLY, RIGHT ANGLE, 26 POSITION, HD-22, AMPLIMITE	
0 PLC ± -		PRODUCT SPEC	SIZE CAGE CODE DRAWING NO RESTRICTED TO	
1 PLC ± -		APPLICATION SPEC	A3 00779 C-5749769	
2 PLC ± -		WEIGHT	SCALE SHEET 2 of 2 REV B	
3 PLC ± -		CUSTOMER DRAWING		
4 PLC ± -				
ANGLES ± -				
FINISH				