

THIS DRAWING IS UNPUBLISHED. RELEASED FOR PUBLICATION  
 © COPYRIGHT BY TYCO ELECTRONICS CORPORATION. ALL RIGHTS RESERVED.

LOC	DIST	REVISIONS					
GP	00	P	LTR	DESCRIPTION	DATE	DWN	APVD
		F		REVISED PER ECO-10-019804	28OCT10	HMR	JL

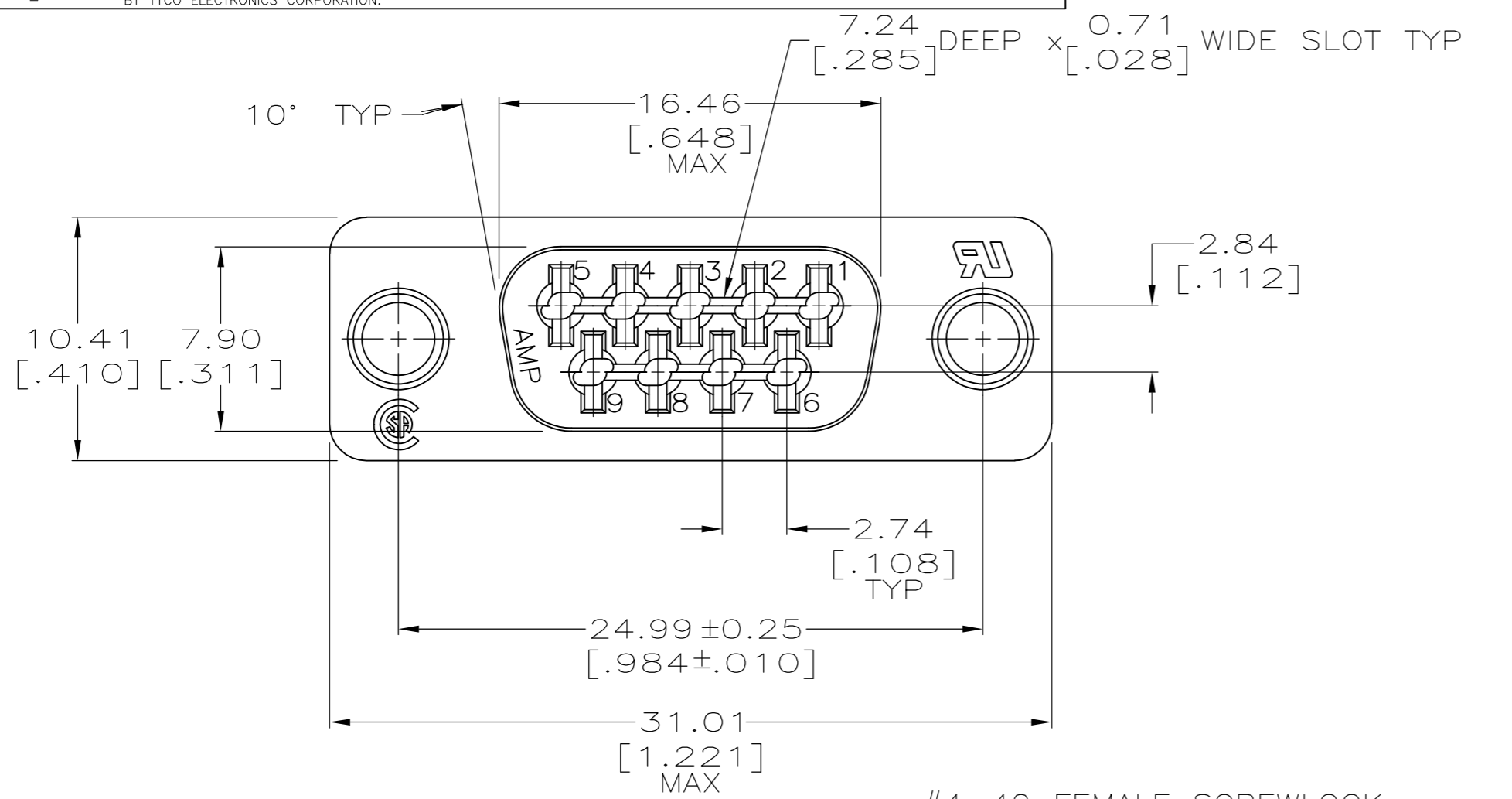

- 1 P.C. BOARD RECOMMENDATIONS:  
 A. HOLES SHOULD BE DRILLED WITH A 1.15 mm DRILL.  
 B. MINIMUM P.C.B. TIN/LEAD PLATING TO BE 7.62µm [.000300] THK OVER 0.05±0.03 [.002±.001] THK COPPER.  
 C. RECOMMENDED HOLE SIZE AFTER TIN/LEAD PLATING IS 0.94 [.037] TO 1.09 [.043] FOR P.C.B. 2.36 [.093] TO 3.18 [.125] THK.  
 D. IF HOLE IS REFLOWED AFTER PLATING, DIA. TO BE 0.91 [.036] TO 1.09 [.043].
- 2 GOLD FLASH ON MATING SURFACE, BRIGHT TIN OR BRIGHT TIN LEAD ON COMPLIANT PIN, ALL OVER NICKEL.
- 3 CONTACTS:  
 0.76 MICRO METERS [.000030] MINIMUM GOLD IN MATING AREA.  
 2.54 MICRO METERS [.000100] MINIMUM TIN OR TIN-LEAD ON COMPLIANT PIN. ALL OVER 1.27 MICRO METERS [.000050] MINIMUM NICKEL.  
 OR  
 GOLD FLASH OVER PALLADIUM NICKEL.  
 0.76 MICRO METERS [.000030] MINIMUM TOTAL IN MATING AREA.  
 2.54 MICRO METERS [.000100] MINIMUM TIN OR TIN-LEAD ON COMPLIANT PIN. ALL OVER 1.27 MICRO METERS [.000050] MINIMUM NICKEL.
- 4. SCREWLOCKS WILL WITHSTAND 4 INCH-LBS TORQUE AND 20 LBS PULL OUT FORCE FROM MATING FACE SIDE.
- 5 HOUSING: FLAME RETARDANT 94V-0 RATED THERMOPLASTIC, COLOR: BLACK
- 6 NICKEL PLATED

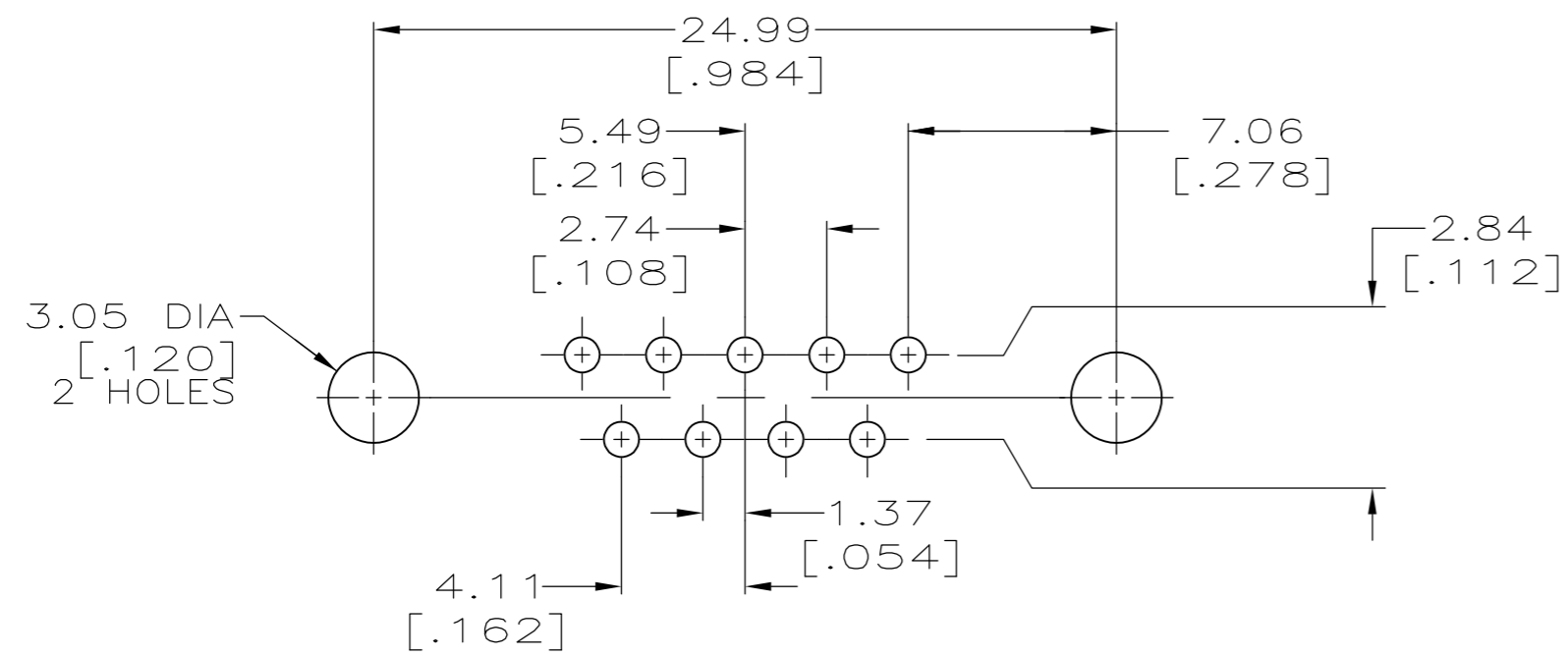
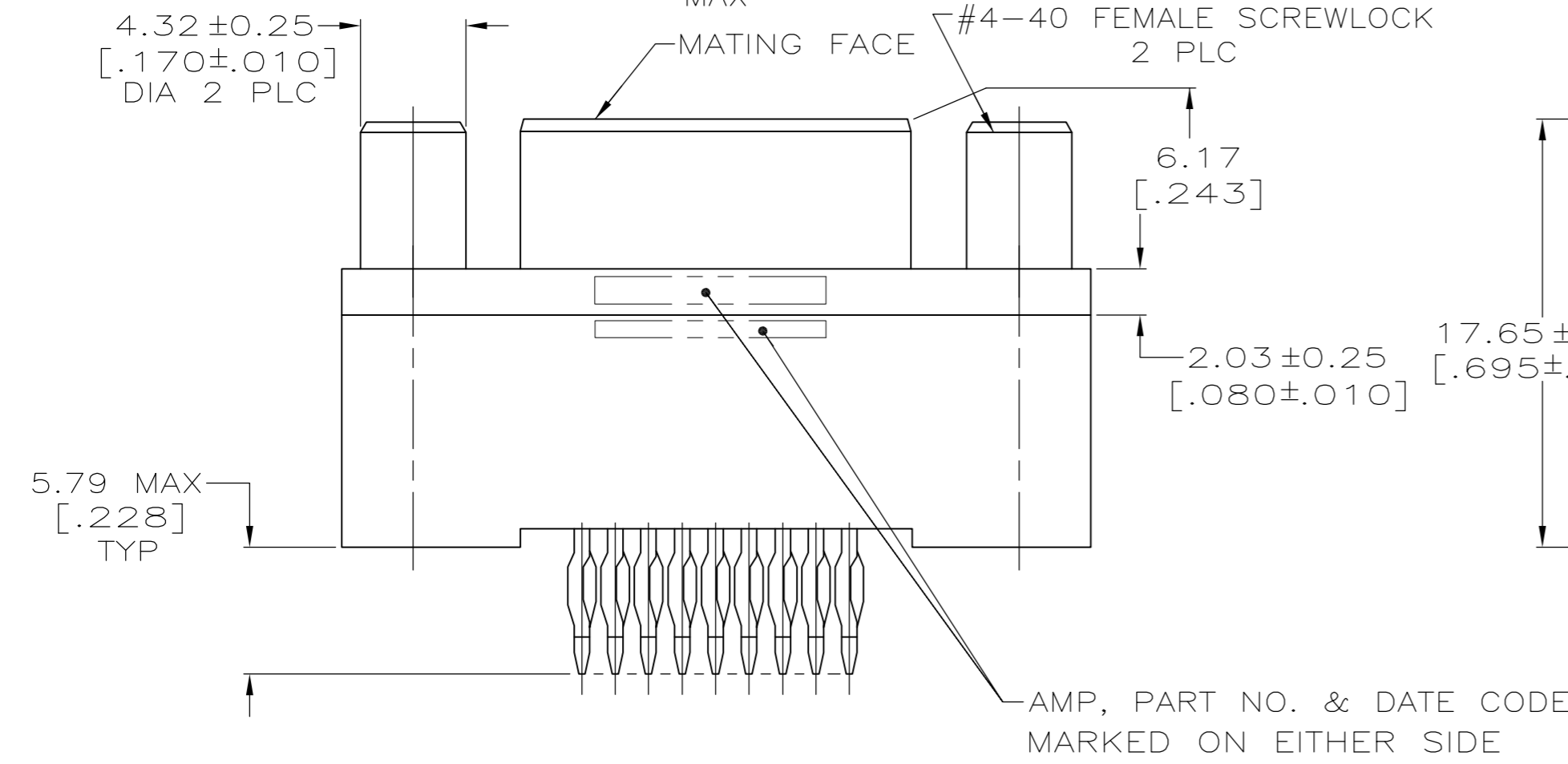

RECOMMENDED PC BOARD MOUNTING DIMENSIONS 1  
 CONNECTOR SIDE OF BOARD

SUPERSEDED BY 745455-2	6	3	745455-2
	6	2	745455-1
SCREWLOCKS FINISH	CONTACT FINISH	PART NUMBER	

THIS DRAWING IS A CONTROLLED DOCUMENT.		DWN K.FOLTZ 05/05/94	Tyco Electronics Corporation Tyco Electronics Corporation Harrisburg, PA 17105-3608	
DIMENSIONS: mm [INCHES]		CHK R.STONE 5-17-94	RCPT ASSY, SIZE 1, 9 POSN, W/ACTION PIN CONTACTS & FEMALE SCREWLOCKS, AMPLIMITE HD-20	
TOLERANCES UNLESS OTHERWISE SPECIFIED:		APVD -	NAME	RESTRICTED TO
0 PLC ± -		PRODUCT SPEC -	SIZE A2	CAGE CODE 00779
1 PLC ± -		APPLICATION SPEC -	DRAWING NO C=745455	REV F
2 PLC ± 0.13 [.005]		WEIGHT -	SCALE 4:1	SHEET 1 OF 1
3 PLC ± -		CUSTOMER DRAWING		
4 PLC ± -				
ANGLES ± -				
FINISH SEE TABLE				