

NOTES:

1. PRODUCT SPEC PS-87609-002 APPLIES.
2. PRODUCT IS PACKAGED IN TRAYS.
3. MATERIALS:
 - HOUSING- HIGH-TEMP THERMOPLASTIC, UL 94V-0
 - TERMINAL- PHOSPHOR BRONZE
 - LATCHES - HIGH-TEMP THERMOPLASTIC, UL 94V-0
 - FORKLOCKS - COPPER ALLOY OR STEEL ALLOY
 - BASE-PLATE - HIGH-TEMP THERMOPLASTIC, UL 94V-0
 - COVER - HIGH-TEMP THERMOPLASTIC, UL 94V-0
4. PLATING:
 - CONTACT AREA:
 - SEE TABLE ON SHEET 3 OF 3
 - FOR GOLD PLATING OPTION AT CONTACT AREA
 - SOLDER TAIL: 75uIN/(1.91uM) MIN. TIN/LEAD OR TIN
 - UNDERPLATE: 50uIN/(1.27uM) MIN. NICKEL

ADD FLAMMABILITY RATING EC NO: S2005-0928 2005/06/16 DRWN:SHLENI 2005/06/21 CHKD:SRAMESH 2005/06/21 APPR:GJLEE 2005/06/24	REV	DESCRIPTION
	D1	

QUALITY SYMBOLS
▽=0
▽C=0

GENERAL TOLERANCES (UNLESS SPECIFIED)
4 PLACES ± --- ± ---
3 PLACES ± --- ± ---
2 PLACES ± 0.25 ± ---
1 PLACE ± --- ± ---
ANGULAR ± 5 °
DRAFT WHERE APPLICABLE MUST REMAIN WITHIN DIMENSIONS

DIMENSION STYLE	SCALE	DESIGN UNITS	THIRD ANGLE PROJECTION
MM ONLY	NTS	METRIC	
DRAWN BY	DATE	TITLE	
SQUEK	2000/01/21	SALES DRAWING	
CHECKED BY	DATE	DIMM, 1.27MM PITCH	
KCLING	2000/03/01	168 CKTS, R/A	
APPROVED BY	DATE		
SKTOH	2000/03/03		
MATERIAL NO.	DOCUMENT NO.		
SEE TABLE	SD-87609-001		
SIZE A3			

MATERIAL NO.	DOCUMENT NO.	SHEET NO.
SEE TABLE	SD-87609-001	1 OF 3
THIS DRAWING CONTAINS INFORMATION THAT IS PROPRIETARY TO MOLEX INCORPORATED AND SHOULD NOT BE USED WITHOUT WRITTEN PERMISSION		

10 9 8 7 6 5 4 3 2 1

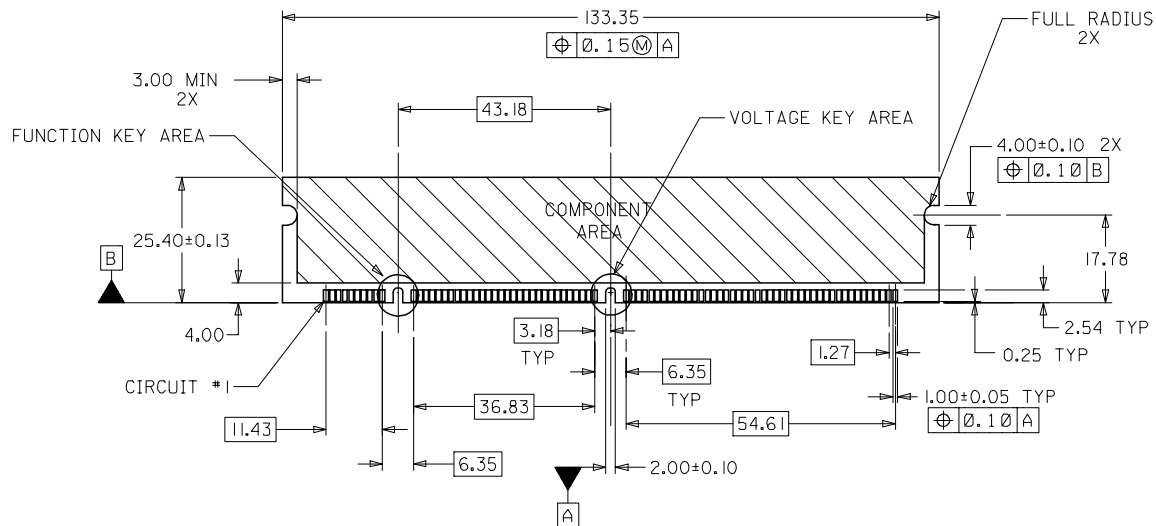

RECOMMENDED MODULE LAYOUT
(PER JEDEC STANDARD MO-161, I68 CKT. 3.3V)

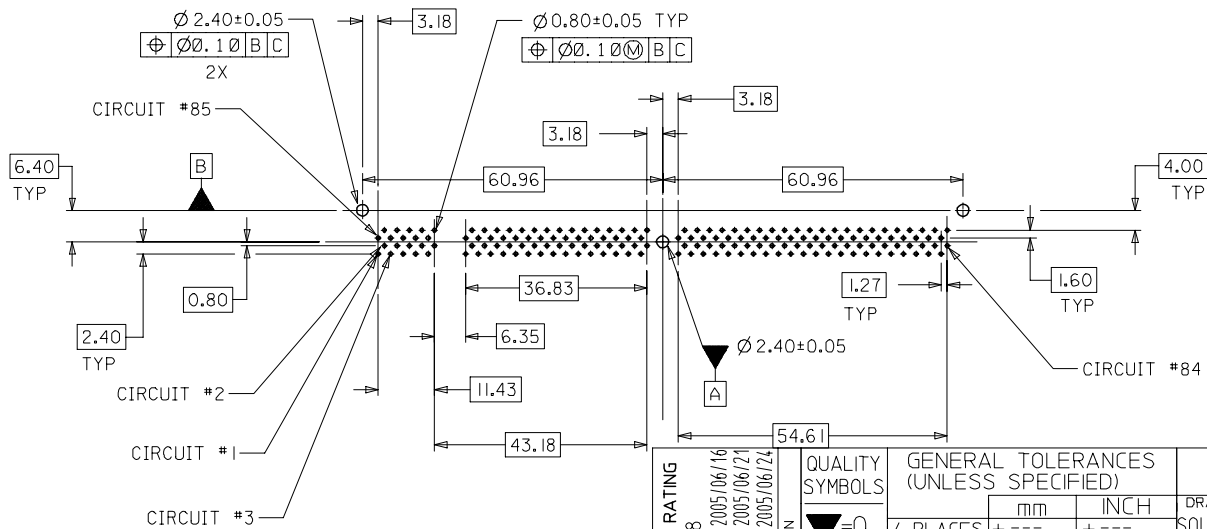

RECOMMENDED P.C. BOARD HOLE PATTERN
(CONNECTOR SIDE)

FUNCTION KEY AREA OPTIONS
(REFER ALSO TO TABLE ON SHT. 3)

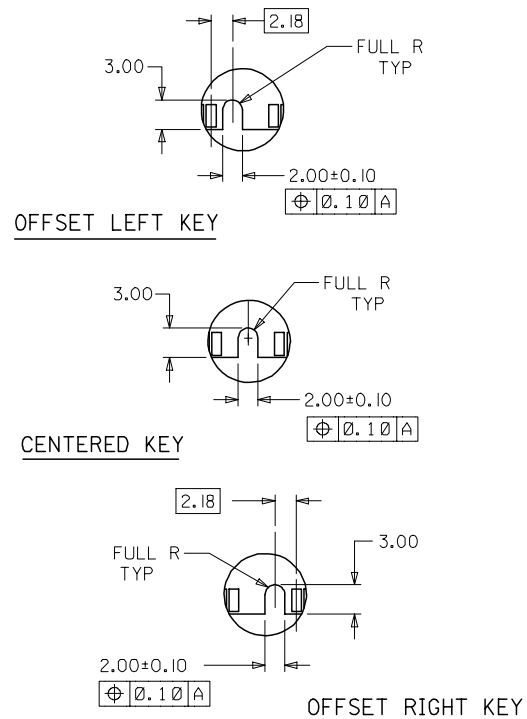

- NOTES:
1. STRAIGHTNESS OF MODULE APPLIES TO THE AREA FROM THE BOTTOM OF THE CARD UP 4.00(.157)
 2. RECOMMENDED PLATING ON MODULE PADS:
0.76 MICROMETER(30 MICROINCH) MINIMUM HARD GOLD OVER 2.0 MICROMETER(79 MICROINCH) MINIMUM NICKEL.

ADD FLAMMABILITY RATING EC NO: S2005-0928 2005/06/16 DRWN:SHLENI 2005/06/21 CHKD:SRAMESH 2005/06/21 APPR:GGLLEE 2005/06/24	QUALITY SYMBOLS ▽=0 ▽C=0	GENERAL TOLERANCES (UNLESS SPECIFIED)		DIMENSION STYLE MM ONLY		SCALE NTS	DESIGN UNITS METRIC	THIRD ANGLE PROJECTION	
		mm	INCH	DRAWN BY SQUEK	DATE 2000/01/21	TITLE SALES DRAWING DIMM, 1.27MM PITCH 168 CKTS, R/A			
D1	REV	4 PLACES ± --- ± ---		APPROVED BY SKTOH		DATE 2000/03/03		MOLEX INCORPORATED	
		3 PLACES ± --- ± ---		DATE 2000/03/01		DOCUMENT NO. SD-87609-001		SHEET NO. 2 OF 3	
		2 PLACES ± 0.25 ± ---		MATERIAL NO.		DATE 2000/03/03		THIS DRAWING CONTAINS INFORMATION THAT IS PROPRIETARY TO MOLEX INCORPORATED AND SHOULD NOT BE USED WITHOUT WRITTEN PERMISSION	
		1 PLACE ± --- ± ---		SIZE A3					
		ANGULAR ± 5 °		DRAFT WHERE APPLICABLE MUST REMAIN WITHIN DIMENSIONS					

9 8 7 6 5 4 3 2 1

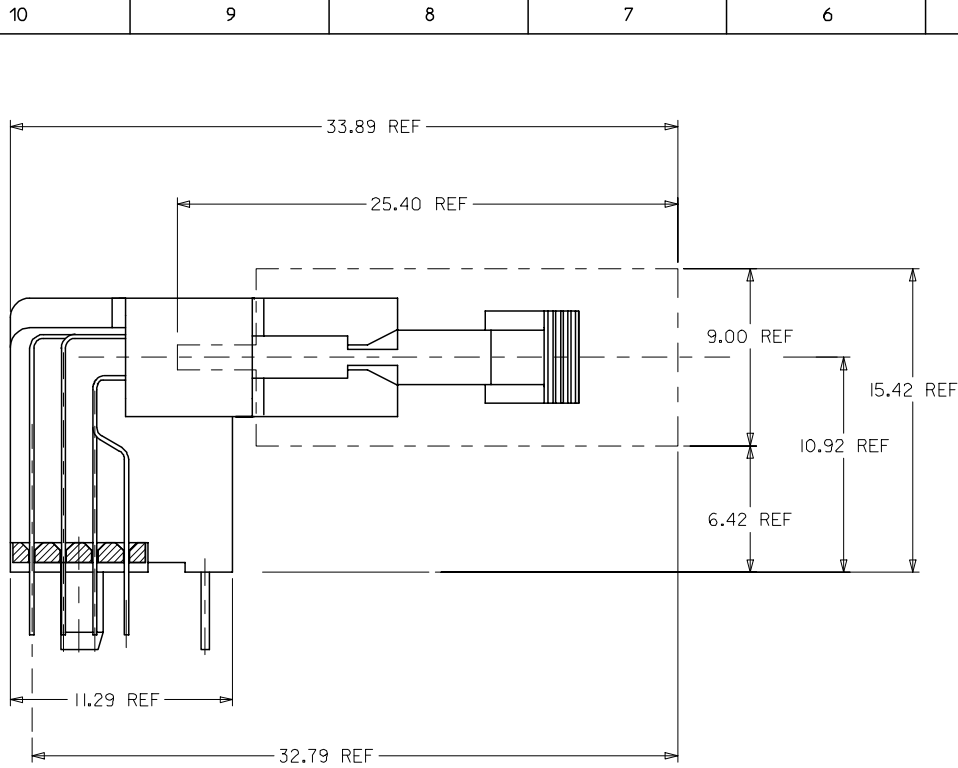

ACTUAL MODULE HEIGHT AND CLEARANCE
WHEN USING A 9.00MM THICK BY 25.40MM HEIGHT
MODULE (TYPICAL SOJ PACKAGING).

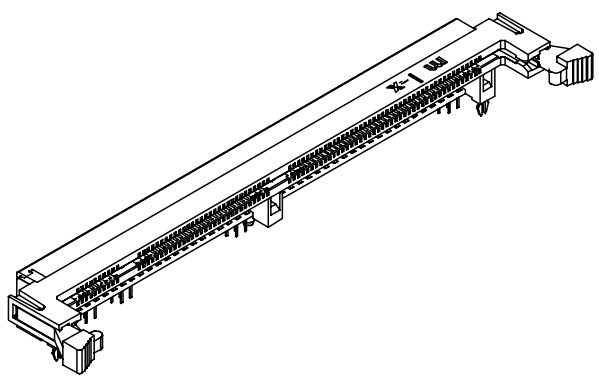

PLATING OPTION	MATERIAL NO.	FUNCTION KEY	GOLD PLATING OPTION AT CONTACT AREA	DATUM VOLTAGE KEY	TAIL LENGTH P±0.25
TIN/LEAD	87609-0048	LEFT	15µIN/(0.38µM) MIN.	CENTER (3.3V)	2.79
	87609-0049	CENTRE			
	87609-0050	RIGHT			
	87609-0148	LEFT	30µIN/(0.76µM) MIN.		
	87609-0149	CENTRE			
	87609-0150	RIGHT			
	87609-0057	LEFT	15µIN/(0.38µM) MIN.	CENTER (3.3V)	3.18
	87609-0058	CENTRE			
	87609-0059	RIGHT			
	87609-0157	LEFT	30µIN/(0.76µM) MIN.		
	87609-0158	CENTRE			
	87609-0159	RIGHT			
87609-0066	LEFT	15µIN/(0.38µM) MIN.	CENTER (3.3V)	3.56	
87609-0067	CENTRE				
87609-0068	RIGHT				
87609-0166	LEFT	30µIN/(0.76µM) MIN.			
87609-0167	CENTRE				
87609-0168	RIGHT				
TIN	87609-0051	LEFT	15µIN/(0.38µM) MIN.	CENTER (3.3V)	2.79
	87609-0052	CENTRE			
	87609-0053	RIGHT			
	87609-0151	LEFT	30µIN/(0.76µM) MIN.		
	87609-0152	CENTRE			
	87609-0153	RIGHT			
	87609-0060	LEFT	15µIN/(0.38µM) MIN.	CENTER (3.3V)	3.18
	87609-0061	CENTRE			
	87609-0062	RIGHT			
	87609-0160	LEFT	30µIN/(0.76µM) MIN.		
	87609-0161	CENTRE			
	87609-0162	RIGHT			
	87609-0069	LEFT	15µIN/(0.38µM) MIN.	CENTER (3.3V)	3.56
	87609-0070	CENTRE			
	87609-0071	RIGHT			
87609-0169	LEFT	30µIN/(0.76µM) MIN.			
87609-0170	CENTRE				
87609-0171	RIGHT				

ADD FLAMMABILITY RATING EC NO: S2005-0928 2005/06/16 DRWN:SHLENI 2005/06/21 CHKD:SRAMESH 2005/06/21 APPR:GGLEE 2005/06/24	QUALITY SYMBOLS ▽=0 ▽C=0	GENERAL TOLERANCES (UNLESS SPECIFIED)	DIMENSION STYLE MM ONLY	SCALE NTS	DESIGN UNITS METRIC	THIRD ANGLE PROJECTION	
		4 PLACES ± --- ± ---	DRAWN BY SQUEK	DATE 2000/01/21	SALES DRAWING DIMM, 1.27MM PITCH 168 CKTS, R/A MOLEX INCORPORATED		
		3 PLACES ± --- ± ---	CHECKED BY KCLING	DATE 2000/03/01			
		2 PLACES ± 0.25 ± ---	APPROVED BY SKTOH	DATE 2000/03/03			
1 PLACE ± --- ± ---	ANGULAR ± 5 °						
D1	REV	DRAFT WHERE APPLICABLE MUST REMAIN WITHIN DIMENSIONS	SIZE A3	MATERIAL NO. SEE TABLE	DOCUMENT NO. SD-87609-001	SHEET NO. 3 OF 3	