

Common mode Noise Filters

Type: **EXC24CE**
EXC24CF



■ Features

- Reduce the common mode noise and reform the signal wave by high-coupled inductors
- The strong multi-layer structure provides high resistance to reflow soldering heat and a high mounting reliability
- Magnetic shield type
- High-Q impedance : EXC24CF type is also available
- Small size and low-profile
(L 1.25 mm×W 1.00 mm×H 0.50 mm)

RoHS compliant

■ Recommended Applications

- USB data lines such as PCs, DSC, Mobile phone.
- LVDS data lines such as PCs, TV.
- IEEE1394 data lines such as PCs, TV.

■ Explanation of Part Numbers

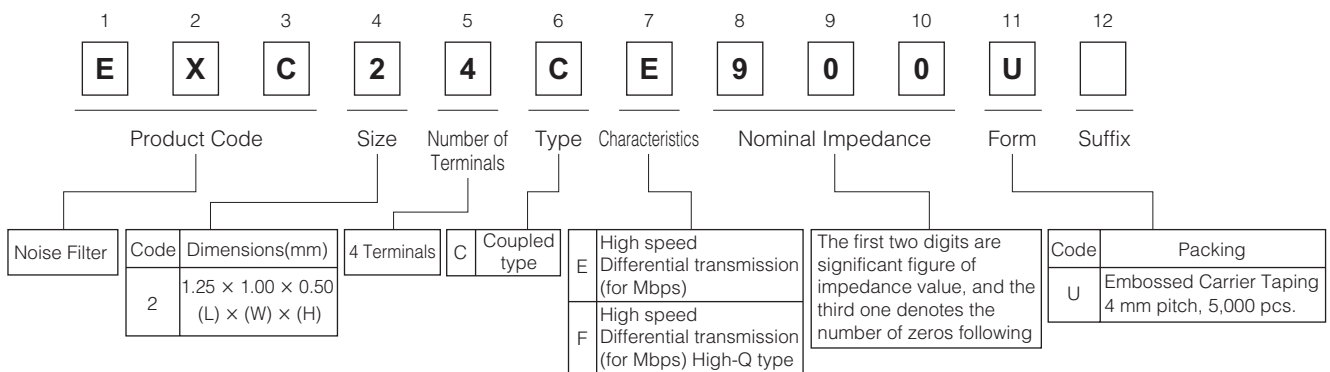

■ Construction

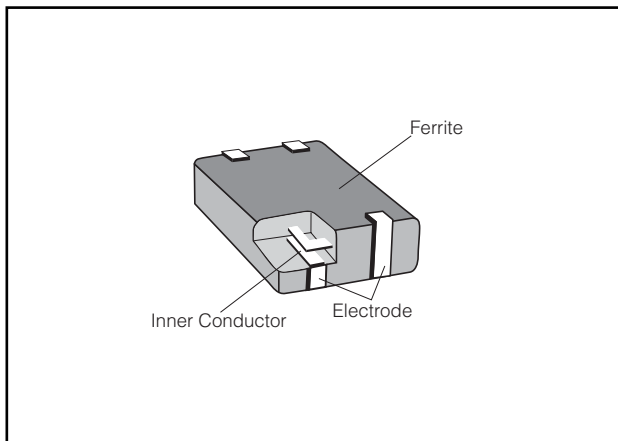

■ Dimensions in mm (not to scale)

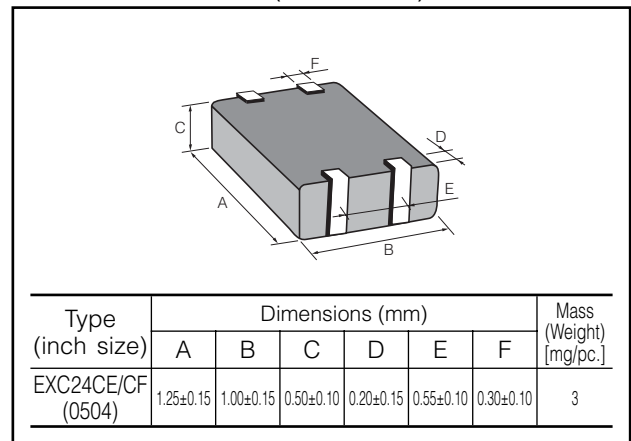

■ Circuit Configuration

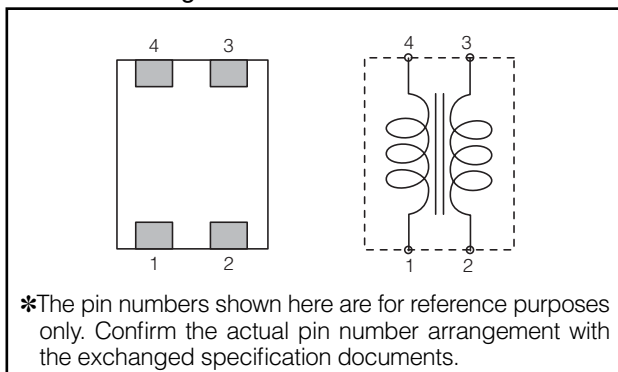

■ Ratings

Part Number	Impedance (Ω) at 100 MHz		Rated Voltage (V DC)	Rated Current (mA DC)	DC Resistance (Ω)max.
	Common Mode	Differential Mode			
EXC24CE360UP	36 $\Omega \pm 25\%$	20 Ω max.	5	200	1.00
EXC24CE900U	90 $\Omega \pm 25\%$	15 Ω max.	5	160	1.75
EXC24CE121U	120 $\Omega \pm 25\%$	18 Ω max.	5	140	2.20
EXC24CE201U	200 $\Omega \pm 25\%$	20 Ω max.	5	130	2.70
EXC24CF900U	90 $\Omega \pm 25\%$	20 Ω max.	5	130	2.50

■ Impedance Characteristics (Typical)

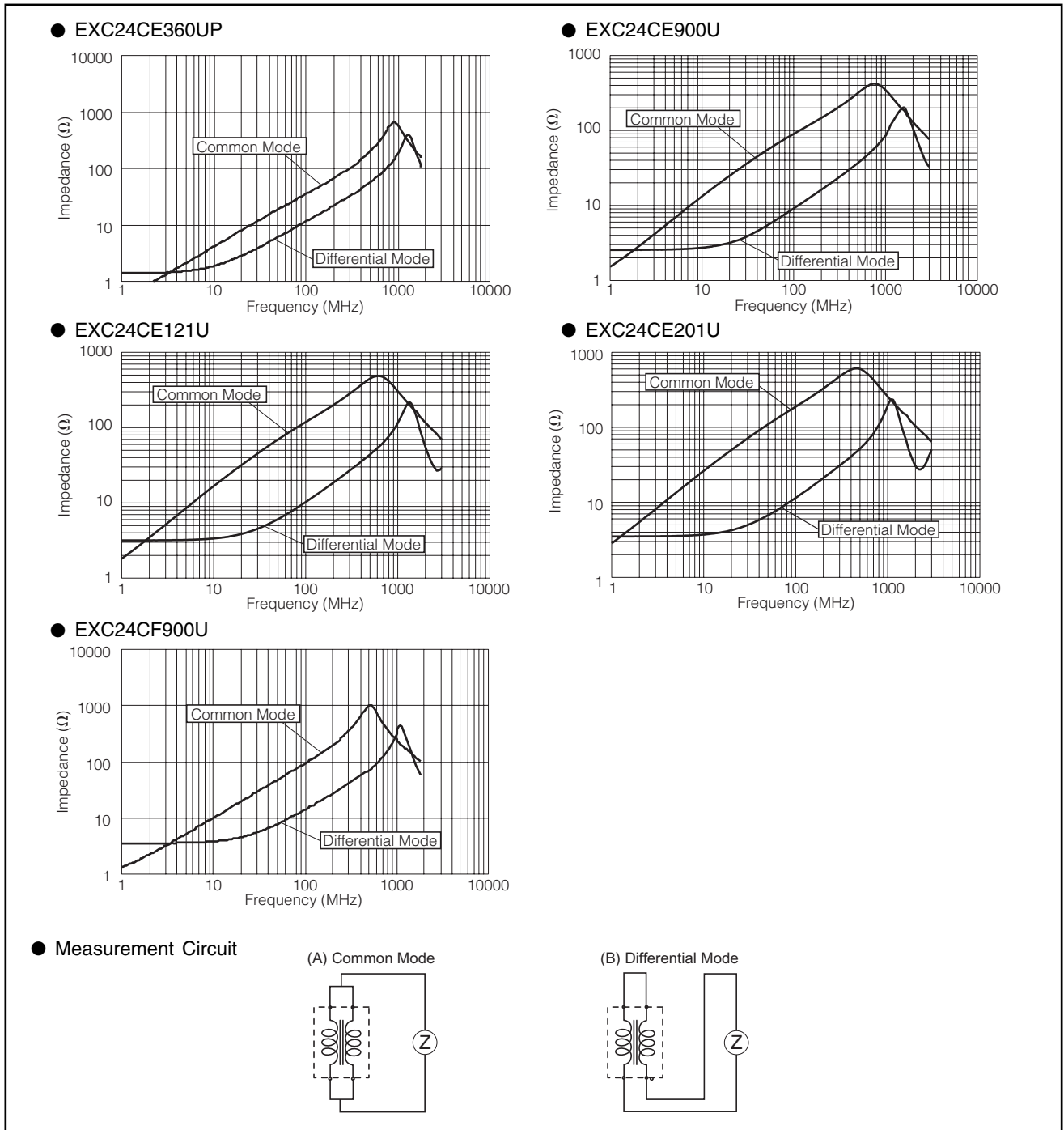

■ Packaging Methods

Please see Page 235

■ Recommended Land Pattern Design,

Recommended Soldering Conditions, \triangle Safety Precautions

Please see Page 236

Design and specifications are each subject to change without notice. Ask factory for the current technical specifications before purchase and/or use. Should a safety concern arise regarding this product, please be sure to contact us immediately.