

Customer Information Sheet

DRAWING No.: H3194-XX

SHEET 2 OF 2

IF IN DOUBT - ASK

©

NOT TO SCALE

THIRD ANGLE PROJECTION

ALL DIMENSIONS IN mm

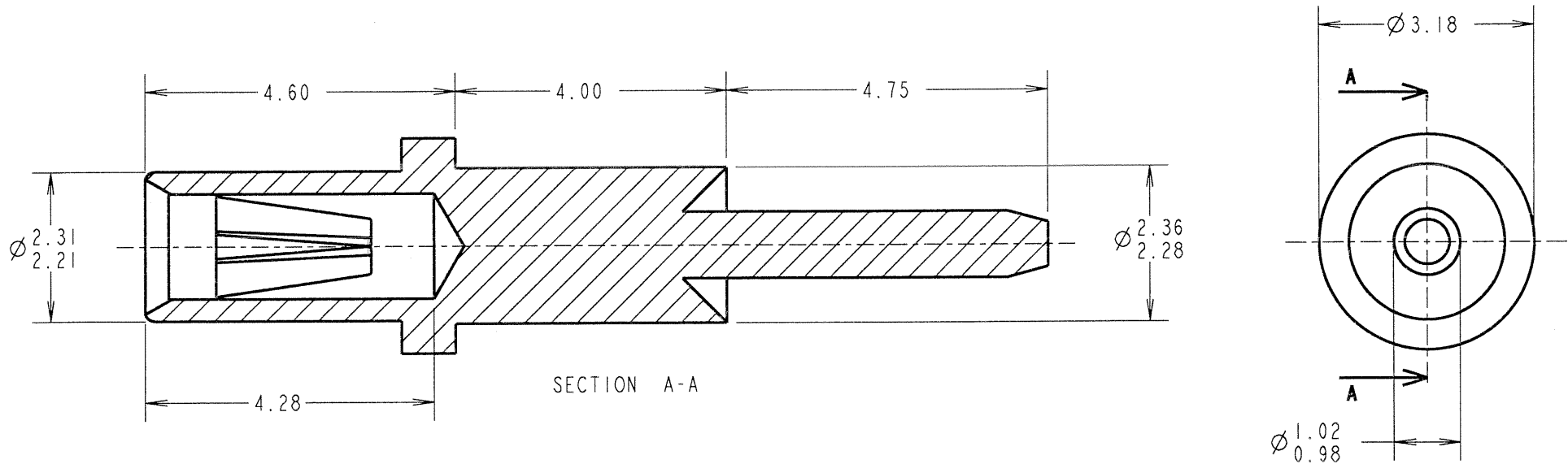

SPECIFICATION:

MATERIAL:

CONTACT SHELL = BRASS
CONTACT CLIP = BERYLLIUM COPPER

FINISH:

01 = 4µ TIN SHELL, 0.15µ GOLD CLIP
05 = 0.1µ GOLD SHELL, 0.15µ GOLD CLIP
46 = 4µ 100% TIN SHELL, 3µ 100% TIN CLIP

ELECTRICAL:

CURRENT RATING AT 25°C = 10A MAX
CURRENT RATING AT 85°C = 7.5A MAX
CONTACT RESISTANCE = 25 MILLIOHMS MAX

MECHANICAL:

INSERTION FORCE (∅1mm GAUGE) = 9N MAX, 3N MIN
WITHDRAWAL FORCE (∅1mm GAUGE) = 3N MAX, 1N MIN

DURABILITY:

01, 05 = 1000 OPERATIONS
46 = 100 OPERATIONS

ENVIRONMENTAL:

OPERATING TEMPERATURE = -40°C TO +105°C

NOTES:

- FOR COMPLETE SPECIFICATION, SEE COMPONENT SPECIFICATION C009XX (LATEST ISSUE).
- MAXIMUM CONTACT DEPTH = 3.55mm.
- RECOMMENDED MOUNTING HOLE SIZE = ∅2.47-2.37mm.
- RECOMMENDED PIN SIZE = ∅1.05-0.90mm.
- MAXIMUM PIN LENGTH = 4.50mm.

ORDER CODE:

H3194-XX

FINISH:

01 = TIN SHELL, GOLD CLIP
05 = GOLD SHELL, GOLD CLIP
46 = 100% TIN SHELL & TIN CLIP

JMB	7	09.03.06	9079
NAME	ISS.	DATE	C/NOTE
APPROVED: <i>[Signature]</i>			
CHECKED: <i>[Signature]</i>			
DRAWN:		I. SANDY	
CUSTOMER REF.:			
ASSEMBLY DRG.:			

HARWIN

THIS DRAWING AND ANY INFORMATION OR DESCRIPTIVE MATTER SET OUT HEREON ARE CONFIDENTIAL AND COPYRIGHT PROPERTY OF THE HARWIN GROUP AND MUST NOT BE DISCLOSED, LOANED, COPIED OR USED FOR MANUFACTURING, TENDERING OR FOR ANY OTHER PURPOSE WITHOUT THEIR WRITTEN PERMISSION.

TOLERANCES

X. = ±1mm
X.X = ±0.25mm
X.XX = ±0.10mm
X.XXX = ±0.01mm
ANGLES = ±5°
UNLESS STATED

MATERIAL:

SEE ABOVE

FINISH: SEE ABOVE

S/AREA:

mm²

TITLE:

∅1.00mm SOCKET ASSEMBLY

DRAWING NUMBER:

H3194-XX

SHT
2
OF
2

HARWIN INC
U.S.A.
TEL: (812) 542 2540
FAX: (812) 542 2541

HARWIN PLC
U.K.
TEL: 023 9231 4545
FAX: 023 9231 4590

HARWIN PTE
SINGAPORE
TEL: 65 6779 4909
FAX: 65 6779 3868