

FEATURES

- **Qualified for Automotive Applications**
- **Very Low Power Consumption**
– 1 mW Typ at $V_{DD} = 5\text{ V}$
- **Capable of Operation in Astable Mode**
- **CMOS Output Capable of Swinging Rail to Rail**
- **High Output-Current Capability**
– Sink 100 mA Typ
– Source 10 mA Typ
- **Output Fully Compatible With CMOS, TTL, and MOS**
- **Low Supply Current Reduces Spikes During Output Transitions**
- **Single-Supply Operation From 2 V to 15 V**
- **Functionally Interchangeable With the NE555; Has Same Pinout**

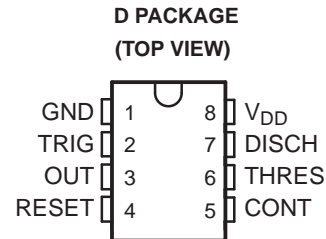

DESCRIPTION/ORDERING INFORMATION

The TLC555 is a monolithic timing circuit fabricated using the TI LinCMOS™ process. The timer is fully compatible with CMOS, TTL, and MOS logic and operates at frequencies up to 2 MHz. Because of its high input impedance, this device uses smaller timing capacitors than those used by the NE555. As a result, more accurate time delays and oscillations are possible. Power consumption is low across the full range of power supply voltage.

Like the NE555, the TLC555 has a trigger level equal to approximately one-third of the supply voltage and a threshold level equal to approximately two-thirds of the supply voltage. These levels can be altered by use of the control voltage terminal (CONT). When the trigger input (TRIG) falls below the trigger level, the flip-flop is set and the output goes high. If TRIG is above the trigger level and the threshold input (THRES) is above the threshold level, the flip-flop is reset and the output is low. The reset input (RESET) can override all other inputs and can be used to initiate a new timing cycle. If RESET is low, the flip-flop is reset and the output is low. Whenever the output is low, a low-impedance path is provided between the discharge terminal (DISCH) and GND. All unused inputs should be tied to an appropriate logic level to prevent false triggering.

While the CMOS output is capable of sinking over 100 mA and sourcing over 10 mA, the TLC555 exhibits greatly reduced supply-current spikes during output transitions. This minimizes the need for the large decoupling capacitors required by the NE555.

The TLC555 is characterized for operation over the full automotive temperature range of -40°C to 125°C .

ORDERING INFORMATION⁽¹⁾

T_A	V_{DD}	PACKAGE ⁽²⁾		ORDERABLE PART NUMBER	TOP-SIDE MARKING
-40°C to 125°C	5 V to 15 V	SOIC – D	Reel of 2500	TLC555QDRQ1	TLC555Q

- (1) For the most current package and ordering information, see the Package Option Addendum at the end of this document, or see the TI web site at www.ti.com.
- (2) Package drawings, standard packing quantities, thermal data, symbolization, and PCB design guidelines are available at www.ti.com/sc/package.



Please be aware that an important notice concerning availability, standard warranty, and use in critical applications of Texas Instruments semiconductor products and disclaimers thereto appears at the end of this data sheet.

LinCMOS is a trademark of Texas Instruments.

FUNCTION TABLE

RESET VOLTAGE ⁽¹⁾	TRIGGER VOLTAGE ⁽¹⁾	THRESHOLD VOLTAGE ⁽¹⁾	OUTPUT	DISCHARGE SWITCH
<MIN	Irrelevant	Irrelevant	L	On
>MAX	<MIN	Irrelevant	H	Off
>MAX	>MAX	>MAX	L	On
>MAX	>MAX	<MIN	As previously established	

(1) For conditions shown as MIN or MAX, use the appropriate value specified under electrical characteristics.

FUNCTIONAL BLOCK DIAGRAM

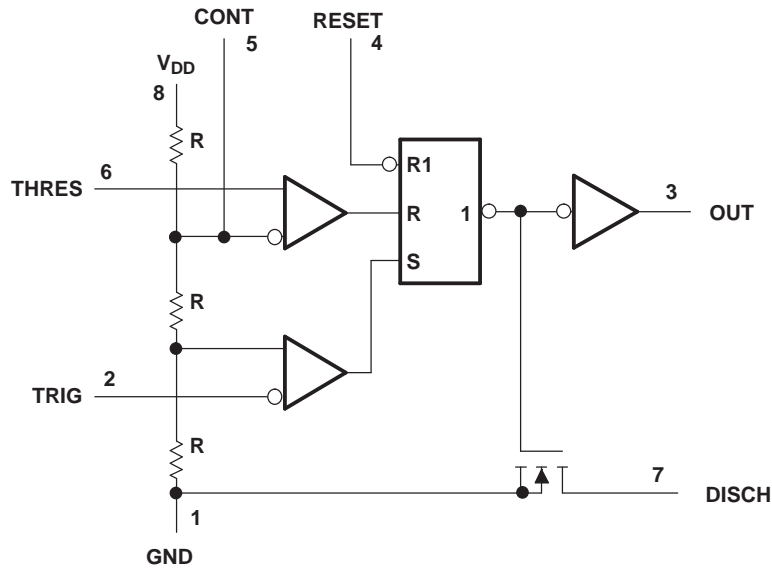

A. RESET can override TRIG, which can override THRES.

EQUIVALENT SCHEMATIC

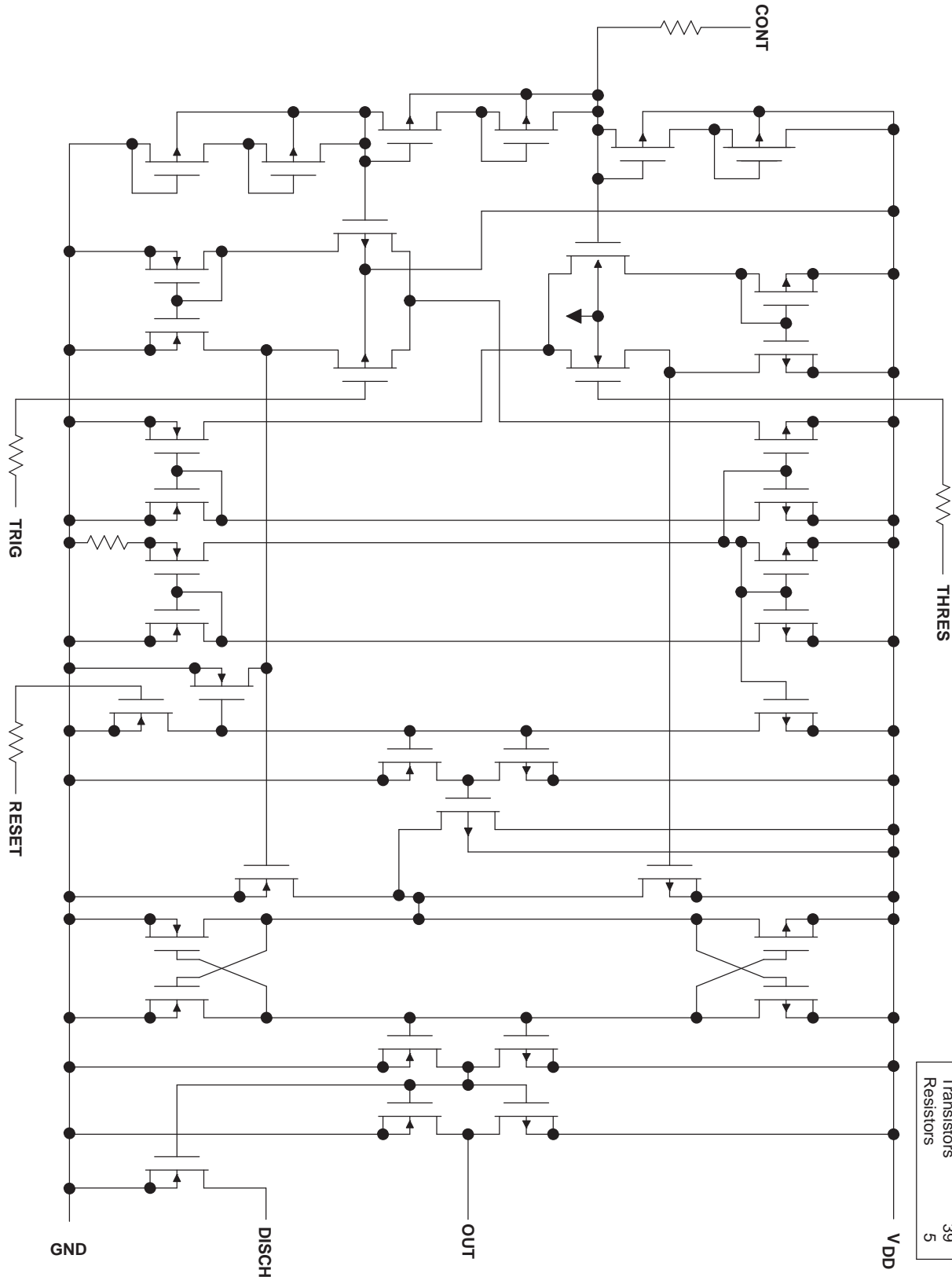

COMPONENT COUNT	
Transistors	39
Resistors	5

Absolute Maximum Ratings⁽¹⁾

over operating free-air temperature range (unless otherwise noted)

		MIN	MAX	UNIT
V _{DD}	Supply voltage ⁽²⁾		18	V
V _I	Input voltage range	Any input	-0.3	V _{DD}
	Sink current, discharge or output		150	mA
I _O	Source current, output		15	mA
	Continuous total power dissipation	See Dissipation Rating Table		
T _A	Operating free-air temperature range	-40	125	°C
T _{stg}	Storage temperature range	-65	150	°C
	Lead temperature	1,6 mm (1/16 ch) from case for 10 s	260	°C
	HBM (Human Body Model) ESD		1000	V

- (1) Stresses beyond those listed under "absolute maximum ratings" may cause permanent damage to the device. These are stress ratings only and functional operation of the device at these or any other conditions beyond those indicated under "recommended operating conditions" is not implied. Exposure to absolute-maximum-rated conditions for extended periods may affect device reliability.
- (2) All voltage values are with respect to network GND.

Dissipation Ratings

PACKAGE	T _A ≤ 25°C POWER RATING	DERATING FACTOR ABOVE T _A = 25°C	T _A = 125°C POWER RATING
D	725 mW	5.8 mW/°C	145 mW

Recommended Operating Conditions

		MIN	MAX	UNIT
V _{DD}	Supply voltage	2	15	V
T _A	Operating free-air temperature	-40	125	°C

Electrical Characteristics

$V_{DD} = 5\text{ V}$, at specified free-air temperature (unless otherwise noted)

PARAMETER		TEST CONDITIONS	T_A (1)	MIN	TYP	MAX	UNIT
V_{IT}	Threshold voltage		25°C	2.8	3.3	3.8	V
			Full range	2.7		3.9	
I_{IT}	Threshold current		25°C	10			pA
			MAX	5000			
$V_{I(TRIG)}$	Trigger voltage		25°C	1.36	1.66	1.96	V
			Full range	1.26		2.06	
$I_{I(TRIG)}$	Trigger current		25°C	10			pA
			MAX	5000			
$V_{I(RESET)}$	Reset voltage		25°C	0.4	1.1	1.5	V
			Full range	0.3		1.8	
$I_{I(RESET)}$	Reset current		25°C	10			pA
			MAX	5000			
	Control voltage (open circuit) as a percentage of supply voltage		MAX	66.7			%
	Discharge switch on-state voltage	$I_{OL} = 10\text{ mA}$	25°C		0.14	0.5	V
			Full range			0.6	
	Discharge switch off-state current		25°C	0.1			nA
			MAX	120			
V_{OH}	High-level output voltage	$I_{OH} = -1\text{ mA}$	25°C	4.1	4.8		V
			Full range	4.1			
V_{OL}	Low-level output voltage	$I_{OL} = 8\text{ mA}$	25°C		0.21	0.4	V
			Full range			0.6	
		$I_{OL} = 5\text{ mA}$	25°C		0.13	0.3	
			Full range			0.45	
		$I_{OL} = 3.2\text{ mA}$	25°C		0.08	0.3	
			Full range			0.4	
I_{DD}	Supply current (2)		25°C		170	350	μA
			Full range			700	

(1) Full range T_A is -40°C to 125°C .

(2) These values apply for the expected operating configurations in which THRES is connected directly to DISCH or TRIG.

Electrical Characteristics

$V_{DD} = 15\text{ V}$, at specified free-air temperature (unless otherwise noted)

PARAMETER		TEST CONDITIONS	T_A (1)	MIN	TYP	MAX	UNIT
V_{IT}	Threshold voltage		25°C	9.45	10	10.55	V
			Full range	9.35		10.65	
I_{IT}	Threshold current		25°C		10		pA
			MAX		5000		
$V_{I(TRIG)}$	Trigger voltage		25°C	4.65	5	5.35	V
			Full range	4.55		5.45	
$I_{I(TRIG)}$	Trigger current		25°C		10		pA
			MAX		5000		
$V_{I(RESET)}$	Reset voltage		25°C	0.4	1.1	1.5	V
			Full range	0.3		1.8	
$I_{I(RESET)}$	Reset current		25°C		10		pA
			MAX		5000		
	Control voltage (open circuit) as a percentage of supply voltage		MAX		66.7		%
	Discharge switch on-state voltage	$I_{OL} = 100\text{ mA}$	25°C		0.77	1.7	V
			Full range			1.8	
	Discharge switch off-state current		25°C		0.1		nA
			MAX		120		
V_{OH}	High-level output voltage	$I_{OH} = -10\text{ mA}$	25°C	12.5	14.2		V
			Full range	12.5			
		$I_{OH} = -5\text{ mA}$	25°C	13.5	14.6		
			Full range	13.5			
		$I_{OH} = -1\text{ mA}$	25°C	14.2	14.9		
			Full range	14.2			
V_{OL}	Low-level output voltage	$I_{OL} = 100\text{ mA}$	25°C		1.28	3.2	V
			Full range			3.8	
		$I_{OL} = 50\text{ mA}$	25°C		0.63	1	
			Full range			1.5	
		$I_{OL} = 10\text{ mA}$	25°C		0.12	0.3	
			Full range			0.45	
I_{DD}	Supply current(2)		25°C		360	600	μA
			Full range			1000	

(1) Full range T_A is -40°C to 125°C .

(2) These values apply for the expected operating configurations in which THRES is connected directly to DISCH or TRIG.

Operating Characteristics

$V_{DD} = 5\text{ V}$, $T_A = 25^\circ\text{C}$ (unless otherwise noted)

PARAMETER		TEST CONDITIONS	MIN	TYP	MAX	UNIT
	Initial error of timing interval ⁽¹⁾	$V_{DD} = 5\text{ V to }15\text{ V}$, $C_T = 0.1\ \mu\text{F}$, $R_A = R_B = 1\ \text{k}\Omega\text{ to }100\ \text{k}\Omega^{(2)}$		1	3	%
	Supply voltage sensitivity of timing interval	$V_{DD} = 5\text{ V to }15\text{ V}$, $C_T = 0.1\ \mu\text{F}$, $R_A = R_B = 1\ \text{k}\Omega\text{ to }100\ \text{k}\Omega^{(2)}$		0.1	0.5	%/V
t_r	Output pulse rise time	$R_L = 10\ \text{M}\Omega$, $C_L = 10\ \text{pF}$		20	75	ns
t_f	Output pulse fall time	$R_L = 10\ \text{M}\Omega$, $C_L = 10\ \text{pF}$		15	60	ns
f_{max}	Maximum frequency in astable mode	$R_A = 470\ \Omega$, $C_T = 200\ \text{pF}$, $R_B = 200\ \Omega^{(2)}$	1.2	2.1		MHz

- (1) Timing interval error is defined as the difference between the measured value and the average value of a random sample from each process run.
 (2) R_A , R_B , and C_T are as defined in [Figure 1](#).

Electrical Characteristics

$V_{DD} = 5\text{ V}$, $T_A = 25^\circ\text{C}$ (unless otherwise noted)

PARAMETER		TEST CONDITIONS	MIN	TYP	MAX	UNIT
V_{IT}	Threshold voltage		2.8	3.3	3.8	V
I_{IT}	Threshold current			10		pA
$V_{I(\text{TRIG})}$	Trigger voltage		1.36	1.66	1.96	V
$I_{I(\text{TRIG})}$	Trigger current			10		pA
$V_{I(\text{RESET})}$	Reset voltage		0.4	1.1	1.5	V
$I_{I(\text{RESET})}$	Reset current			10		pA
	Control voltage (open circuit) as a percentage of supply voltage			66.7		%
	Discharge switch on-state voltage	$I_{OL} = 10\ \text{mA}$		0.14	0.5	V
	Discharge switch off-state current			0.1		nA
V_{OH}	High-level output voltage	$I_{OH} = -1\ \text{mA}$	4.1	4.8		V
V_{OL}	Low-level output voltage	$I_{OL} = 8\ \text{mA}$		0.21	0.4	V
		$I_{OL} = 5\ \text{mA}$		0.13	0.3	
		$I_{OL} = 3.2\ \text{mA}$		0.08	0.3	
I_{DD}	Supply current ⁽¹⁾			170	350	μA

- (1) These values apply for the expected operating configurations in which THRES is connected directly to DISCH or TRIG.

TYPICAL CHARACTERISTICS
DISCHARGE SWITCH ON-STATE RESISTANCE
vs
FREE-AIR TEMPERATURE

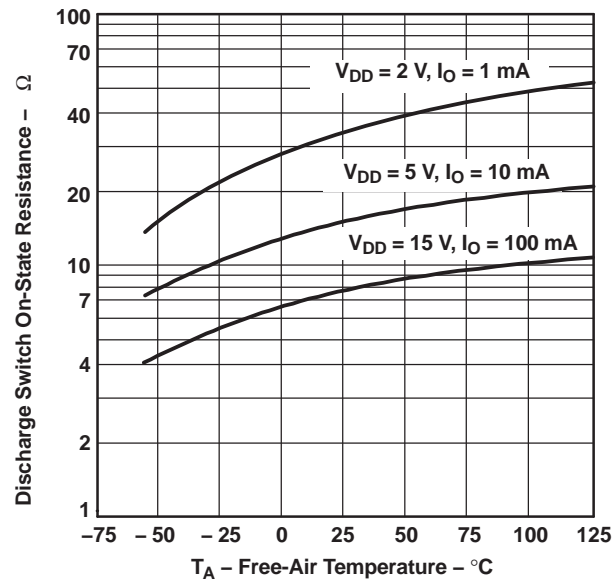
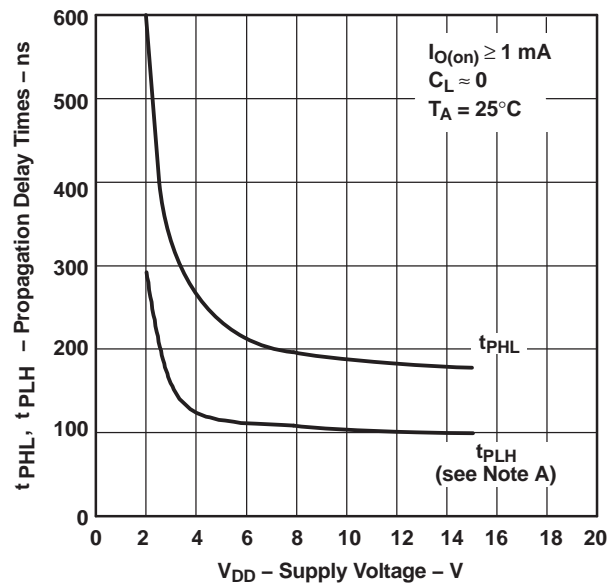

Figure 1.

PROPAGATION DELAY TIMES TO DISCHARGE
OUTPUT FROM TRIGGER AND THRESHOLD
SHORTED TOGETHER
vs
SUPPLY VOLTAGE



A. The effects of the load resistance on these values must be taken into account separately.

Figure 2.

APPLICATION INFORMATION

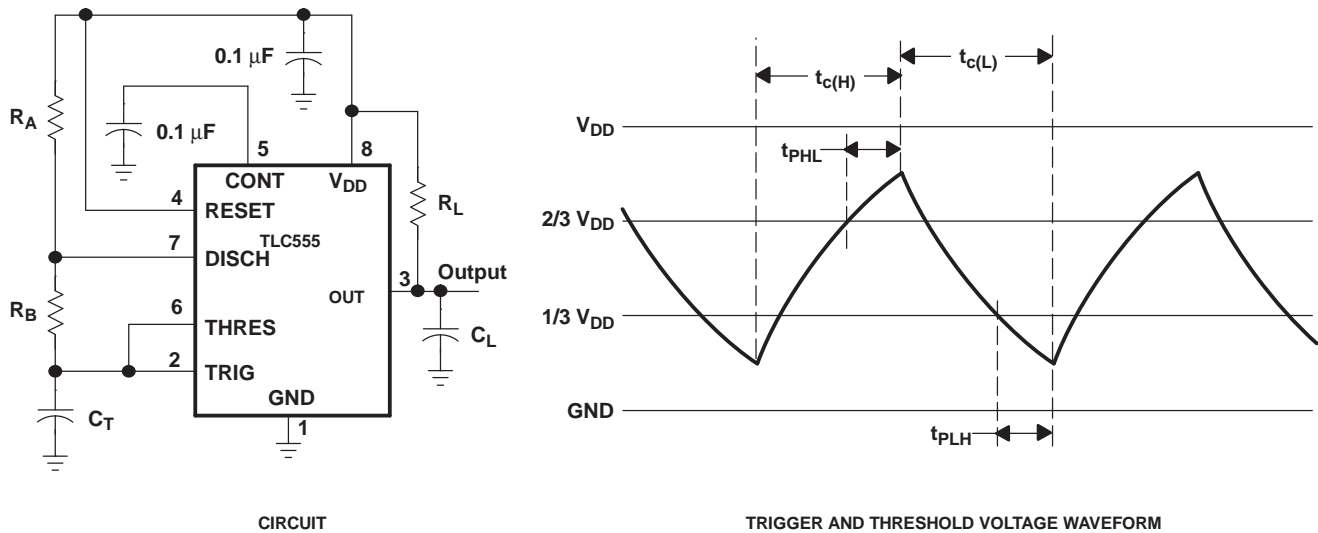

Figure 3. Astable Operation

Connecting TRIG to THRES, as shown in [Figure 3](#), causes the timer to run as a multivibrator. The capacitor C_T charges through R_A and R_B to the threshold voltage level (approximately $0.67 V_{DD}$) and then discharges through R_B only to the value of the trigger voltage level (approximately $0.33 V_{DD}$). The output is high during the charging cycle ($t_{c(H)}$) and low during the discharge cycle ($t_{c(L)}$). The duty cycle is controlled by the values of R_A , R_B , and C_T as shown in the following equations.

$$t_{c(H)} \approx C_T (R_A + R_B) \ln 2 \quad (\ln 2 = 0.693)$$

$$t_{c(L)} \approx C_T R_B \ln 2$$

$$\text{Period} = t_{c(H)} + t_{c(L)} \approx C_T (R_A + 2R_B) \ln 2$$

$$\text{Output driver duty cycle} = \frac{t_{c(L)}}{t_{c(H)} + t_{c(L)}} \approx 1 - \frac{R_B}{R_A + 2R_B}$$

$$\text{Output waveform duty cycle} = \frac{t_{c(H)}}{t_{c(H)} + t_{c(L)}} \approx \frac{R_B}{R_A + 2R_B}$$

The 0.1- μF capacitor at CONT in [Figure 3](#) decreases the period by about 10%.

The formulas shown above do not allow for any propagation delay times from the TRIG and THRES inputs to DISCH. These delay times add directly to the period and create differences between calculated and actual values that increase with frequency. In addition, the internal on-state resistance (r_{on}) during discharge adds to R_B to provide another source of timing error in the calculation when R_B is very low or r_{on} is very high.

APPLICATION INFORMATION (continued)

The following equations provide better agreement with measured values.

$$t_{c(H)} = C_T (R_A + R_B) \ln \left[3 - \exp \left(\frac{-t_{PLH}}{C_T (R_B + r_{on})} \right) \right] + t_{PHL}$$

$$t_{c(L)} = C_T (R_B + r_{on}) \ln \left[3 - \exp \left(\frac{-t_{PHL}}{C_T (R_A + R_B)} \right) \right] + t_{PLH}$$

These equations and those given previously are similar in that a time constant is multiplied by the logarithm of a number or function. The limit values of the logarithmic terms must be between $\ln 2$ at low frequencies and $\ln 3$ at extremely high frequencies. For a duty cycle close to 50%, an appropriate constant for the logarithmic terms

can be substituted with good results. Duty cycles less than 50% $\frac{t_{c(H)}}{t_{c(H)} + t_{c(L)}}$ require that $\frac{t_{c(H)}}{t_{c(L)}} < 1$ and possibly $R_A \leq r_{on}$. These conditions can be difficult to obtain.

In monostable applications, the trip point on TRIG can be set by a voltage applied to CONT. An input voltage between 10% and 80% of the supply voltage from a resistor divider with at least 500- μ A bias provides good results.

PACKAGING INFORMATION

Orderable Device	Status ⁽¹⁾	Package Type	Package Drawing	Pins	Package Qty	Eco Plan ⁽²⁾	Lead/Ball Finish	MSL Peak Temp ⁽³⁾
TLC555QDRQ1	ACTIVE	SOIC	D	8	2500	Green (RoHS & no Sb/Br)	CU NIPDAU	Level-1-260C-UNLIM

⁽¹⁾ The marketing status values are defined as follows:

ACTIVE: Product device recommended for new designs.

LIFEBUY: TI has announced that the device will be discontinued, and a lifetime-buy period is in effect.

NRND: Not recommended for new designs. Device is in production to support existing customers, but TI does not recommend using this part in a new design.

PREVIEW: Device has been announced but is not in production. Samples may or may not be available.

OBSOLETE: TI has discontinued the production of the device.

⁽²⁾ Eco Plan - The planned eco-friendly classification: Pb-Free (RoHS), Pb-Free (RoHS Exempt), or Green (RoHS & no Sb/Br) - please check <http://www.ti.com/productcontent> for the latest availability information and additional product content details.

TBD: The Pb-Free/Green conversion plan has not been defined.

Pb-Free (RoHS): TI's terms "Lead-Free" or "Pb-Free" mean semiconductor products that are compatible with the current RoHS requirements for all 6 substances, including the requirement that lead not exceed 0.1% by weight in homogeneous materials. Where designed to be soldered at high temperatures, TI Pb-Free products are suitable for use in specified lead-free processes.

Pb-Free (RoHS Exempt): This component has a RoHS exemption for either 1) lead-based flip-chip solder bumps used between the die and package, or 2) lead-based die adhesive used between the die and leadframe. The component is otherwise considered Pb-Free (RoHS compatible) as defined above.

Green (RoHS & no Sb/Br): TI defines "Green" to mean Pb-Free (RoHS compatible), and free of Bromine (Br) and Antimony (Sb) based flame retardants (Br or Sb do not exceed 0.1% by weight in homogeneous material)

⁽³⁾ MSL, Peak Temp. -- The Moisture Sensitivity Level rating according to the JEDEC industry standard classifications, and peak solder temperature.

Important Information and Disclaimer:The information provided on this page represents TI's knowledge and belief as of the date that it is provided. TI bases its knowledge and belief on information provided by third parties, and makes no representation or warranty as to the accuracy of such information. Efforts are underway to better integrate information from third parties. TI has taken and continues to take reasonable steps to provide representative and accurate information but may not have conducted destructive testing or chemical analysis on incoming materials and chemicals. TI and TI suppliers consider certain information to be proprietary, and thus CAS numbers and other limited information may not be available for release.

In no event shall TI's liability arising out of such information exceed the total purchase price of the TI part(s) at issue in this document sold by TI to Customer on an annual basis.

OTHER QUALIFIED VERSIONS OF TLC555-Q1 :

- Catalog: [TLC555](#)
- Military: [TLC555M](#)

NOTE: Qualified Version Definitions:

- Catalog - TI's standard catalog product
- Military - QML certified for Military and Defense Applications

D (R-PDSO-G8)

PLASTIC SMALL-OUTLINE PACKAGE

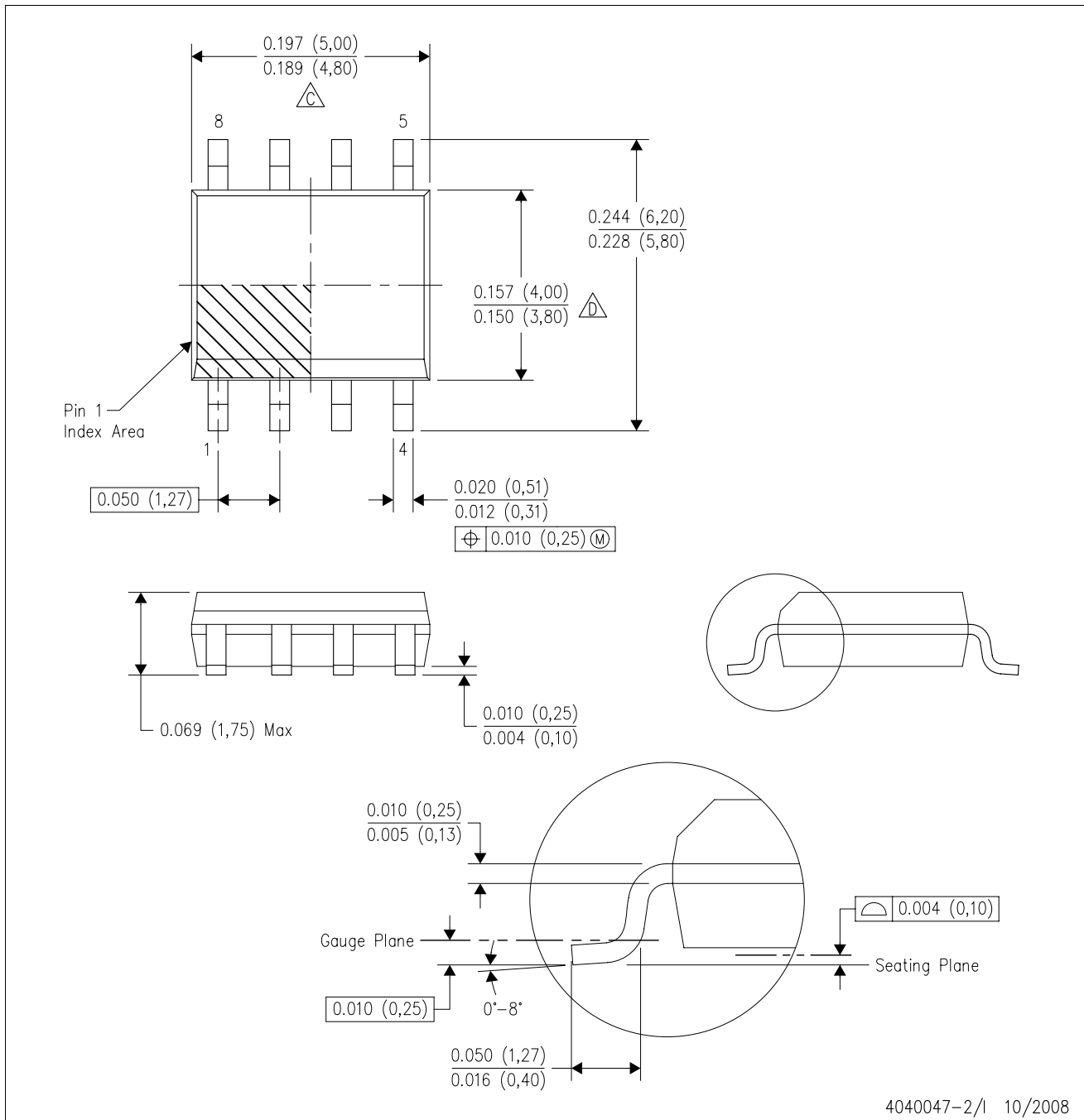

- NOTES:
- A. All linear dimensions are in inches (millimeters).
 - B. This drawing is subject to change without notice.
 - C. Body length does not include mold flash, protrusions, or gate burrs. Mold flash, protrusions, or gate burrs shall not exceed .006 (0,15) per end.
 - D. Body width does not include interlead flash. Interlead flash shall not exceed .017 (0,43) per side.
 - E. Reference JEDEC MS-012 variation AA.

IMPORTANT NOTICE

Texas Instruments Incorporated and its subsidiaries (TI) reserve the right to make corrections, modifications, enhancements, improvements, and other changes to its products and services at any time and to discontinue any product or service without notice. Customers should obtain the latest relevant information before placing orders and should verify that such information is current and complete. All products are sold subject to TI's terms and conditions of sale supplied at the time of order acknowledgment.

TI warrants performance of its hardware products to the specifications applicable at the time of sale in accordance with TI's standard warranty. Testing and other quality control techniques are used to the extent TI deems necessary to support this warranty. Except where mandated by government requirements, testing of all parameters of each product is not necessarily performed.

TI assumes no liability for applications assistance or customer product design. Customers are responsible for their products and applications using TI components. To minimize the risks associated with customer products and applications, customers should provide adequate design and operating safeguards.

TI does not warrant or represent that any license, either express or implied, is granted under any TI patent right, copyright, mask work right, or other TI intellectual property right relating to any combination, machine, or process in which TI products or services are used. Information published by TI regarding third-party products or services does not constitute a license from TI to use such products or services or a warranty or endorsement thereof. Use of such information may require a license from a third party under the patents or other intellectual property of the third party, or a license from TI under the patents or other intellectual property of TI.

Reproduction of TI information in TI data books or data sheets is permissible only if reproduction is without alteration and is accompanied by all associated warranties, conditions, limitations, and notices. Reproduction of this information with alteration is an unfair and deceptive business practice. TI is not responsible or liable for such altered documentation. Information of third parties may be subject to additional restrictions.

Resale of TI products or services with statements different from or beyond the parameters stated by TI for that product or service voids all express and any implied warranties for the associated TI product or service and is an unfair and deceptive business practice. TI is not responsible or liable for any such statements.

TI products are not authorized for use in safety-critical applications (such as life support) where a failure of the TI product would reasonably be expected to cause severe personal injury or death, unless officers of the parties have executed an agreement specifically governing such use. Buyers represent that they have all necessary expertise in the safety and regulatory ramifications of their applications, and acknowledge and agree that they are solely responsible for all legal, regulatory and safety-related requirements concerning their products and any use of TI products in such safety-critical applications, notwithstanding any applications-related information or support that may be provided by TI. Further, Buyers must fully indemnify TI and its representatives against any damages arising out of the use of TI products in such safety-critical applications.

TI products are neither designed nor intended for use in military/aerospace applications or environments unless the TI products are specifically designated by TI as military-grade or "enhanced plastic." Only products designated by TI as military-grade meet military specifications. Buyers acknowledge and agree that any such use of TI products which TI has not designated as military-grade is solely at the Buyer's risk, and that they are solely responsible for compliance with all legal and regulatory requirements in connection with such use.

TI products are neither designed nor intended for use in automotive applications or environments unless the specific TI products are designated by TI as compliant with ISO/TS 16949 requirements. Buyers acknowledge and agree that, if they use any non-designated products in automotive applications, TI will not be responsible for any failure to meet such requirements.

Following are URLs where you can obtain information on other Texas Instruments products and application solutions:

Products

Amplifiers	amplifier.ti.com
Data Converters	dataconverter.ti.com
DSP	dsp.ti.com
Clocks and Timers	www.ti.com/clocks
Interface	interface.ti.com
Logic	logic.ti.com
Power Mgmt	power.ti.com
Microcontrollers	microcontroller.ti.com
RFID	www.ti-rfid.com
RF/IF and ZigBee® Solutions	www.ti.com/lprf

Applications

Audio	www.ti.com/audio
Automotive	www.ti.com/automotive
Broadband	www.ti.com/broadband
Digital Control	www.ti.com/digitalcontrol
Medical	www.ti.com/medical
Military	www.ti.com/military
Optical Networking	www.ti.com/opticalnetwork
Security	www.ti.com/security
Telephony	www.ti.com/telephony
Video & Imaging	www.ti.com/video
Wireless	www.ti.com/wireless

Mailing Address: Texas Instruments, Post Office Box 655303, Dallas, Texas 75265
Copyright © 2008, Texas Instruments Incorporated