

PRODUCT NO.
SEE TABLE

A

B

C

D

A

B

C

D

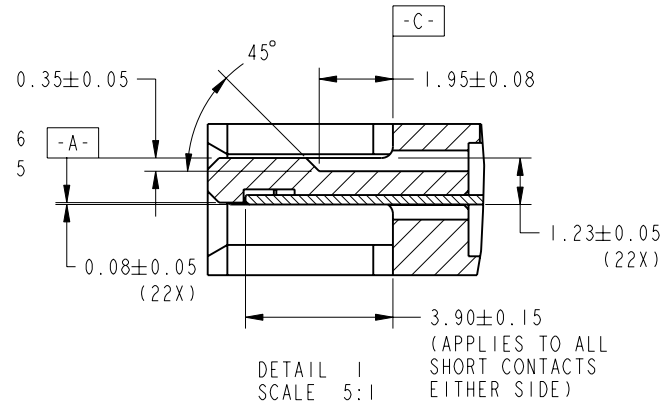
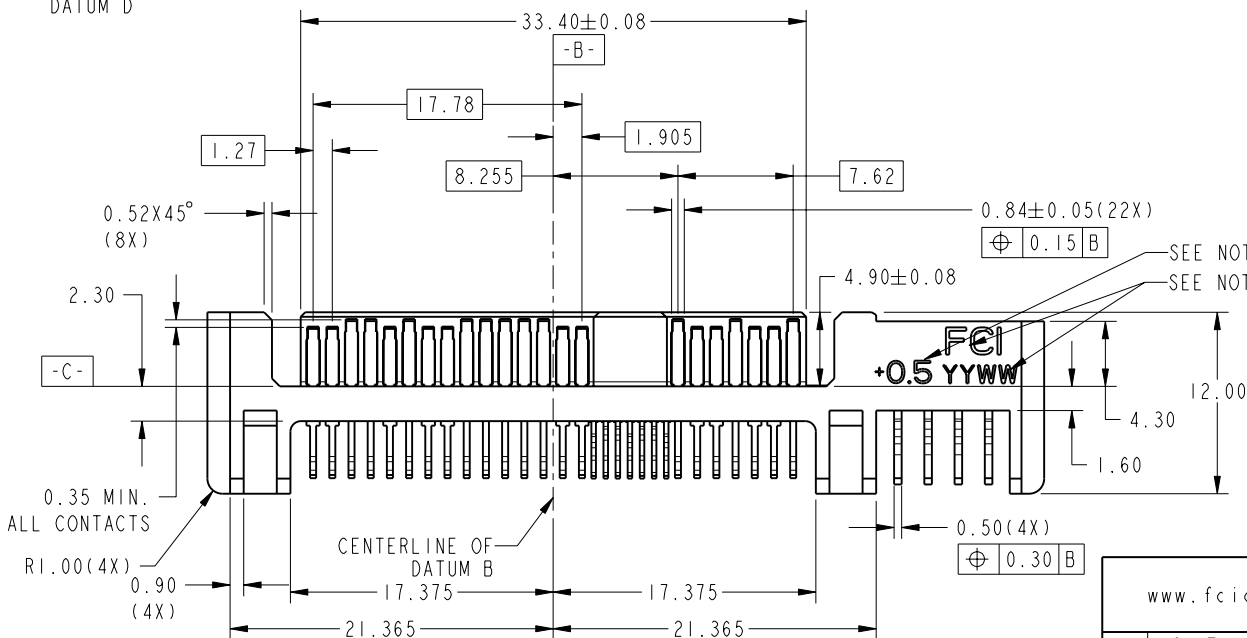
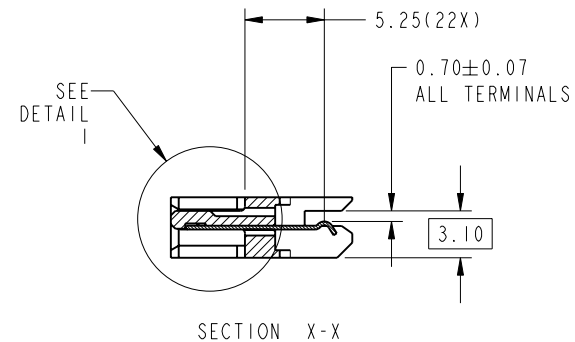
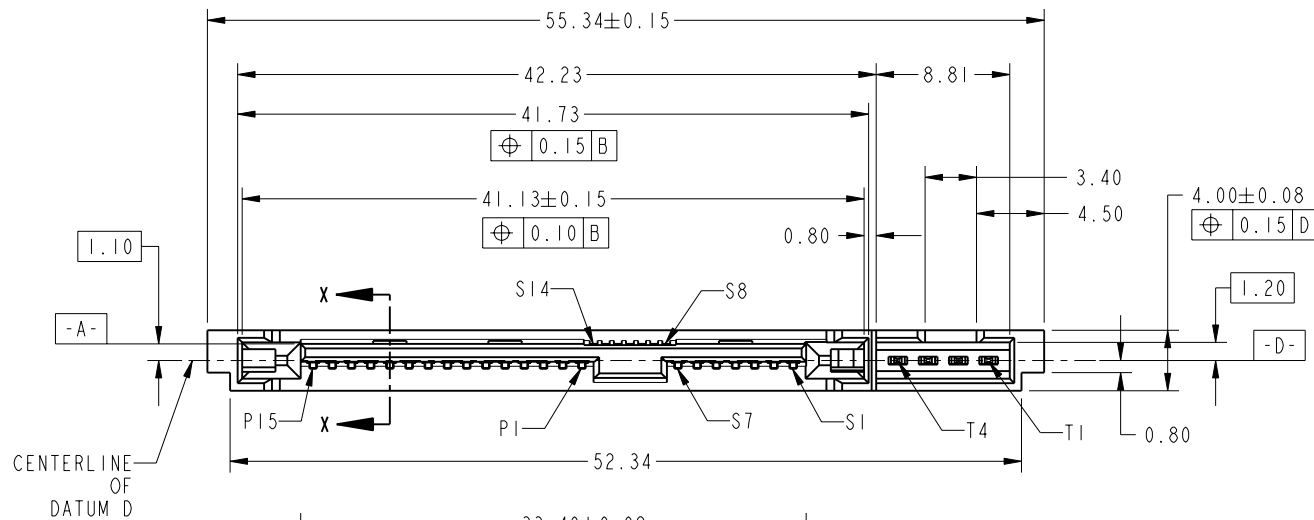

Copyright FCI

rev	ecn no	dr	date
A	S03-0108	JLIM	2003-07-28
B	S04-0228	SHT	2004-10-27
C	S04-0266	SHT	2004-12-14
D	S05-0093	SHT	2005-03-23
E	S06-0339	HKL	2006-10-09
-	-	-	-
-	-	-	-

www.fciconnect.com		surface	tolerance std	projection	MM
		✓	ASME Y14.5	⊕	←→
		TOLERANCES UNLESS OTHERWISE SPECIFIED		size	Scale
Dr	JONATHAN LIM	2003-07-28	ANGULAR	A4	2:1
Eng	HK LIM	2006-10-09	LINEAR	ECN	S06-0339
Chr	HK LIM	2006-10-09	0° ±2°	Product family	Spec ref
Appr	JOEY NG	2006-10-09	0.X ±0.25		
			0.XX ±0.13		
			0.XXX ±0.050		
FCI		SAS PLUG CONNECTOR		dwg no	10023060
catalog no		CUSTOMER		Rev.	E
				sheet 1 of 4	

REV E - 2006-03-28

2

PDM: Rev:E

STATUS:Released

4 Printed: Jan 24, 2007

PRODUCT NO.
SEE TABLE

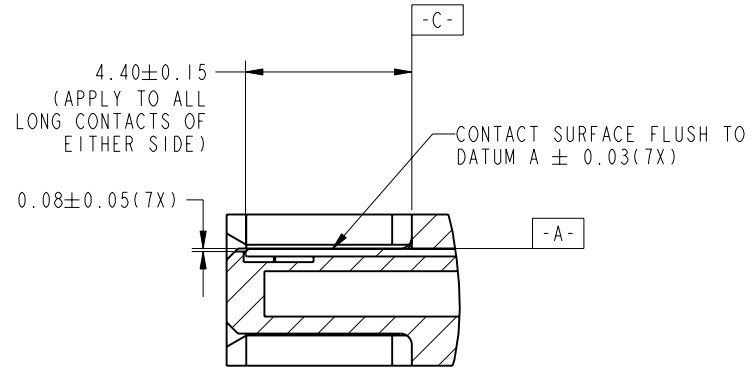
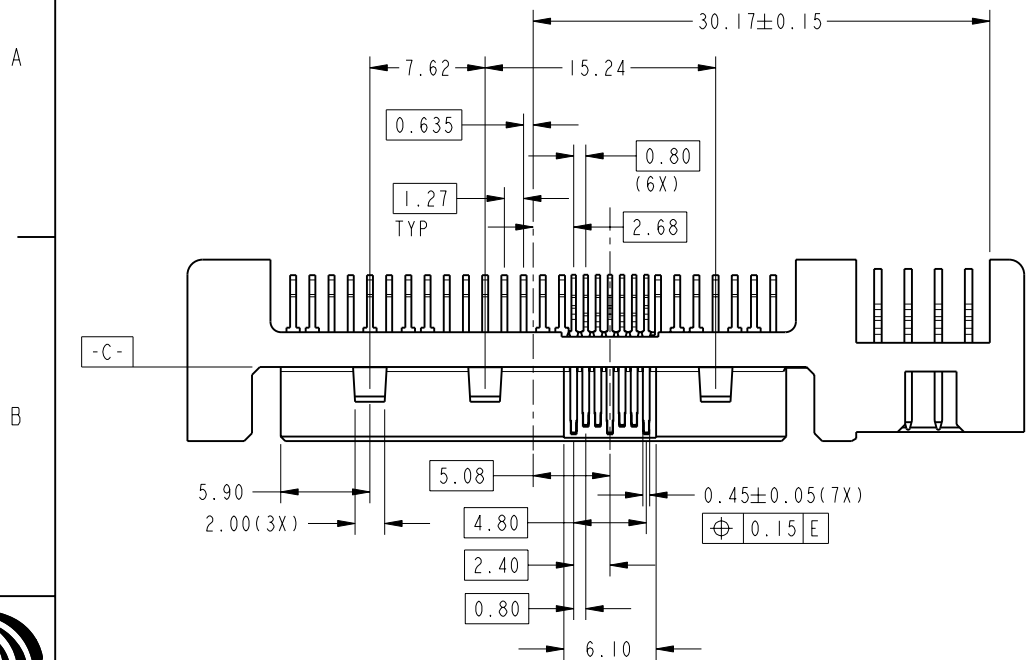

DETAIL 2
SCALE 5:1

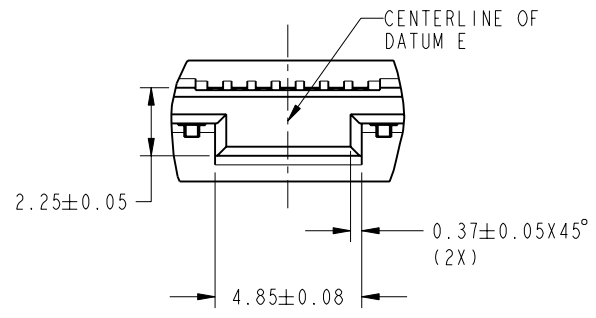

DETAIL 3
SCALE 4:1

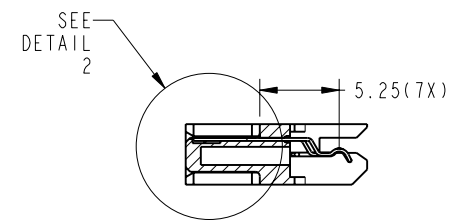
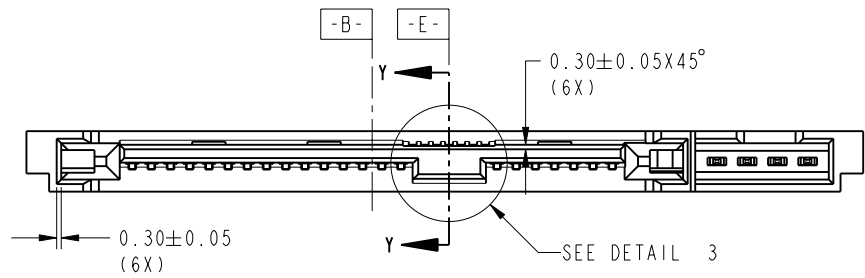

SECTION Y-Y

	title SAS PLUG CONNECTOR	dwg no 10023060	Rev. E
	catalog no	CUSTOMER	sheet 2 of 4



Copyright FCI.

PRODUCT NO.
SEE TABLE

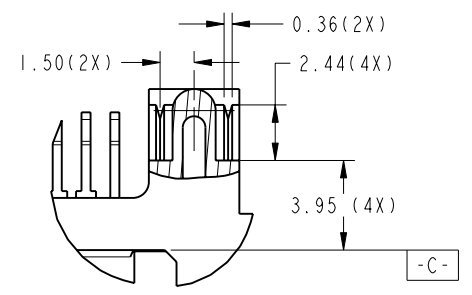
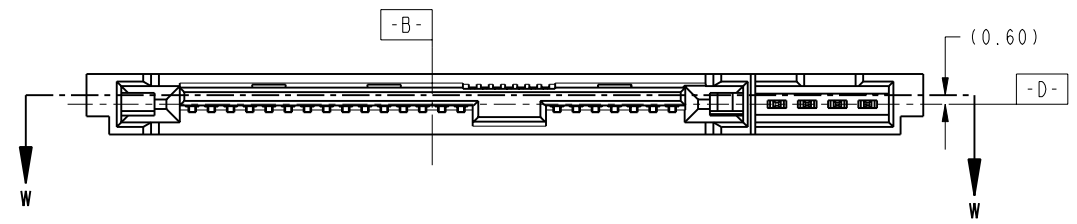
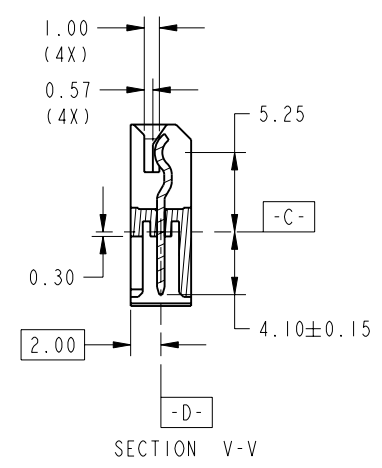
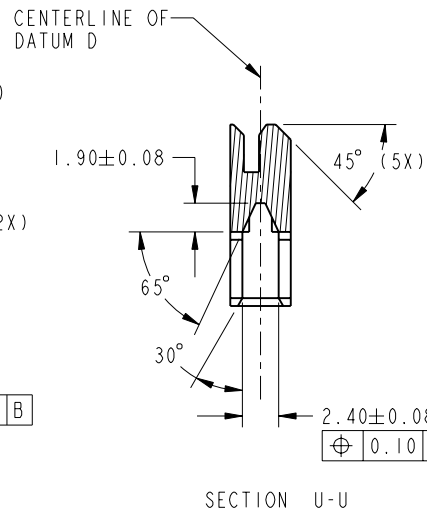
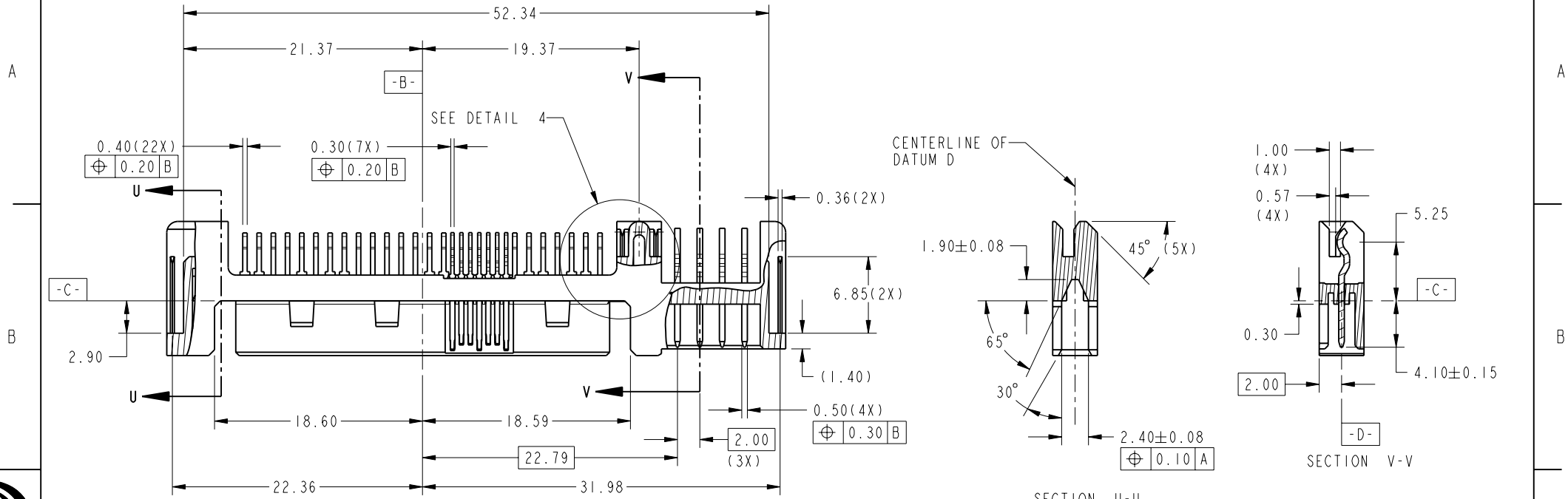

DETAIL 4
SCALE 3:1

FCI
Copyright FCI.

	title SAS PLUG CONNECTOR	dwg no 10023060	Rev. E
	catalog no	CUSTOMER	sheet 3 of 4

REV E - 2004-03-28

PRODUCT NO.
10023060-001LF

A

B

C

D

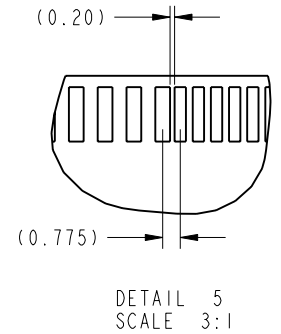
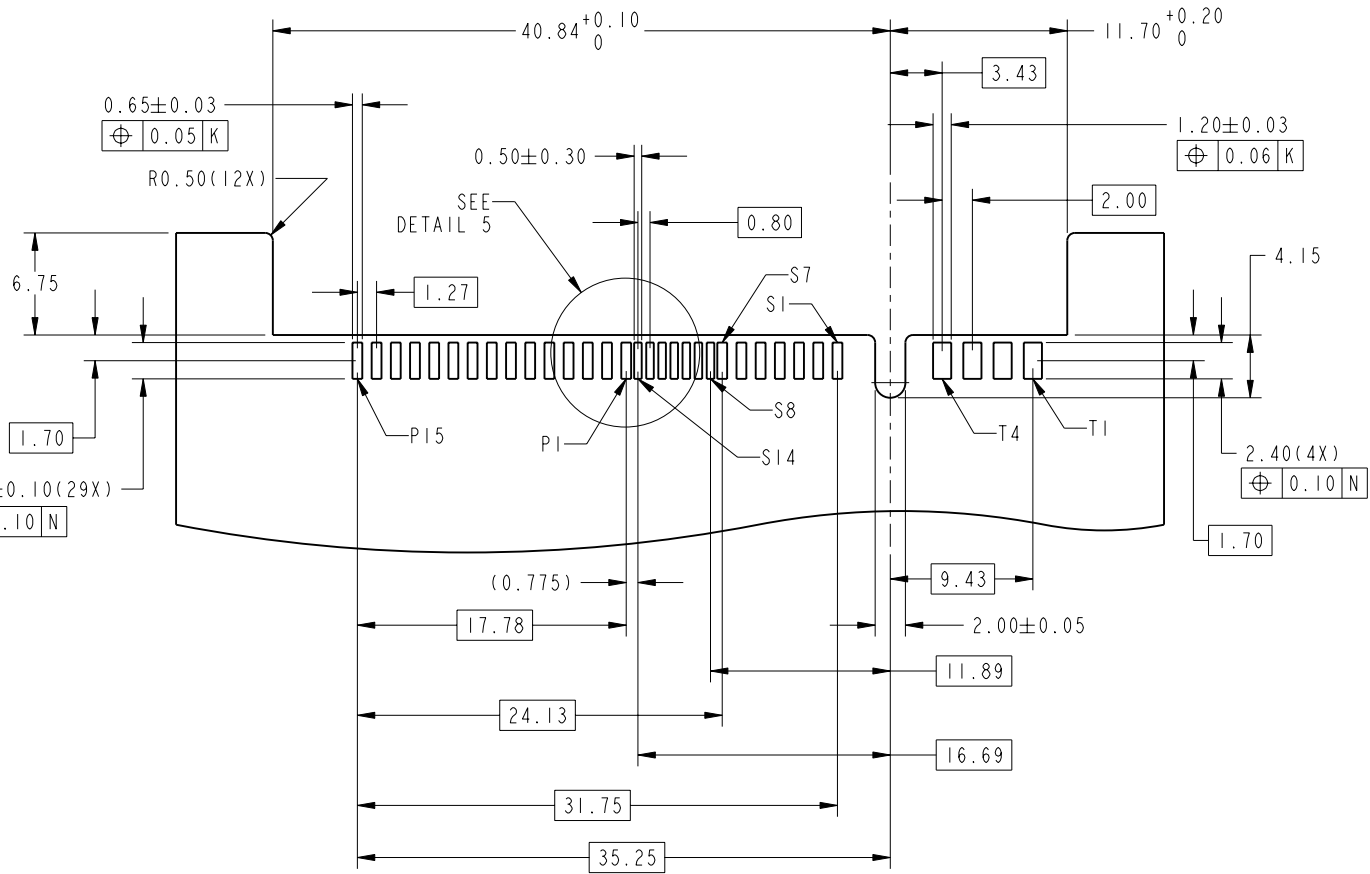

RECOMMENDED SOLDER PAD LAYOUT
SCALE 2:1

NOTES:

1. MATERIAL:
HOUSING: HIGH TEMPERATURE PLASTIC, BLACK OR GRAY
CONTACT & JUMPER PIN: COPPER ALLOY
2. FINISH:
ALL CONTACTS NICKEL UNDERPLATE OVERALL,
TIN (LEAD-FREE) ON SOLDER TAIL,
GOLD IN CONTACT AREA
3. RETENTION FORCE (TERMINAL TO HOUSING): 0.5KG MIN
4. PCB THICKNESS: 0.80mm
5. THE PART SHALL HAVE "FCI" AND DATE CODE
TRACEABLE TO THE YEAR AND WEEK OF MANUFACTURE
SHOWN IN THE APPROXIMATE LOCATION
6. THE PART SHALL HAVE AN OFFSET RECOGNITION MARK OF "+0.5"
SHOWN IN THE APPROXIMATE LOCATION
7. THIS PRODUCT MEETS EUROPEAN UNION DIRECTIVES AND OTHER
COUNTRY REGULATIONS AS DESCRIBED IN GS-22-008
8. THE HOUSING WILL WITHSTAND EXPOSURE TO 260°C PEAK
TEMPERATURE FOR 10 SECONDS IN A CONVECTION, INFRA-RED
OR VAPOR PHASE REFLOW OVEN



Copyright FCI.

	TITLE SAS PLUG CONNECTOR		dwg no 10023060	Rev. E
	catalog no		CUSTOMER	sheet 4 of 4

REV E - 2006-03-28