

THIS DRAWING IS UNPUBLISHED. RELEASED FOR PUBLICATION
 © COPYRIGHT BY TYCO ELECTRONICS CORPORATION. ALL RIGHTS RESERVED.

LOC	DIST	REVISIONS					
G	14	P	LTR	DESCRIPTION	DATE	DWN	APVD
		N		REVISED PER ECR 10-004994	15JUN10	JR	TM

AMP WIRE RANGE	Listed FILE E13288	LR7189 Certified
2 AWG SOLID OR STRANDED	2 AWG STRANDED	2 AWG SOLID OR STRANDED

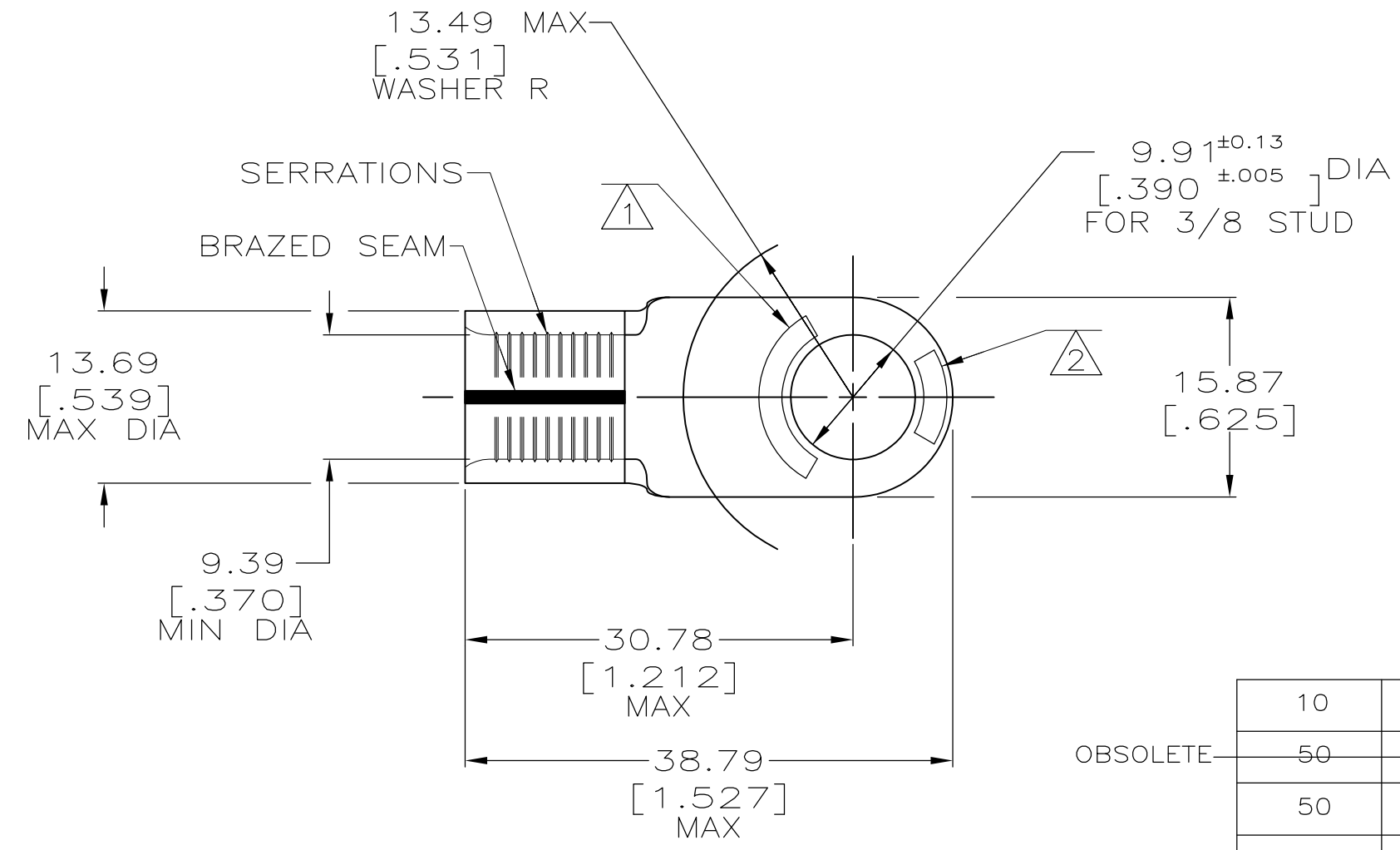

- 1 STAMP AMP 2W* APPROX AS SHOWN
- 2 STAMP 60-75 APPROX AS SHOWN
- 3 MATERIAL THK: 1.78 ± 0.08 [.070 ± 0.003]
- 4 TIN PLATE 0.00254 [.000100] MIN THK PER ASTM B-545
- 5 GOLD PLATE 0.00127 [.000050] MIN THK PER ASTM B-488, TYPE 2, GRADE C, OVER NICKEL PL. 0.00076 [.000030] MIN THK PER QQ-N-290
- 6 MEETS MS20659-114, CLASS 2
- 7 SUPERSEDED BY P/N 321600

10	LOOSE PIECE, BAG	--	4	8-321600-5
50	LOOSE PIECE, BOX	--	4	8-321600-2
50	LOOSE PIECE	--	5	2-321600-1
50	LOOSE PIECE	6	4	321600
QTY	PACKAGE TYPE	MILITARY	FINISH	PART NO

CUSTOMER SERVICE SYSTEMS		MAX RECOMMENDED OPERATING TEMPERATURE: 170° C	THIS DRAWING IS A CONTROLLED DOCUMENT.		DWN DK SCHRUM 5/25/93	Tyco Electronics Corporation Harrisburg, PA 17105-3608	
FOR ADDITIONAL PRODUCT INFORMATION OR COPIES OF DRAWINGS AND TECHNICAL DOCUMENTS	PRODUCT INFORMATION CENTER 1-800-522-6752	VOLTAGE RATING: N/A	DIMENSIONS: INCHES	TOLERANCES UNLESS OTHERWISE SPECIFIED:	CHK RD HEIM 1/27/94	NAME TERMINAL, RING TONGUE, SOLISTRAND	
FOR APPLICATION TOOLING INFORMATION	TOOLING ASSISTANCE CENTER 1-800-722-1111	CIRCULAR MIL AREA: 26.7-42.4mm² [52,600-83,700] SOLID OR STRANDED		0 PLC ± - 1 PLC ± - 2 PLC ± 0.20[.008] 3 PLC ± - 4 PLC ± - ANGLES ± -	APVD J MECKLEY 1/27/94	APPLICATION SPEC	SIZE CAGE CODE DRAWING NO RESTRICTED TO
FOR ORDER ENTRY	1-800-526-5142	THIS DRAWING IS A CONTROLLED DOCUMENT FOR AMP INCORPORATED. IT IS SUBJECT TO CHANGE AND THE CONTROLLING ENGINEERING ORGANIZATION SHOULD BE CONTACTED FOR THE LATEST REVISION.	MATERIAL COPPER ASTM B-152	FINISH SEE TABLE	PRODUCT SPEC	WEIGHT	A3 00779 C-321600
					CUSTOMER DRAWING		SCALE 2:1 SHEET 1 OF 1 REV N