

THIS DRAWING IS UNPUBLISHED. RELEASED FOR PUBLICATION  
 © COPYRIGHT BY TYCO ELECTRONICS CORPORATION. ALL RIGHTS RESERVED.

LOC	DIST	REVISIONS					
G	14	P	LTR	DESCRIPTION	DATE	DWN	APVD
			N1	REV PER ECR 09-026074	30NOV09	JR	TM

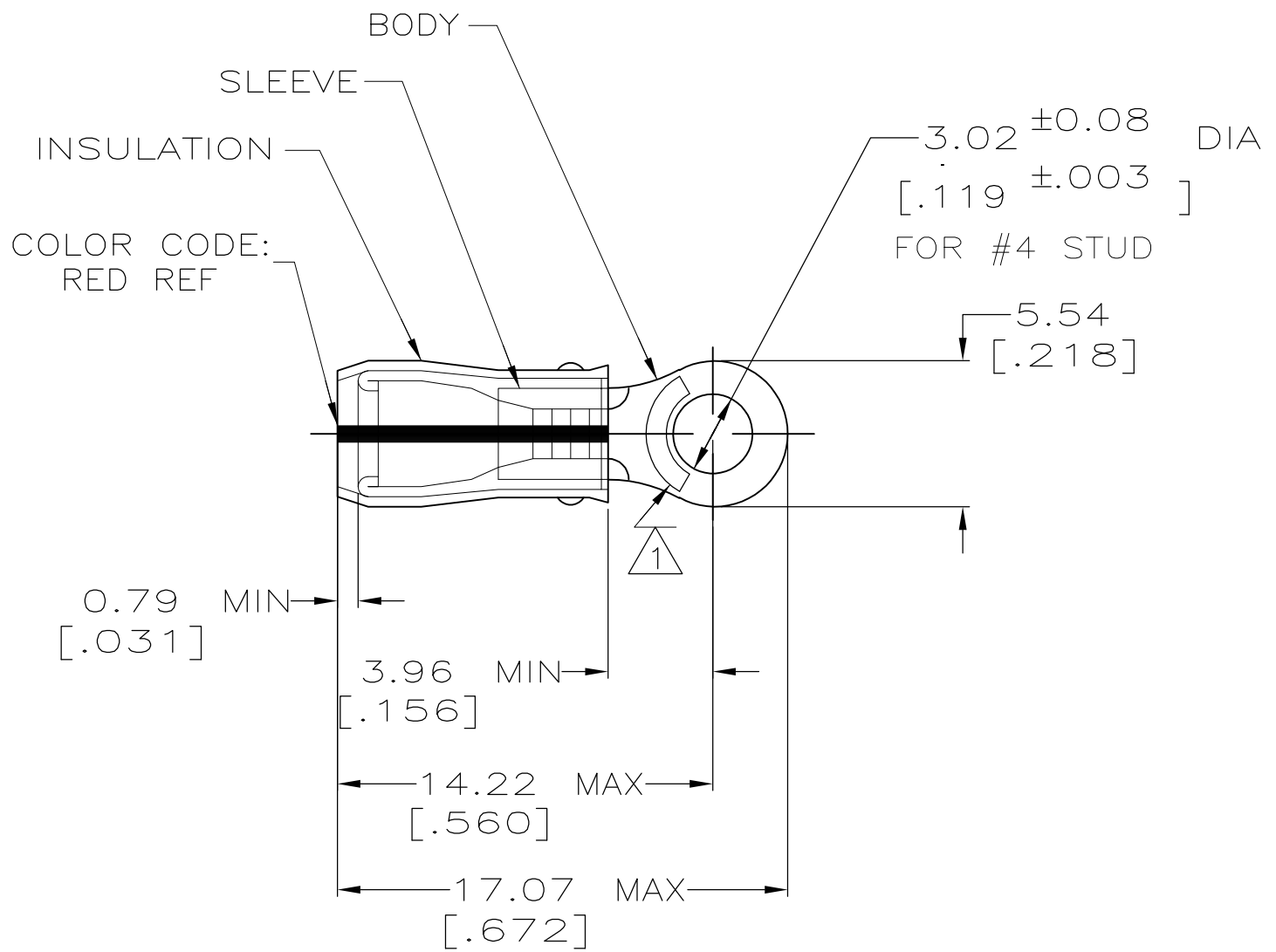

- 1 STAMP AMP 22-18\* APPROX AS SHOWN  
22-16 TERMINALS ARE STAMPED 22-18 IN  
ACCORDANCE WITH MILITARY SPEC MIL-T-7928  
COMMERCIAL WIRE RANGE IS 22-16
- 2 WIRE INSULATION DIA: .080 - .125
- 3 TONGUE MATERIAL THK: 0.79 ±0.05 [.031 ±0.002]
- 4 TIN/LEAD (93-7) PLATE PER ASTM B545.  
( 3% MIN LEAD CONTENT)
- 5 GOLD PL PER ASTM B488, TYPE 2, GRADE C,  
OVER NICKEL PER (QQ-N-290).
- 6 SUPERSEDED BY 53405-1
- 7 MATERIAL: BODY & SLEEVE- CU PER ASTM B152  
INSULATION - PVF2, COLOR - NATURAL

-	4	100	LOOSE PIECE, BOX	8-53405-1
-	-	-	LOOSE PIECE	53405-5 6
-	5	-	LOOSE PIECE	53405-3
M7928/4-148, CLASS 1 & 2 M7928/13-148, CLASS 2	4	-	LOOSE PIECE	53405-1
MILITARY P/N & CLASS	FINISH	QTY	PACKAGE TYPE	PART NO.

AMP INCORPORATED CUSTOMER SERVICE SYSTEMS		MAX RECOMMENDED OPERATING TEMPERATURE: 150°C MAX
FOR ADDITIONAL PRODUCT INFORMATION OR COPIES OF DRAWINGS AND TECHNICAL DOCUMENTS	PRODUCT INFORMATION CENTER 1-800-522-6752	VOLTAGE RATING: N/A
FOR APPLICATION TOOLING INFORMATION	TOOLING ASSISTANCE CENTER 1-800-722-1111	CIRCULAR MIL AREA: 0.26-1.65mm² [509-3260] STRANDED
FOR ORDER ENTRY	1-800-526-5142	THIS DRAWING IS A CONTROLLED DOCUMENT FOR AMP INCORPORATED. IT IS SUBJECT TO CHANGE AND THE CONTROLLING ENGINEERING ORGANIZATION SHOULD BE CONTACTED FOR THE LATEST REVISION.

THIS DRAWING IS A CONTROLLED DOCUMENT.	
DIMENSIONS: MM [INCHES]	TOLERANCES UNLESS OTHERWISE SPECIFIED:
	0 PLC ± - 1 PLC ± - 2 PLC ± 0.20[.008] 3 PLC ± - 4 PLC ± - ANGLES ± -
MATERIAL	FINISH
	BODY: SEE TABLE SLEEVE: SEE NOTE 4

DWN DK SCHRUM 06/16/93	Tyco Electronics Corporation Harrisburg, Pa 17105-3608	
CHK RE HERSEY 7/6/93	NAME TERMINAL, RING TONGUE, PVF2, P.I.D.G. WIRE SIZE: 22-16 AWG	
APVD M BARNABA 7/6/93	PRODUCT SPEC 108-11023	RESTRICTED TO
APPLICATION SPEC NOT AVAILABLE	SIZE A3	CAGE CODE 00779
WEIGHT -	DRAWING NO G-53405	SCALE 4:1
CUSTOMER DRAWING		SHEET 1 OF 1
		REV N1