

THIS DRAWING IS UNPUBLISHED. RELEASED FOR PUBLICATION
 © COPYRIGHT BY TYCO ELECTRONICS CORPORATION. ALL RIGHTS RESERVED.

LOC	DIST	REVISIONS					
		P	LTR	DESCRIPTION	DATE	DWN	APVD
G	14		Z1	REV PER ECR 07-029880	11DEC07	JR	TM

AMP WIRE RANGE	Listed FILE E13288	LR7189 Certified
22-16 AWG SOLID OR STRANDED	22-16 AWG SOLID OR STRANDED	22-16 AWG SOLID OR STRANDED

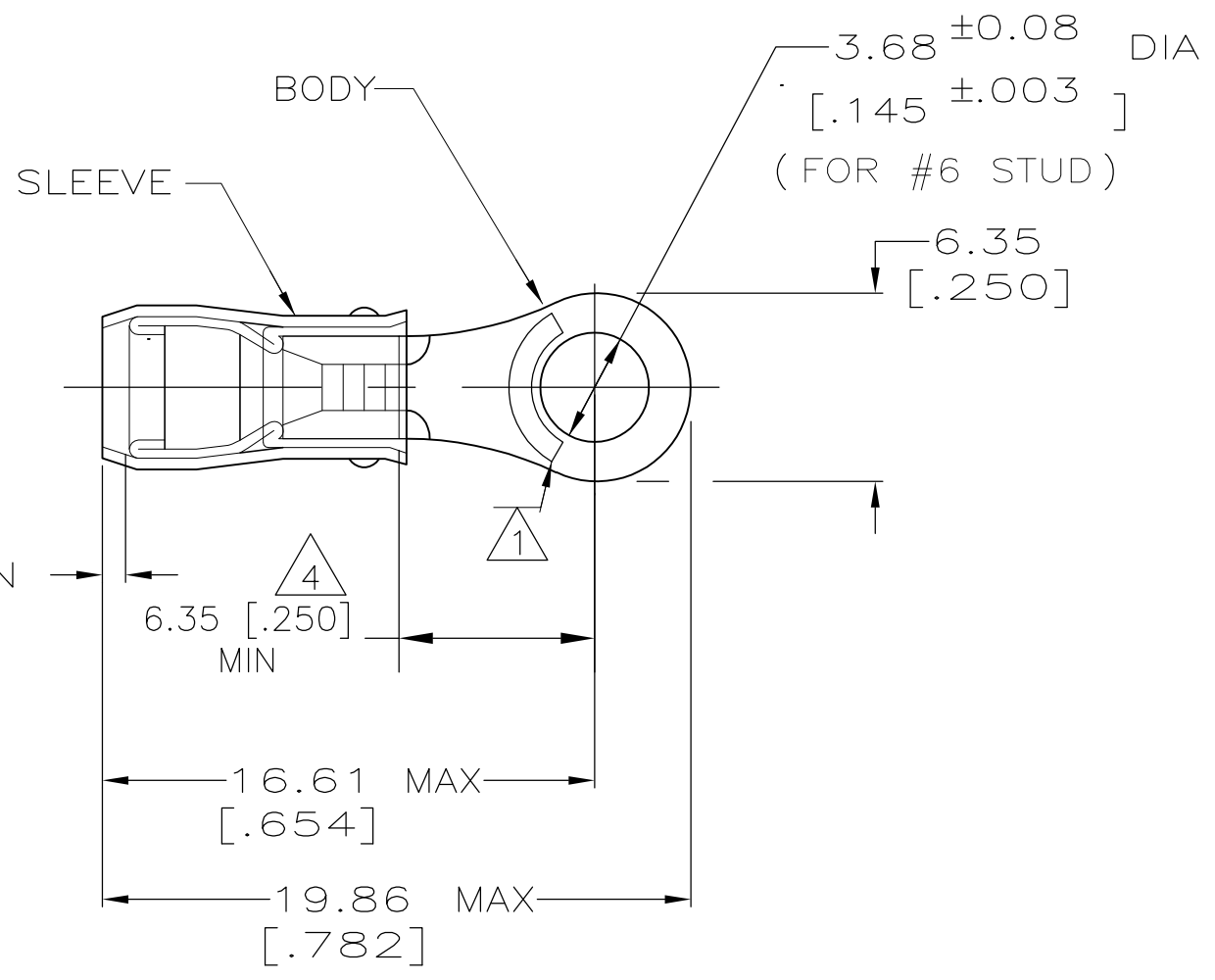

- 1 STAMP AMP 22-18* APPROX AS SHOWN
22-16 TERMINALS ARE STAMPED 22-18 IN ACCORDANCE WITH MILITARY SPEC MIL-T-7928
COMMERCIAL WIRE RANGE IS 22-16
- 2 WIRE INSULATION DIA: 2.03 - 3.18
[.080 - .125]
- 3 TONGUE MATERIAL THK: 0.79±0.05
[.031±.002]
- 4 DIMENSION APPLIES FROM EDGE OF METAL WIRE BARREL TO CENTER OF STUD HOLE.
- 5 BODY - COPPER PER ASTM B-152
SLEEVE - NYLON
- 6 BODY - TIN PLATE PER ASTM B545
SLEEVE - COLOR - RED

MILITARY P/N AND CLASS	QTY	PACKAGE TYPE	PART NUMBER
--	100	LOOSE PIECE, BOX	7-51863-1
MS25036-102 CLASS 2	5000	ON TAPE, REEL	51863-1
MS25036-102 CLASS 1 & 2	1000	LOOSE PIECE	51863

AMP INCORPORATED CUSTOMER SERVICE SYSTEMS		MAX RECOMMENDED OPERATING TEMPERATURE: 105°C MAX	THIS DRAWING IS A CONTROLLED DOCUMENT.		DWN DK SCHRUM 9/8/93	Tyco Electronics Corporation Harrisburg, PA 17105-3608			
FOR ADDITIONAL PRODUCT INFORMATION OR COPIES OF DRAWINGS AND TECHNICAL DOCUMENTS	PRODUCT INFORMATION CENTER 1-800-522-6752	VOLTAGE RATING: 300V MAX	DIMENSIONS: MM [INCHES]	TOLERANCES UNLESS OTHERWISE SPECIFIED:	CHKY RE HERSEY 9/8/93	NAME M BARNABA			
FOR APPLICATION TOOLING INFORMATION	TOOLING ASSISTANCE CENTER 1-800-722-1111	CIRCULAR MIL AREA: 0.26-1.65mm² [509-3260] CIR MILS SOLID OR STRANDED		0 PLC ± - 1 PLC ± - 2 PLC ± 0.20 [.008] 3 PLC ± - 4 PLC ± - ANGLES ± -	APVD M BARNABA 9/8/93	PRODUCT SPEC UL 486A			
FOR ORDER ENTRY	1-800-526-5142	THIS DRAWING IS A CONTROLLED DOCUMENT FOR AMP INCORPORATED. IT IS SUBJECT TO CHANGE AND THE CONTROLLING ENGINEERING ORGANIZATION SHOULD BE CONTACTED FOR THE LATEST REVISION.	MATERIAL - 5	FINISH - 6	APPLICATION SPEC NOT AVAILABLE	SIZE A3	CAGE CODE 00779	DRAWING NO C-51863	RESTRICTED TO -
CUSTOMER DRAWING					SCALE NTS	SHEET 1 OF 2	REV Z1		

THIS DRAWING IS UNPUBLISHED. RELEASED FOR PUBLICATION
 © COPYRIGHT BY TYCO ELECTRONICS CORPORATION. ALL RIGHTS RESERVED.

LOC	DIST	REVISIONS					
G	14	P	LTR	DESCRIPTION	DATE	DWN	APVD
		-		SEE SHEET 1	-	-	-

AMP
WIRE RANGE

SEE TABLE
STRANDED

1 STAMP AMP APPROX AS SHOWN
SEE TABLE BELOW

2 WIRE INSULATION DIA:

0.97 - 2.79 FOR 22 AWG
[.038 - .110]
1.17 - 2.79 FOR 20 AWG
[.046 - .110]
1.42 - 2.79 FOR 18 AWG
[.056 - .110]

3 TONGUE MATERIAL THK: 0.79±0.05
[.031±.002]

4 DIMENSION APPLIES FROM EDGE OF METAL
WIRE BARREL TO CENTER OF STUD HOLE.

5 BODY - COPPER PER ASTM B-152
SLEEVE - NYLON

6 BODY - TIN PLATE PER ASTM B545
SLEEVE - COLOR - RED

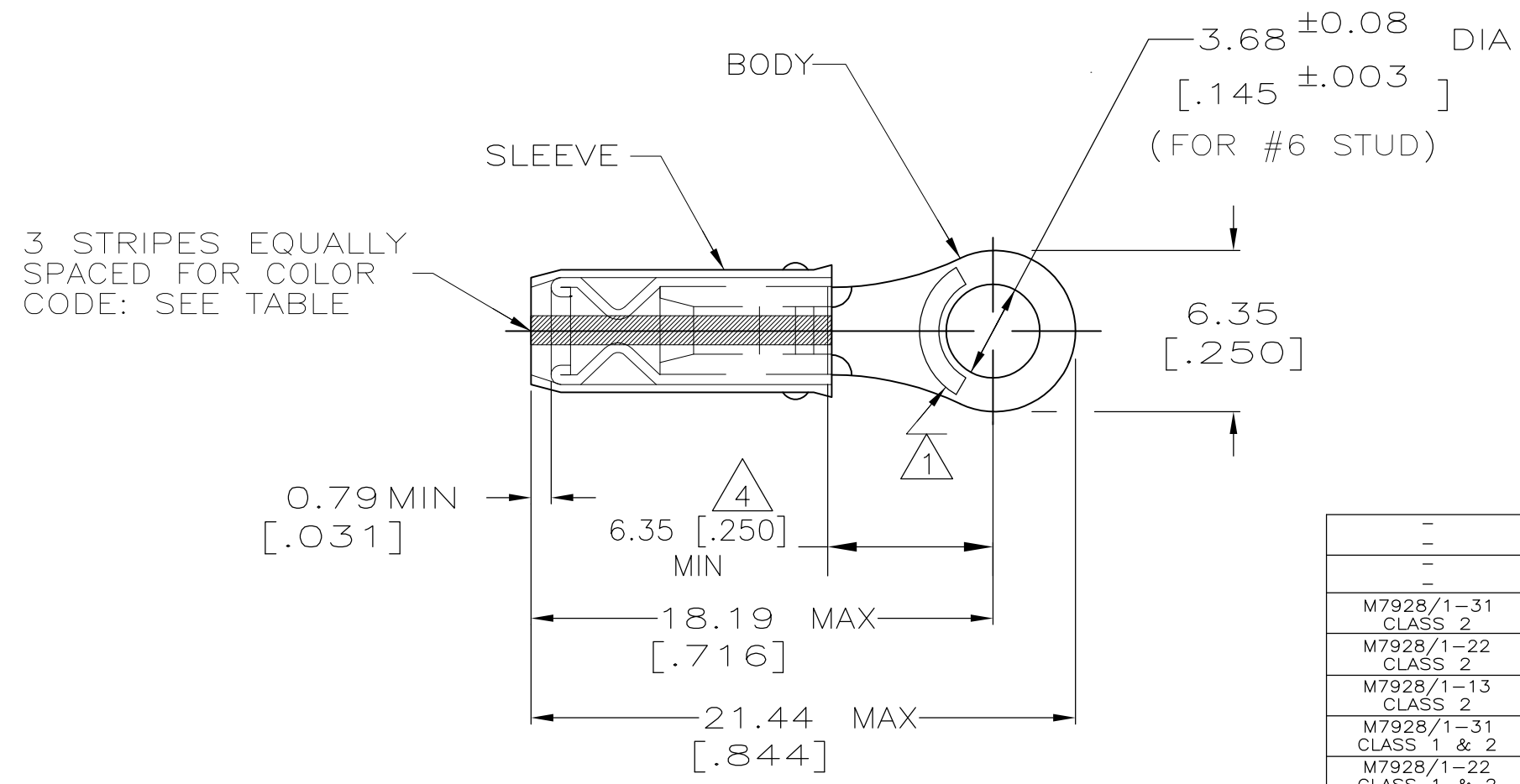

-	WHITE	18*	18	100	LOOSE PIECE, BOX	9-51863-1
-	GREEN	22*	22	100	LOOSE PIECE, BOX	8-51863-1
M7928/1-31 CLASS 2	WHITE	18*	18	5000	ON TAPE, REEL	51863-7
M7928/1-22 CLASS 2	RED	20*	20	5000	ON TAPE, REEL	51863-6
M7928/1-13 CLASS 2	GREEN	22*	22	5000	ON TAPE, REEL	51863-5
M7928/1-31 CLASS 1 & 2	WHITE	18*	18	1000	LOOSE PIECE	51863-4
M7928/1-22 CLASS 1 & 2	RED	20*	20	1000	LOOSE PIECE	51863-3
M7928/1-13 CLASS 1 & 2	GREEN	22*	22	1000	LOOSE PIECE	51863-2
MILITARY P/N AND CLASS	STRIPE COLOR	1 STAMPING	WIRE SIZE	QTY	PACKAGE TYPE	PART NO.

AMP INCORPORATED CUSTOMER SERVICE SYSTEMS		MAX RECOMMENDED OPERATING TEMPERATURE: 105°C	THIS DRAWING IS A CONTROLLED DOCUMENT.		DWN DK SCHRUM 9/8/93	Tyco Electronics Corporation Harrisburg, PA 17105-3608					
FOR ADDITIONAL PRODUCT INFORMATION OR COPIES OF DRAWINGS AND TECHNICAL DOCUMENTS	PRODUCT INFORMATION CENTER 1-800-522-6752	VOLTAGE RATING: 300V MAX	DIMENSIONS: MM [INCHES]	TOLERANCES UNLESS OTHERWISE SPECIFIED:	CHK RE HERSEY 9/8/93	NAME M BARNABA 9/8/93					
FOR APPLICATION TOOLING INFORMATION	TOOLING ASSISTANCE CENTER 1-800-722-1111	WIRE RANGE CIR MIL AREA: 22 0.38mm² [754] 20 0.60mm² [1,186] 18 0.96mm² [1,900] STRANDED		0 PLC ± - 1 PLC ± - 2 PLC ± 0.20[.008] 3 PLC ± - 4 PLC ± - ANGLES ± -	APVD M BARNABA 9/8/93	TERMINAL, RING TONGUE, I.R., PIDG, WIRE SIZE 22-16 AWG					
FOR ORDER ENTRY	1-800-526-5142	THIS DRAWING IS A CONTROLLED DOCUMENT FOR AMP INCORPORATED. IT IS SUBJECT TO CHANGE AND THE CONTROLLING ENGINEERING ORGANIZATION SHOULD BE CONTACTED FOR THE LATEST REVISION.	MATERIAL - 5	FINISH - 6	PRODUCT SPEC -	APPLICATION SPEC NOT AVAILABLE	RESTRICTED TO -				
			CUSTOMER DRAWING		WEIGHT -	SIZE A3	CAGE CODE 00779	DRAWING NO G-51863	SCALE NTS	SHEET 2 OF 2	REV Z1