

RF power transistor, LdmoST family

Features

- Excellent thermal stability
- Common source configuration
- $P_{OUT} = 15\text{ W}$ with 11 dB gain @ 2 GHz / 13.6 V
- Plastic package
- ESD protection
- In compliance with the 2002/95/EC european directive

Description

The PD20015-E is a common source N-channel, enhancement-mode lateral field-effect RF power transistor. It is designed for high gain, broadband commercial and industrial applications. It operates at 13.6 V in common source mode at frequencies of up to 1 GHz. PD20015-E boasts the excellent gain, linearity and reliability of ST's latest LDMOS technology mounted in the first true SMD plastic RF power package, PowerSO-10RF. PD20015-E's superior linearity performance makes it an ideal solution for mobile radio applications.

The PowerSO-10 plastic package, designed to offer high reliability, is the first ST JEDEC approved, high power SMD package. It has been specially optimized for RF needs and offers excellent RF performances and ease of assembly. Mounting recommendations are available in www.st.com/ (look for application note AN1294)

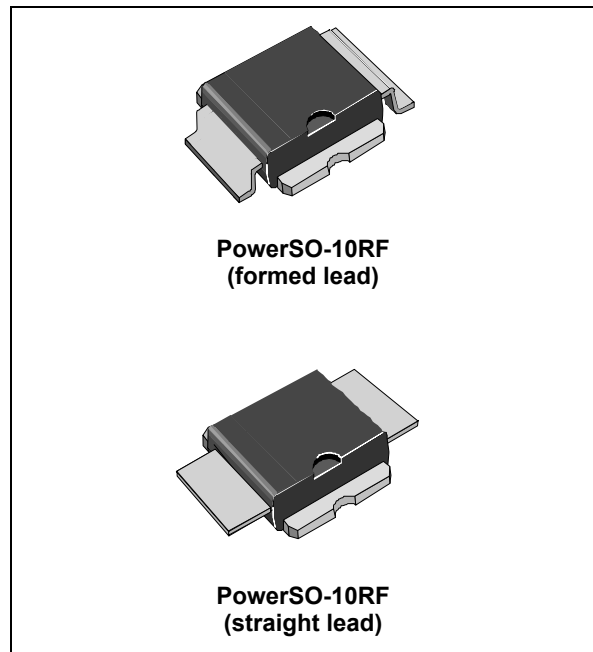

Figure 1. Pin connection

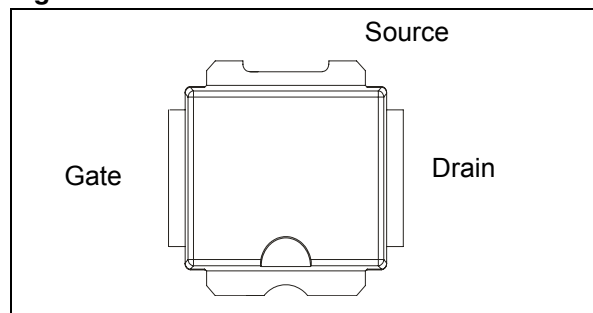

Table 1. Device summary

| Order codes | Package | Packing |
|--------------|------------------------------|---------------|
| PD20015-E | PowerSO-10RF (formed lead) | Tube |
| PD20015S-E | PowerSO-10RF (straight lead) | |
| PD20015TR-E | PowerSO-10RF (formed lead) | Tape and reel |
| PD20015STR-E | PowerSO-10RF (straight lead) | |

Contents

| | | |
|----------|---|-----------|
| 1 | Electrical data | 3 |
| 1.1 | Maximum ratings | 3 |
| 1.2 | Thermal data | 3 |
| 2 | Electrical characteristics | 4 |
| 2.1 | Static | 4 |
| 2.2 | Dynamic | 4 |
| 2.3 | ESD protection characteristics | 5 |
| 2.4 | Moisture sensitivity level | 5 |
| 3 | Impedance | 6 |
| 4 | Typical performance | 7 |
| 5 | Package mechanical data | 10 |
| 6 | Revision history | 15 |

1 Electrical data

1.1 Maximum ratings

$T_{CASE} = 25\text{ °C}$

Table 2. Absolute maximum ratings

| Symbol | Parameter | Value | Unit |
|---------------|---|-------------|------|
| $V_{(BR)DSS}$ | Drain-source voltage | 40 | V |
| V_{GS} | Gate-source voltage | -0.5 to +15 | V |
| I_D | Drain current | 7 | A |
| P_{DISS} | Power dissipation (@ $T_C = 70\text{ °C}$) | 79 | W |
| T_J | Max. operating junction temperature | 165 | °C |
| T_{STG} | Storage temperature | -65 to +150 | °C |

1.2 Thermal data

Table 3. Thermal data

| Symbol | Parameter | Value | Unit |
|------------|------------------------------------|-------|------|
| R_{thJC} | Junction - case thermal resistance | 1.2 | °C/W |

2 Electrical characteristics

$T_{CASE} = +25\text{ }^{\circ}\text{C}$

2.1 Static

Table 4. Static

| Symbol | Test conditions | | | Min. | Typ. | Max. | Unit |
|--------------|------------------------|--------------------------|--------------------|------|------|------|---------------|
| I_{DSS} | $V_{GS} = 0\text{ V}$ | $V_{DS} = 25\text{ V}$ | | - | | 1 | μA |
| I_{GSS} | $V_{GS} = 5\text{ V}$ | $V_{DS} = 0\text{ V}$ | | - | | 1 | μA |
| $V_{GS(Q)}$ | $V_{DS} = 10\text{ V}$ | $I_D = 350\text{ mA}$ | | - | 4.2 | | V |
| $V_{DS(ON)}$ | $V_{GS} = 10\text{ V}$ | $I_D = 1\text{ A}$ | | - | 0.27 | 0.31 | V |
| C_{ISS} | $V_{GS} = 0\text{ V}$ | $V_{DS} = 12.5\text{ V}$ | $f = 1\text{ MHz}$ | - | 55 | | pF |
| C_{OSS} | $V_{GS} = 0\text{ V}$ | $V_{DS} = 12.5\text{ V}$ | $f = 1\text{ MHz}$ | - | 40 | | pF |
| C_{RSS} | $V_{GS} = 0\text{ V}$ | $V_{DS} = 12.5\text{ V}$ | $f = 1\text{ MHz}$ | - | 1.5 | | pF |

2.2 Dynamic

Table 5. Dynamic

| Symbol | Test conditions | | | Min. | Typ. | Max. | Unit |
|---------------|---|--|--------------------|------|------|------|------|
| P3dB | $V_{DD} = 13.6\text{ V}$, $I_{DQ} = 350\text{ mA}$ | | $f = 2\text{ GHz}$ | | 23 | - | W |
| G_P | $V_{DD} = 13.6\text{ V}$, $I_{DQ} = 350\text{ mA}$, $P_{OUT} = 15\text{ W}$, $f = 2\text{ GHz}$ | | | 10 | 11 | - | dB |
| h_D | $V_{DD} = 13.6\text{ V}$, $I_{DQ} = 350\text{ mA}$, $P_{OUT} = P_{3dB}$, $f = 2\text{ GHz}$ | | | 45 | 53 | - | % |
| Load mismatch | $V_{DD} = 15.5\text{ V}$, $I_{DQ} = 350\text{ mA}$, $P_{OUT} = 20\text{ W}$, $f = 2\text{ GHz}$ all phase angles | | | 20:1 | | - | VSWR |

2.3 ESD protection characteristics

Table 6. ESD protection characteristics

| Test conditions | Class |
|------------------|-------|
| Human body model | 2 |
| Machine model | M3 |

2.4 Moisture sensitivity level

Table 7. Moisture sensitivity level

| Test methodology | Rating |
|------------------|--------|
| J-STD-020B | MSL 3 |

3 Impedance

Figure 2. Current conventions

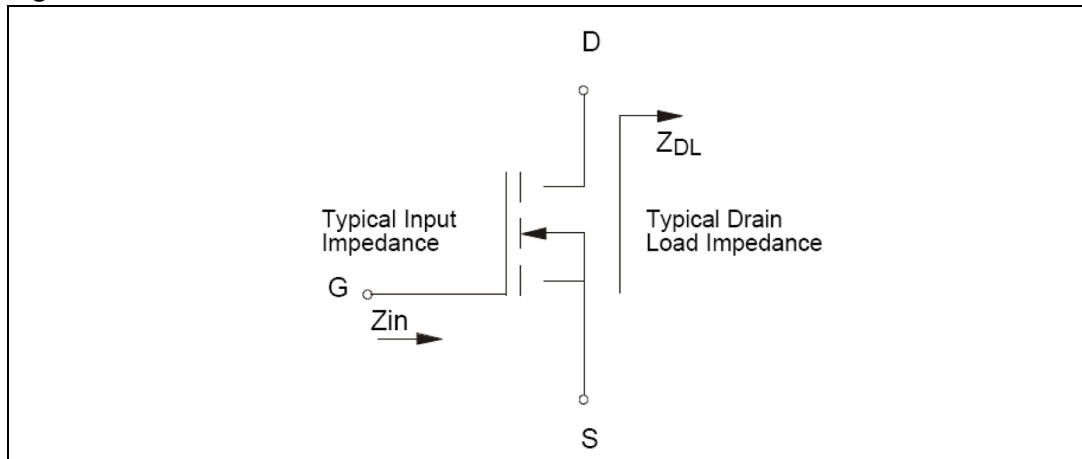

Table 8. Impedance data

| Freq. (MHz) | $Z_{IN} (\Omega)$ | $Z_{DL}(\Omega)$ |
|-------------|-------------------|------------------|
| 2000 | $0.45 + j0.99$ | $0.99-j0.9$ |

4 Typical performance

Figure 3. Capacitances vs drain voltage

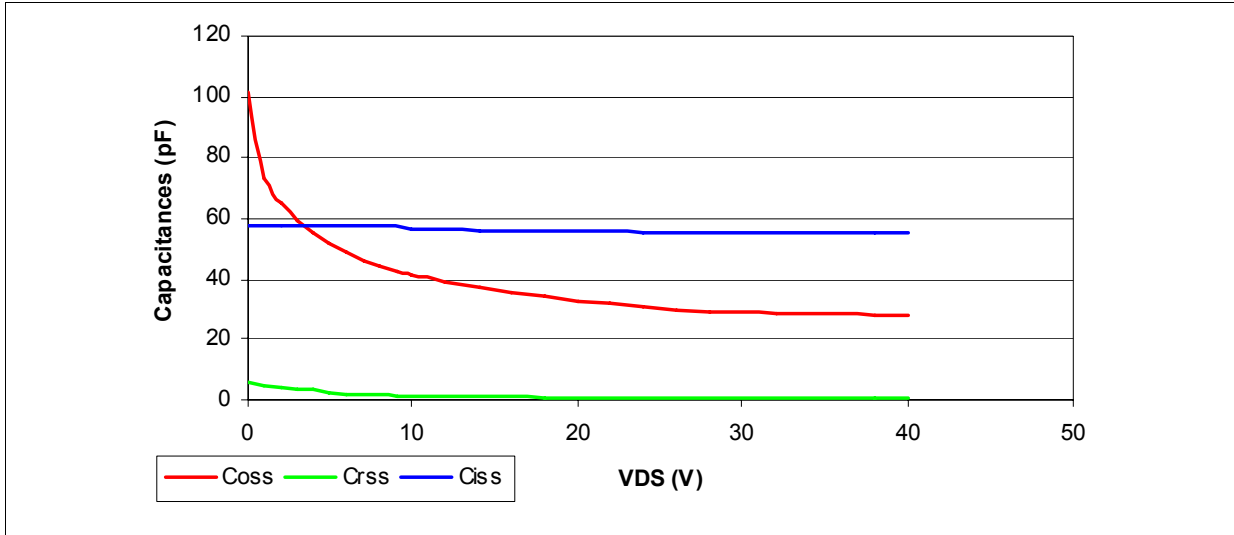

Figure 4. DC output characteristics

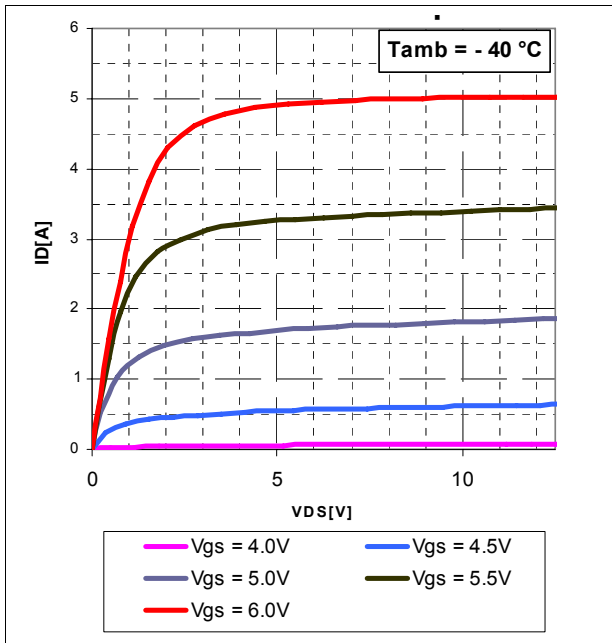

Figure 5. DC output characteristics

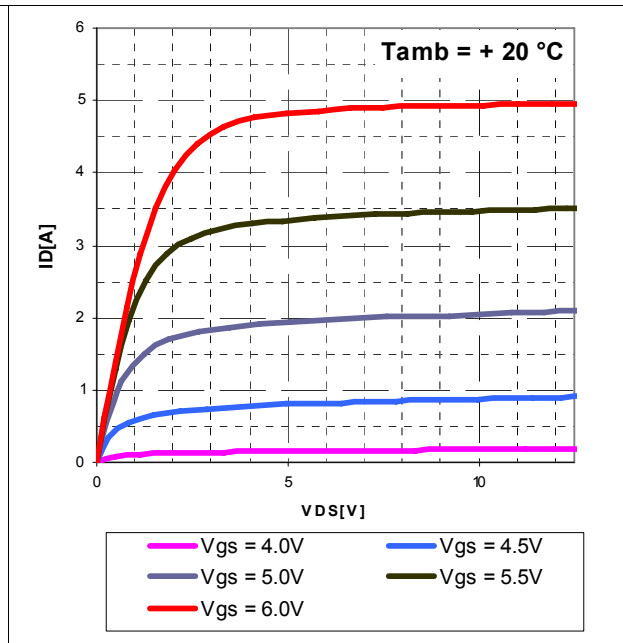

Figure 6. DC output characteristics

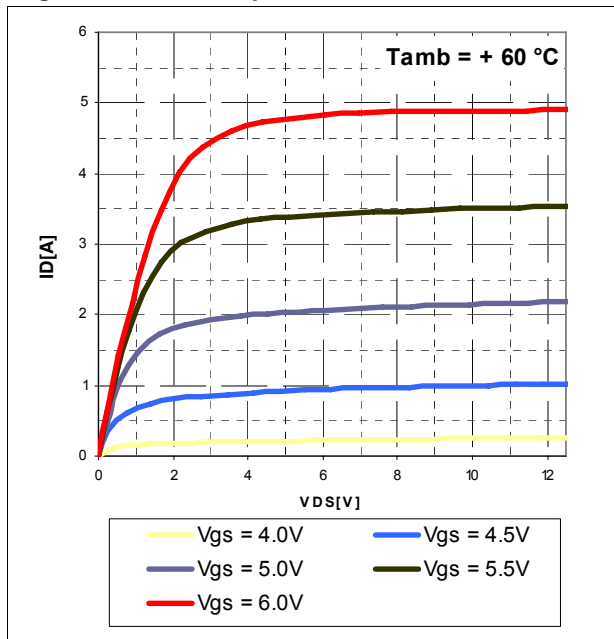

Figure 7. Gain and efficiency vs P_{OUT}

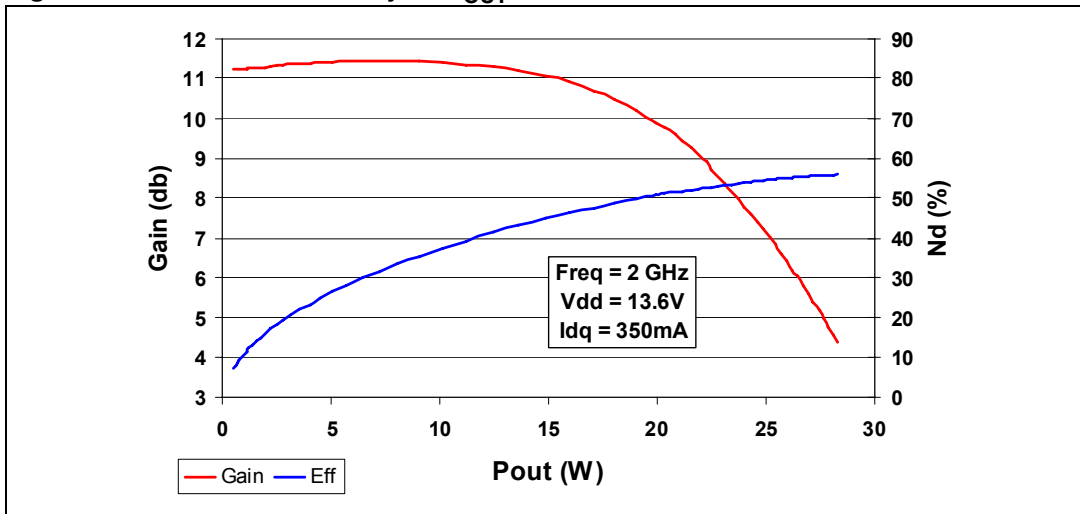
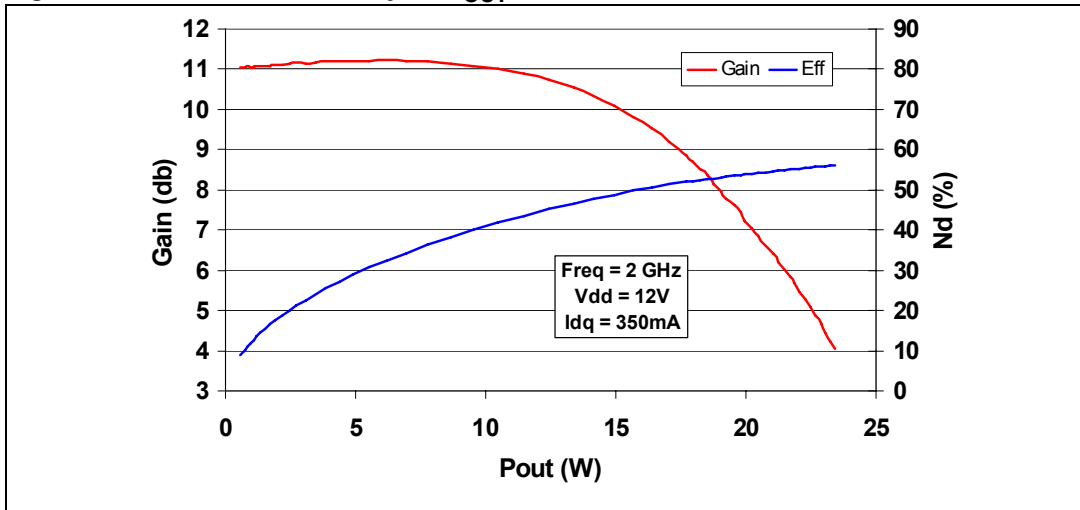

Figure 8. Gain and efficiency vs P_{OUT}



5 Package mechanical data

In order to meet environmental requirements, ST offers these devices in different grades of ECOPACK[®] packages, depending on their level of environmental compliance. ECOPACK[®] specifications, grade definitions and product status are available at: www.st.com. ECOPACK[®] is an ST trademark.

Table 9. PowerSO-10RF formed lead (gull wing) mechanical data

| Dim. | mm. | | | Inch | | |
|------|-------|--------|-------|-------|--------|--------|
| | Min. | Typ. | Max. | Min. | Typ. | Max. |
| A1 | 0 | 0.05 | 0.1 | 0. | 0.0019 | 0.0038 |
| A2 | 3.4 | 3.5 | 3.6 | 0.134 | 0.137 | 0.142 |
| A3 | 1.2 | 1.3 | 1.4 | 0.046 | 0.05 | 0.054 |
| A4 | 0.15 | 0.2 | 0.25 | 0.005 | 0.007 | 0.009 |
| a | | 0.2 | | | 0.007 | |
| b | 5.4 | 5.53 | 5.65 | 0.212 | 0.217 | 0.221 |
| c | 0.23 | 0.27 | 0.32 | 0.008 | 0.01 | 0.012 |
| D | 9.4 | 9.5 | 9.6 | 0.370 | 0.374 | 0.377 |
| D1 | 7.4 | 7.5 | 7.6 | 0.290 | 0.295 | 0.298 |
| E | 13.85 | 14.1 | 14.35 | 0.544 | 0.555 | 0.565 |
| E1 | 9.3 | 9.4 | 9.5 | 0.365 | 0.37 | 0.375 |
| E2 | 7.3 | 7.4 | 7.5 | 0.286 | 0.292 | 0.294 |
| E3 | 5.9 | 6.1 | 6.3 | 0.231 | 0.24 | 0.247 |
| F | | 0.5 | | | 0.019 | |
| G | | 1.2 | | | 0.047 | |
| L | 0.8 | 1 | 1.1 | 0.030 | 0.039 | 0.042 |
| R1 | | | 0.25 | | | 0.01 |
| R2 | | 0.8 | | | 0.031 | |
| T | 2 deg | 5 deg | 8 deg | 2 deg | 5 deg | 8 deg |
| T1 | | 6 deg | | | 6 deg | |
| T2 | | 10 deg | | | 10 deg | |

Note: Resin protrusions not included (Max. value: 0.15 mm per side)

Figure 9. Package dimensions

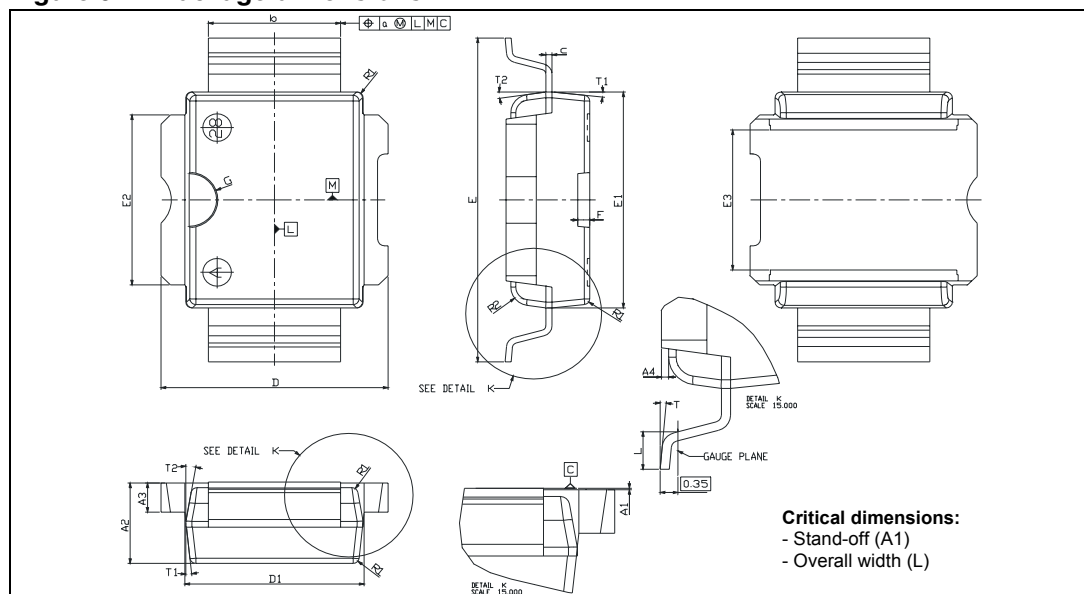

Table 10. PowerSO-10RF straight lead mechanical data

| Dim. | mm. | | | Inch | | |
|------|-------|--------|-------|-------|--------|-------|
| | Min. | Typ. | Max. | Min. | Typ. | Max. |
| A1 | 1.62 | 1.67 | 1.72 | 0.064 | 0.065 | 0.068 |
| A2 | 3.4 | 3.5 | 3.6 | 0.134 | 0.137 | 0.142 |
| A3 | 1.2 | 1.3 | 1.4 | 0.046 | 0.05 | 0.054 |
| A4 | 0.15 | 0.2 | 0.25 | 0.005 | 0.007 | 0.009 |
| a | | 0.2 | | | 0.007 | |
| b | 5.4 | 5.53 | 5.65 | 0.212 | 0.217 | 0.221 |
| c | 0.23 | 0.27 | 0.32 | 0.008 | 0.01 | 0.012 |
| D | 9.4 | 9.5 | 9.6 | 0.370 | 0.374 | 0.377 |
| D1 | 7.4 | 7.5 | 7.6 | 0.290 | 0.295 | 0.298 |
| E | 15.15 | 15.4 | 15.65 | 0.595 | 0.606 | 0.615 |
| E1 | 9.3 | 9.4 | 9.5 | 0.365 | 0.37 | 0.375 |
| E2 | 7.3 | 7.4 | 7.5 | 0.286 | 0.292 | 0.294 |
| E3 | 5.9 | 6.1 | 6.3 | 0.231 | 0.24 | 0.247 |
| F | | 0.5 | | | 0.019 | |
| G | | 1.2 | | | 0.047 | |
| R1 | | | 0.25 | | | 0.01 |
| R2 | | 0.8 | | | 0.031 | |
| T1 | | 6 deg | | | 6 deg | |
| T2 | | 10 deg | | | 10 deg | |

Note: Resin protrusions not included (Max. value: 0.15 mm per side)

Figure 10. Package dimensions

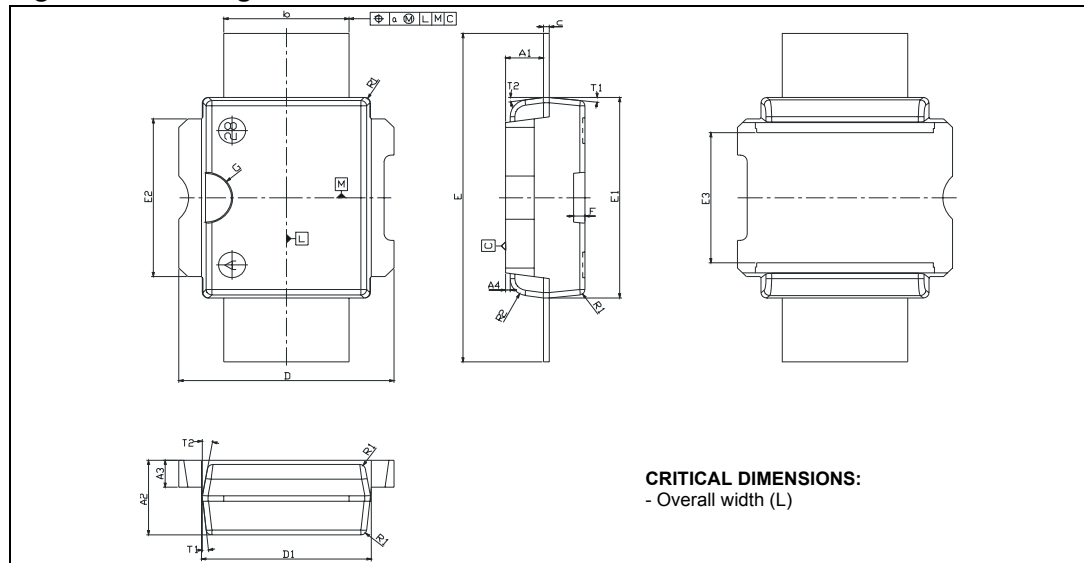

Figure 11. Tube information

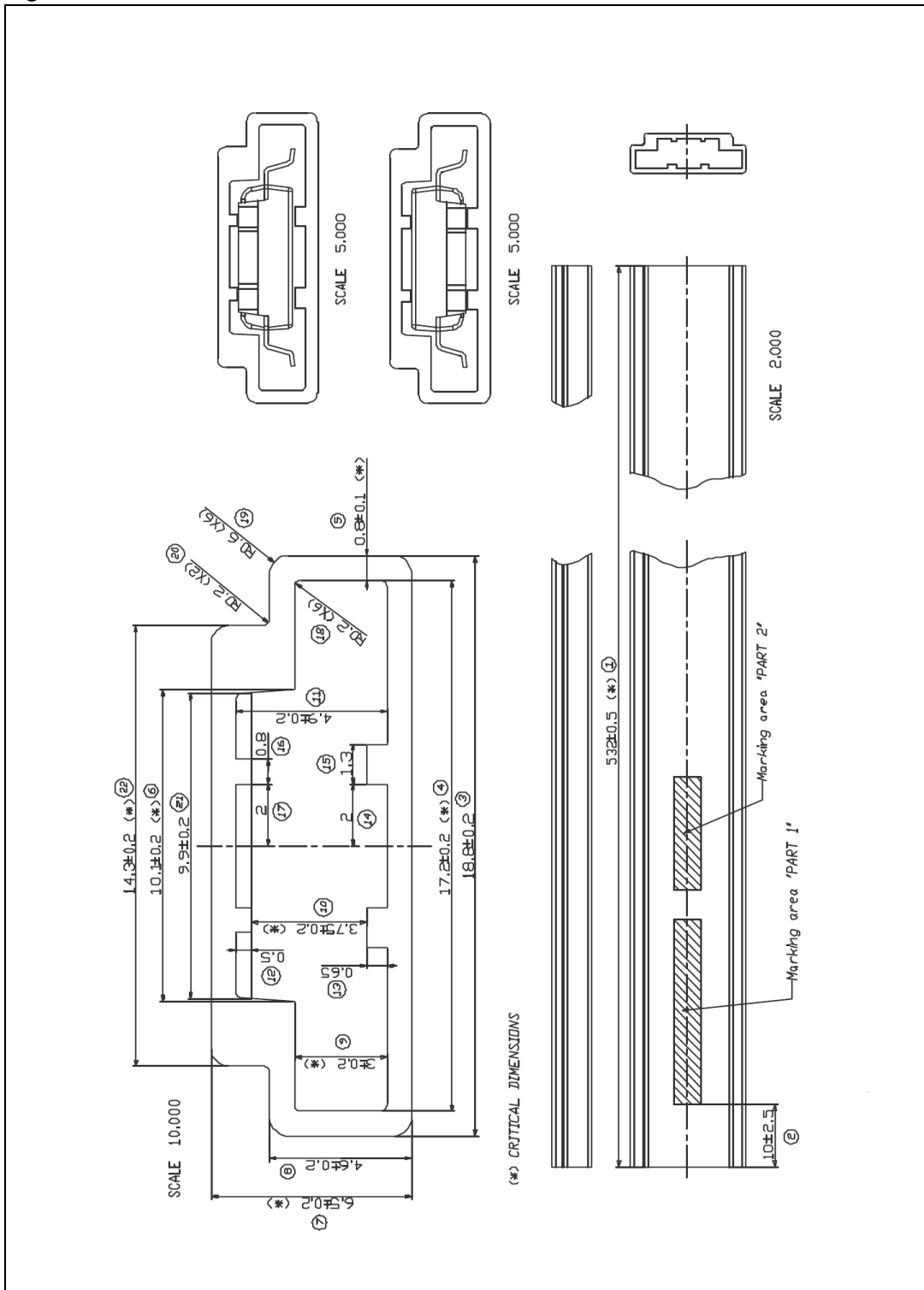
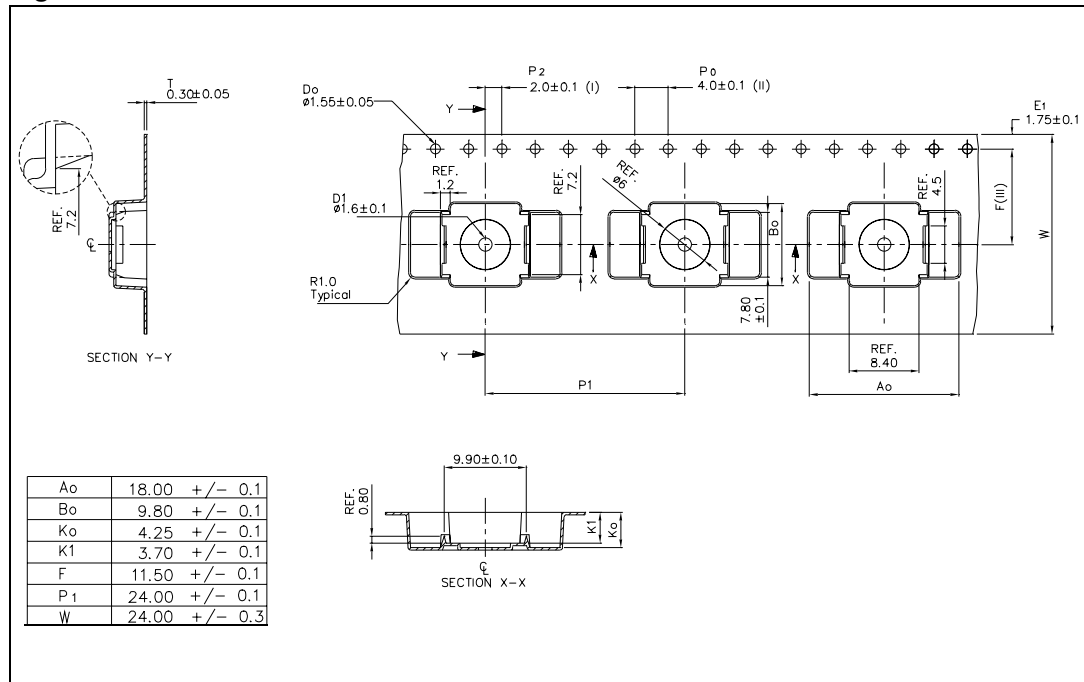

Figure 12. Reel information



6 Revision history

Table 11. Document revision history

| Date | Revision | Changes |
|-------------|----------|---|
| 14-Dec-2007 | 1 | Initial release. |
| 14-Apr-2009 | 2 | Updated Table 4 on page 4 |

Please Read Carefully:

Information in this document is provided solely in connection with ST products. STMicroelectronics NV and its subsidiaries ("ST") reserve the right to make changes, corrections, modifications or improvements, to this document, and the products and services described herein at any time, without notice.

All ST products are sold pursuant to ST's terms and conditions of sale.

Purchasers are solely responsible for the choice, selection and use of the ST products and services described herein, and ST assumes no liability whatsoever relating to the choice, selection or use of the ST products and services described herein.

No license, express or implied, by estoppel or otherwise, to any intellectual property rights is granted under this document. If any part of this document refers to any third party products or services it shall not be deemed a license grant by ST for the use of such third party products or services, or any intellectual property contained therein or considered as a warranty covering the use in any manner whatsoever of such third party products or services or any intellectual property contained therein.

UNLESS OTHERWISE SET FORTH IN ST'S TERMS AND CONDITIONS OF SALE ST DISCLAIMS ANY EXPRESS OR IMPLIED WARRANTY WITH RESPECT TO THE USE AND/OR SALE OF ST PRODUCTS INCLUDING WITHOUT LIMITATION IMPLIED WARRANTIES OF MERCHANTABILITY, FITNESS FOR A PARTICULAR PURPOSE (AND THEIR EQUIVALENTS UNDER THE LAWS OF ANY JURISDICTION), OR INFRINGEMENT OF ANY PATENT, COPYRIGHT OR OTHER INTELLECTUAL PROPERTY RIGHT.

UNLESS EXPRESSLY APPROVED IN WRITING BY AN AUTHORIZED ST REPRESENTATIVE, ST PRODUCTS ARE NOT RECOMMENDED, AUTHORIZED OR WARRANTED FOR USE IN MILITARY, AIR CRAFT, SPACE, LIFE SAVING, OR LIFE SUSTAINING APPLICATIONS, NOR IN PRODUCTS OR SYSTEMS WHERE FAILURE OR MALFUNCTION MAY RESULT IN PERSONAL INJURY, DEATH, OR SEVERE PROPERTY OR ENVIRONMENTAL DAMAGE. ST PRODUCTS WHICH ARE NOT SPECIFIED AS "AUTOMOTIVE GRADE" MAY ONLY BE USED IN AUTOMOTIVE APPLICATIONS AT USER'S OWN RISK.

Resale of ST products with provisions different from the statements and/or technical features set forth in this document shall immediately void any warranty granted by ST for the ST product or service described herein and shall not create or extend in any manner whatsoever, any liability of ST.

ST and the ST logo are trademarks or registered trademarks of ST in various countries.

Information in this document supersedes and replaces all information previously supplied.

The ST logo is a registered trademark of STMicroelectronics. All other names are the property of their respective owners.

© 2009 STMicroelectronics - All rights reserved

STMicroelectronics group of companies

Australia - Belgium - Brazil - Canada - China - Czech Republic - Finland - France - Germany - Hong Kong - India - Israel - Italy - Japan - Malaysia - Malta - Morocco - Philippines - Singapore - Spain - Sweden - Switzerland - United Kingdom - United States of America

www.st.com