

THIS DRAWING IS UNPUBLISHED. RELEASED FOR PUBLICATION
 © COPYRIGHT BY TYCO ELECTRONICS CORPORATION. ALL RIGHTS RESERVED.

LOC	DIST	REVISIONS					
DF	DO	P	LTR	DESCRIPTION	DATE	DWN	APVD
		P		UPDATE PER 0H2Y-0164-04	05-12-04	JDM	MKS

D

C

B

A

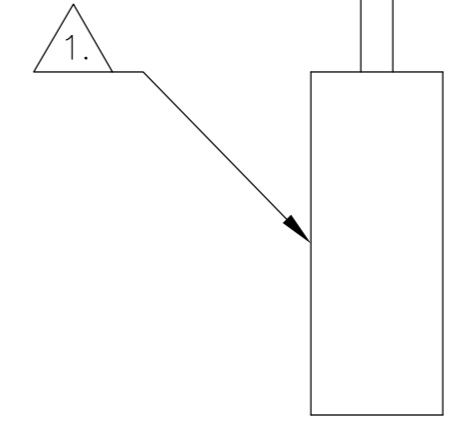
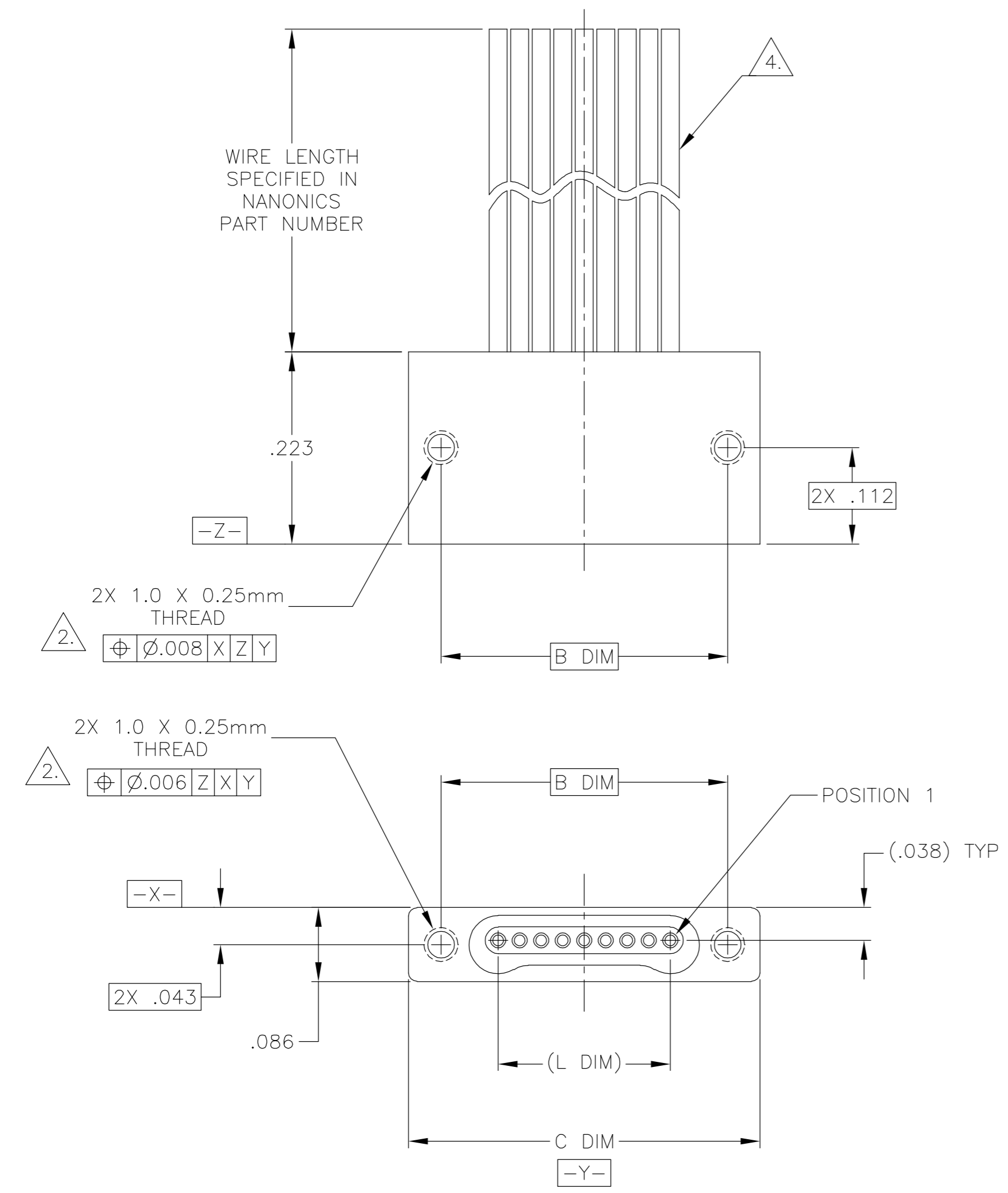

D

C

B

A

SIZE	B DIM	C DIM ±.0050	(L DIM)
05	.233	.3085	(.100)
09	.333	.4085	(.200)
15	.483	.5585	(.350)
25	.733	.8085	(.600)
37	1.033	1.1085	(.900)
51	1.383	1.4585	(1.250)

- 1. SHELL OPTIONS (TO BE SPECIFIED IN NANONICS PART NUMBER):
 METAL: 6061-T6 ALUMINUM, ELECTROLESS NICKEL PLATED PER MIL-C-26074 (STANDARD) OR GOLD PLATED PER MIL-G-45204
 303 STAINLESS STEEL, PASSIVATED PER SAE-AMS-QQ-P-35
 INSULATOR MATERIAL FOR ALL METAL SHELLS IS LIQUID CRYSTAL POLYMER (LCP) PER MIL-M-24519 OR PER ASTM D5138
 PLASTIC: LIQUID CRYSTAL POLYMER (LCP) PER MIL-M-24519 OR PER ASTM D5138
- 2. STANDARD 1.0 X 0.25mm JACKSCREW AND MOUNTING THREADS ARE SHOWN FOR REFERENCE ONLY AND MUST BE SPECIFIED IN THE NANONICS PART NUMBER WHEN REQUIRED. 1.2 X 0.25mm THREADS ALSO AVAILABLE.
- 3. MOUNTING HARDWARE IS AVAILABLE WITH THIS CONFIGURATION (NOT SHOWN). HARDWARE MUST BE SPECIFIED IN THE NANONICS PART NUMBER. CONSULT TYCO ELECTRONICS FOR DETAILS.
- 4. THIS CONFIGURATION MAY BE TERMINATED WITH 28 AWG SOLID, 30 AWG STRANDED OR SMALLER WIRE, OR RIBBON CABLE. CONDUCTOR TYPE AND LENGTH MUST BE SPECIFIED IN NANONICS PART NUMBER.
- 5. THIS DRAWING PREVIOUSLY IDENTIFIED AS NANONICS N10138/102

THIS DRAWING IS A CONTROLLED DOCUMENT.		DWN D. RYAN 20 APR 92	Tyco Electronics Corporation Harrisburg, PA 17105	
DIMENSIONS: INCHES		CHK E. PAULUS 05-15-98		
TOLERANCES UNLESS OTHERWISE SPECIFIED:		APVD M. STORRY 04-05-01	NAME	
0 PLC ± - 1 PLC ± - 2 PLC ± .010 3 PLC ± .005 4 PLC ± - ± 1° ANGLES ± 1°		PRODUCT SPEC	RECEPTACLE ASSEMBLY, FLYING LEADS, SINGLE ROW DUALLOBE, PLASTIC OR METAL	
MATERIAL SEE NOTES		APPLICATION SPEC	SIZE A2	CAGE CODE 00779
FINISH SEE NOTES		WEIGHT -	DRAWING NO C=1589457	RESTRICTED TO -
CUSTOMER DRAWING			SCALE 8:1	SHEET 1 OF 1

1589457