

THIS DRAWING IS UNPUBLISHED. RELEASED FOR PUBLICATION  
 © COPYRIGHT BY TYCO ELECTRONICS CORPORATION. ALL INTERNATIONAL RIGHTS RESERVED.

LOC		DIST		REVISIONS			
P	LTR	DESCRIPTION		DATE	DWN	APVD	
G	14	P2		REVISED PER ECR-09-026553	08DEC09	JR	TM

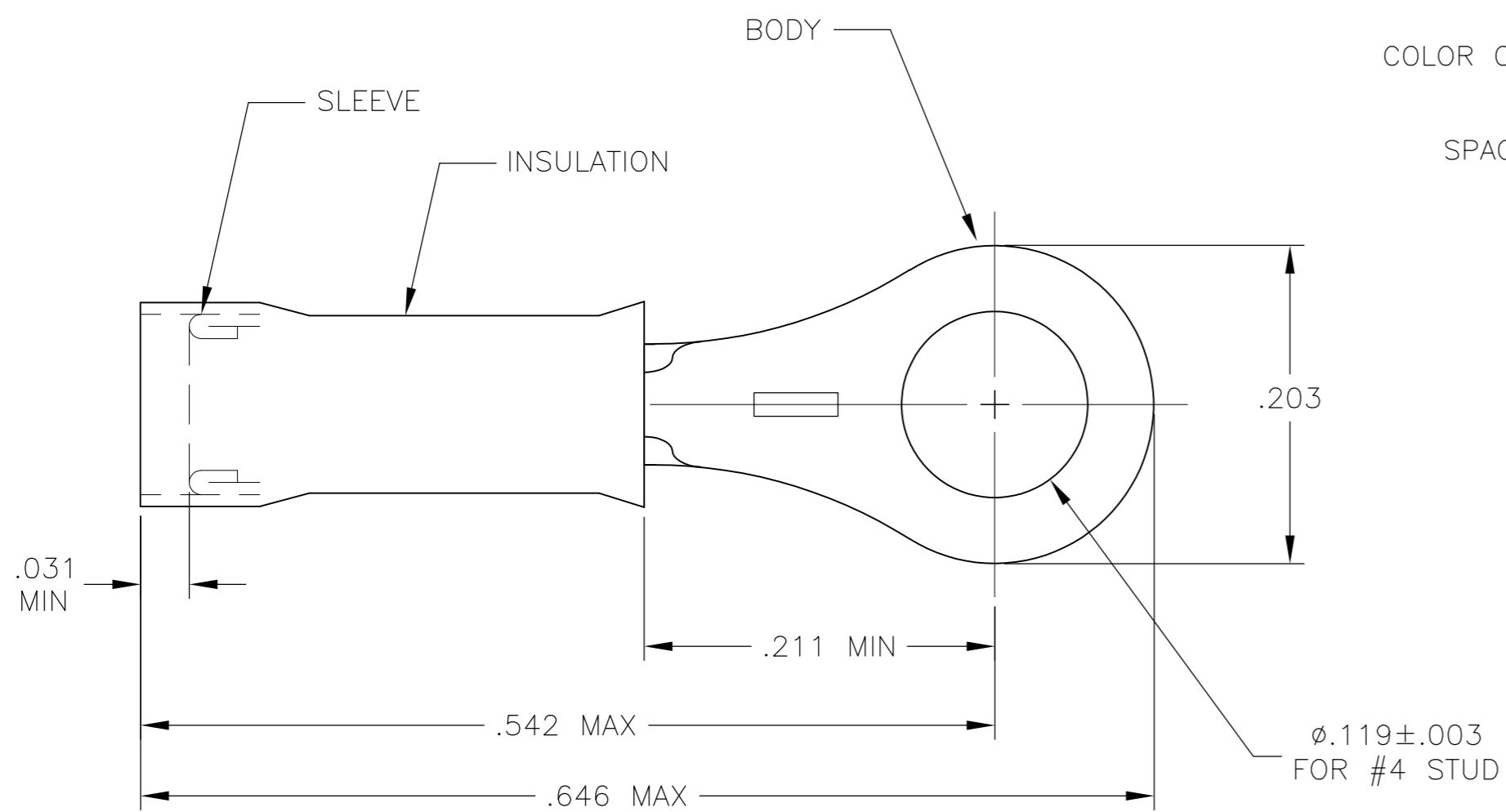

FIGURE 1  
 FOR .050 TO .082 WIRE INSULATION DIA

COLOR CODE STRIPE  
 SEE TABLE  
 3 EQUALLY  
 SPACED STRIPES

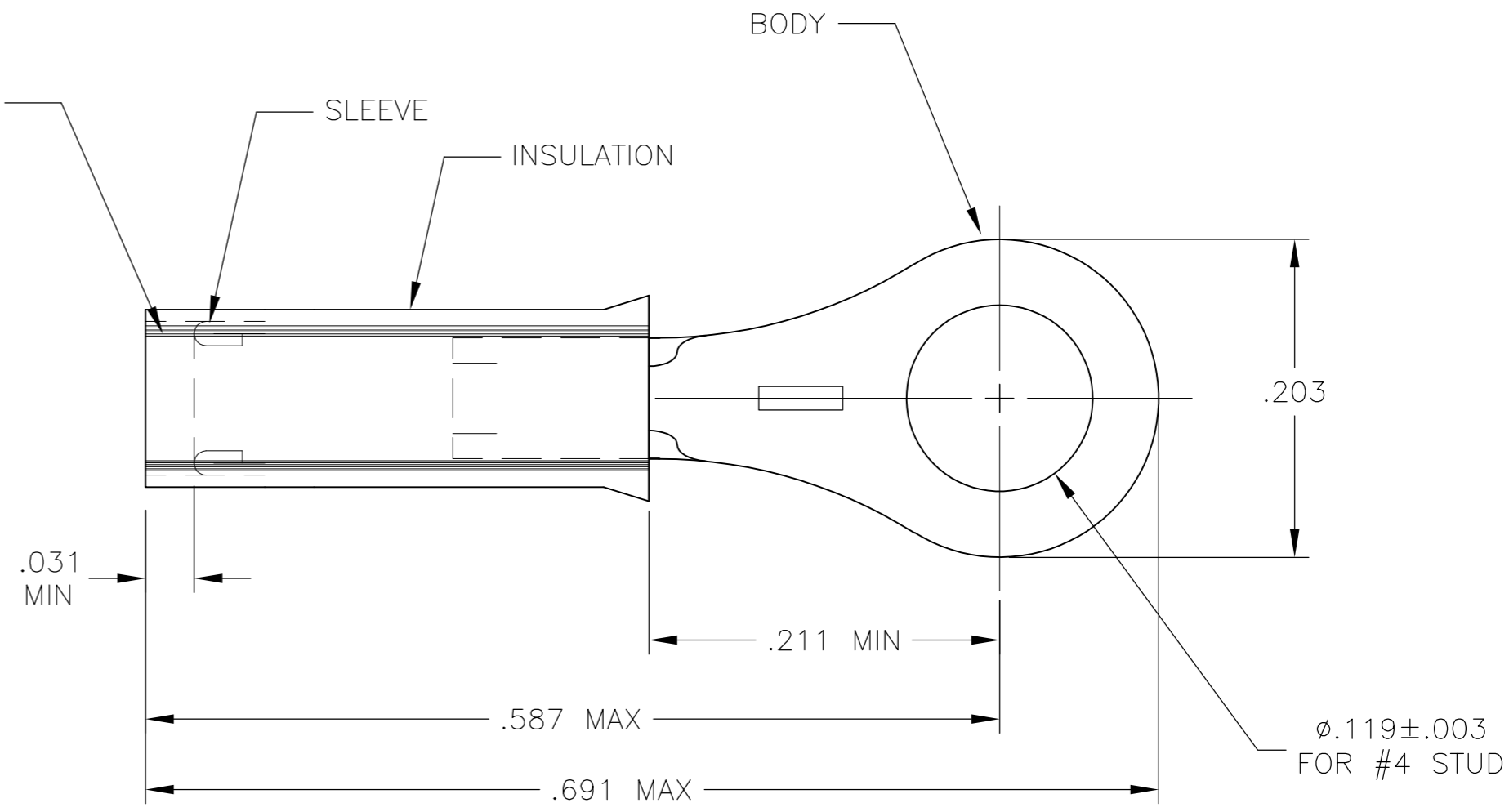

FIGURE 2  
 INSULATION RESTRICTING  
 FOR X/Y WIRE INSULATION DIA

- 1 TONGUE MATERIAL THK IS .018±.002
- 2 MEETS MS25036-144, CLASS 2

1	WIRE TERMINAL INSULATION RESTRICTING	BODY: COPPER (ASTM-B152) TIN PL (ASTM-B545) SLEEVE: COPPER (ASTM-B152) NICKEL PL. (QQ-N-290) INSULATION: NYLON COLOR: YELLOW (ASTM-D4066) TYPE 1	2-323914-2
100	LOOSE PC, BOX		8-323914-1
4000	323914 ON TAPE	BODY & SLEEVE: COPPER (ASTM-B152) TIN PL (ASTM-B545) INSULATION: NYLON COLOR: YELLOW (ASTM-D4066) TYPE 1	2-323914-1
1	WIRE TERMINAL		323914
QTY	DESCRIPTION	MATERIAL & FINISH	PART NO

PART NO.	STYLE	WIRE SIZE	STRIPE COLOR	"X/Y"	PART NO. ON TAPE
8-323914-1	FIGURE 1	#26-#22	NONE	-	
2-323914-2	FIGURE 2	#24	BLACK	.031/.055	
323914	FIGURE 1	#26-#22	NONE	-	2-323914-1

THIS DRAWING IS A CONTROLLED DOCUMENT.

DWN	JR RUTH	02OCT09	Tyco Electronics Corporation Harrisburg, PA 17105-3608			
CHK	TOM MICHIELUTTI	02OCT09				
APVD	MIKE PERCHERKE	02OCT09				
NAME	TERMINAL, NYLON - PIDG - RING TONGUE					
DIMENSIONS: INCHES	TOLERANCES UNLESS OTHERWISE SPECIFIED:	0 PLC ± -	SIZE	CAGE CODE	DRAWING NO	RESTRICTED TO
	1 PLC ± -	2 PLC ± -	A2	00779	C=323914	-
	3 PLC ± .008	4 PLC ± -	WEIGHT	-		SCALE
	ANGLES ± 5°	FINISH	-		10:1	SHEET
	MATERIAL	SEE TABLE	CUSTOMER DRAWING	-		1 of 1
				REV	P2	