

DATA SHEET

# SMP1322 Series: Low Resistance, Plastic Packaged PIN Diodes

## Applications

- High-performance wireless switch applications

## Features

- Resistance: 0.8  $\Omega$  typical @ 1 mA
- Packages rated MSL1, 260 °C per JEDEC J-STD-020)

**NEW**



Skyworks Green™ products are RoHS (Restriction of Hazardous Substances)-compliant, conform to the EIA/EICTA/JEITA Joint Industry Guide (JIG) Level A guidelines, are halogen free according to IEC-61249-2-21, and contain <1,000 ppm antimony trioxide in polymeric materials.



## Description

The SMP1322 series of plastic packaged, surface mountable PIN diodes is designed for use in high volume switch applications from 10 MHz to more than 2 GHz. The ultra-low resistance of these diodes (1.5  $\Omega$  maximum at 1 mA and 0.5  $\Omega$  typical at 10 mA) makes the SMP1322 series particularly suited to low-loss PIN diode switches in battery operated circuits.

The SMP1322 series is available in a selection of plastic packages and a variety of configurations that include the ultra-low inductance SOT-143 (0.2 nH), a small footprint SC-79, and a miniature SC-70. The SMP1322-016 consists of two diodes in an SOT-143 package configured to enable insertion in a quarter-wave transmit/receive (T/R) switch with no crossover connections.

Table 1 describes the various packages and marking of the SMP1322 series.

**Table 1. SMP1322 Series Packaging and Marking**

Single	Common Anode	Common Cathode	Series Pair	Single	T/R Switch	Ultra-Low Inductance	Single
SOT-23	SOT-23	SOT-23	SOT-23	SOD-323 Green™	SOT-143	SOT-143	SC-79 Green™
<b>SMP1322-001</b> Marking: PN1	<b>SMP1322-003</b> Marking: PN9	<b>SMP1322-004</b> Marking: PN3	<b>SMP1322-005</b> Marking: PN2		<b>SMP1322-016</b> Marking: PN6	◆ <b>SMP1322-017</b> Marking: PNF	
<b>SMP1322-001LF</b> Green™ Marking: RN1	<b>SMP1322-003LF</b> Green™ Marking: RN9	<b>SMP1322-004LF</b> Green™ Marking: RN3	<b>SMP1322-005LF</b> Green™ Marking: RN2	<b>SMP1322-011LF</b> Marking: RN	<b>SMP1322-016LF</b> Marking: RN6	◆ <b>SMP1322-017LF</b> Marking: RNF	<b>SMP1322-079LF</b>
L <sub>S</sub> = 1.5 nH	L <sub>S</sub> = 1.5 nH	L <sub>S</sub> = 1.5 nH	L <sub>S</sub> = 1.5 nH	L <sub>S</sub> = 1.5 nH	L <sub>S</sub> = 1.5 nH	L <sub>S</sub> = 0.2 nH	L <sub>S</sub> = 0.7 nH
		SC-70					
		<b>SMP1322-074</b> Marking: PN3					
		<b>SMP1322-074LF</b> Marking: RN3					
		L <sub>S</sub> = 1.4 nH					



The Pb-free symbol or "LF" in the part number denotes a lead-free, RoHS-compliant package unless otherwise noted as Green™. Tin/lead (Sn/Pb) packaging is not recommended for new designs.



**Innovation to Go™**  
Select Linear Products (indicated by ◆) now available for purchase online.

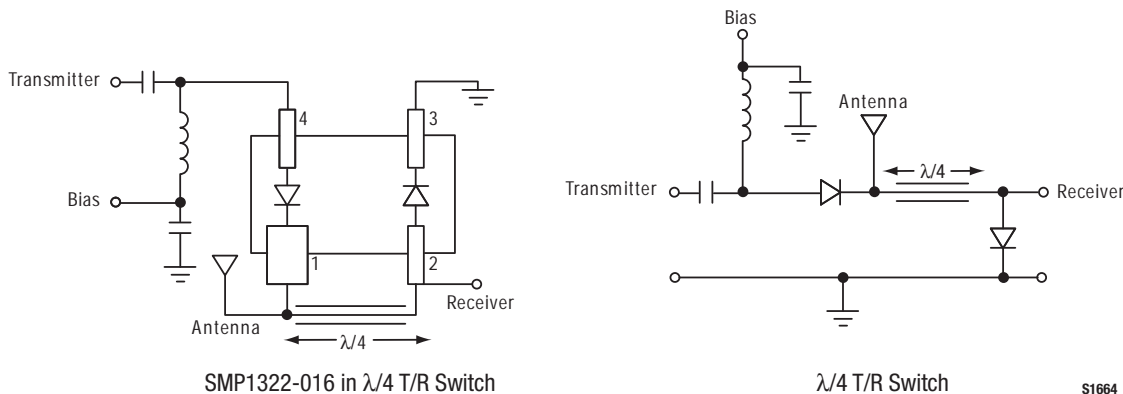

**Figure 1. SMP1322-016 Quarter-Wave T/R Switch**

**SMP1322-016 T/R Switch**

The SMP1322-016 is a low-cost PIN diode unconnected pair specifically designed for low-current drain antenna T/R switches in hand-held wireless systems. In the specifically configured SOT-143 package (see Figure 1), the PIN diodes are oriented to enable connection as a  $\lambda/4$  switch with no external crossover connections.

**SMP1322-017 Low Inductance PIN Diode**

The SMP1322-017 uses the SMP1322 PIN diode chip in a customized SOT-143 plastic package designed for high-isolation performance in a shunt connected switch (see Figure 2). Its effective inductance, based on a 3 GHz isolation, is less than 0.2 nH. This diode is designed to work effectively as a shunt element in SPDT switches, covering the wireless frequencies from 900 MHz to over 2 GHz.

Excellent performance is achieved when the SMP1322-017 is used in a  $\lambda/4$  T/R switch with either the SMP1322-001 (SOT-23 package) or the SMP1322-011 (SOD-323 package) as the series connected PIN diode. Refer to Figure 7.

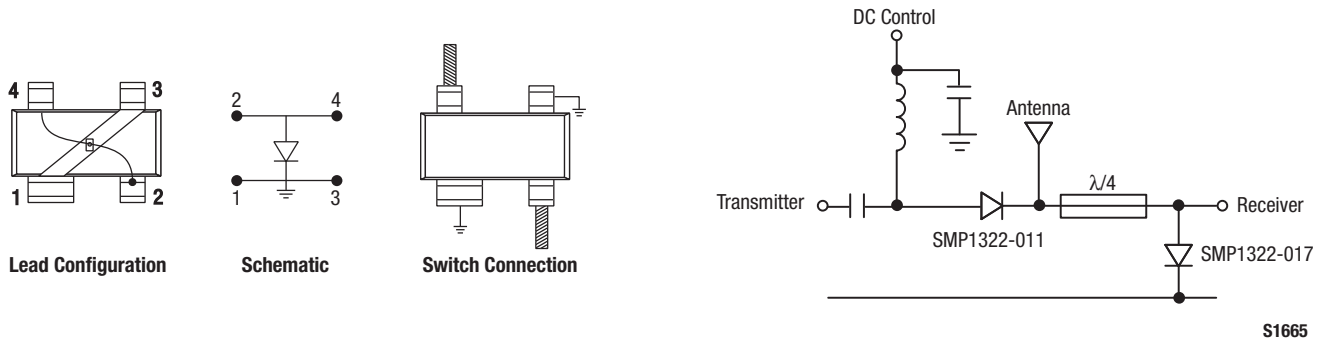

Figure 2. SOT-143 Package and Switch Design

Table 2. SMP1322 Series Absolute Maximum Ratings

Parameter	Symbol	Minimum	Maximum	Units
Reverse voltage	$V_R$		50	V
Power dissipation @ 25 °C lead temperature	$P_D$		250	mW
Storage temperature	$T_{STG}$	-65	+150	°C
Operating temperature	$T_A$	-65	+150	°C

**Note:** Exposure to maximum rating conditions for extended periods may reduce device reliability. There is no damage to device with only one parameter set at the limit and all other parameters set at or below their nominal value. Exceeding any of the limits listed here may result in permanent damage to the device.

**CAUTION:** Although this device is designed to be as robust as possible, Electrostatic Discharge (ESD) can damage this device. This device must be protected at all times from ESD. Static charges may easily produce potentials of several kilovolts on the human body or equipment, which can discharge without detection. Industry-standard ESD precautions should be used at all times. The SMP1322 series PIN diodes are Class 1B ESD devices.

### Electrical and Mechanical Specifications

The absolute maximum ratings of the SMP1322 series are provided in Table 2. Electrical specifications are provided in Table 3. Resistance versus temperature measurements are provided in Table 4.

Typical performance characteristics of the SMP1322 series are illustrated in Figures 3 to 7. Package dimensions are shown in Figures 8 to 16 (even numbers), and tape and reel dimensions are provided in Figures 9 to 17 (odd numbers).

### Package and Handling Information

Instructions on the shipping container label regarding exposure to moisture after the container seal is broken must be followed.

Otherwise, problems related to moisture absorption may occur when the part is subjected to high temperature during solder assembly.

The SMP1322 series is rated to Moisture Sensitivity Level 1 (MSL1) at 260 °C. It can be used for lead or lead-free soldering. For additional information, refer to the Skyworks Application Note, *Solder Reflow Information*, document number 200164

Care must be taken when attaching this product, whether it is done manually or in a production solder reflow environment. Production quantities of this product are shipped in a standard tape and reel format. For packaging details, refer to the Skyworks Application Note *Discrete Devices and IC Switch/Attenuators Tape and Reel Package Orientation*, document number 200083.

**Table 3. SMP1322 Series Electrical Specifications (Note 1)**  
 (T<sub>A</sub> = +25 °C, Unless Otherwise Noted)

Parameter	Symbol	Test Condition	Min	Typical	Max	Units
Reverse current	I <sub>R</sub>	V <sub>R</sub> = 50 V			10	μA
Capacitance (Note 2)	C <sub>T</sub>	F = 1 MHz, V = 30 V			1	pF
Resistance	R <sub>S</sub>	F = 100 MHz I = 1 mA I = 10 mA		0.5	1.5	Ω Ω
Forward voltage	V <sub>F</sub>	I <sub>F</sub> = 10 mA		0.85		V
Carrier lifetime	TI	I <sub>F</sub> = 10 mA		0.4		μs
I region width				8		μm

**Note 1:** Performance is guaranteed only under the conditions listed in this Table.

**Note 2:** C<sub>T</sub> is 1.15 pF maximum for the SMP1322-016, SMP1322-017, and SMP1322-017LF.

**Table 4. Resistance vs Temperature @ 500 MHz**

I <sub>F</sub> (mA)	R <sub>S</sub> @ -55 °C (Ω)	R <sub>S</sub> @ -15 °C (Ω)	R <sub>S</sub> @ +25 °C (Ω)	R <sub>S</sub> @ +65 °C (Ω)	R <sub>S</sub> @ +100 °C (Ω)
0.02	9.5	9.4	9.9	10.5	10.9
0.10	3.0	3.0	3.0	3.3	3.5
0.30	1.5	1.5	1.5	1.6	1.8
0.50	1.1	1.1	1.2	1.2	1.4
1.0	0.922	0.914	0.902	0.963	1.100
10	0.568	0.559	0.533	0.563	0.655
20	0.532	0.520	0.494	0.521	0.610
100	0.483	0.469	0.440	0.464	0.565

**Typical Performance Characteristics**

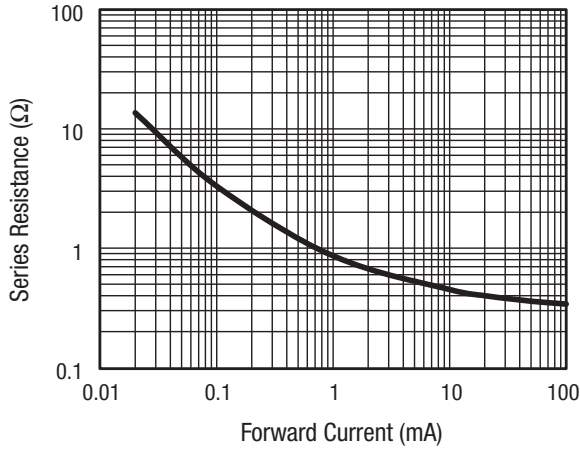

**Figure 3. Series Resistance vs Current @ 100 MHz**

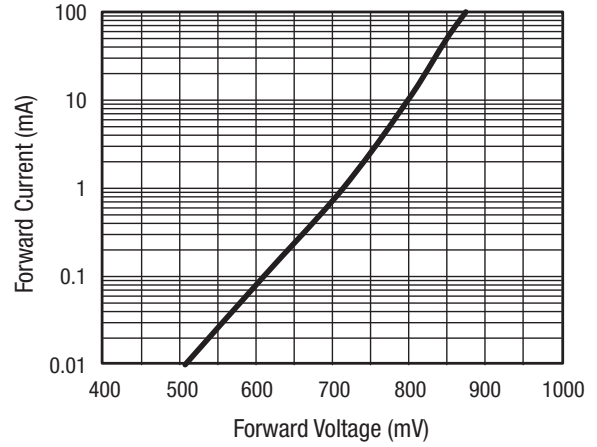

**Figure 4. DC Characteristics**

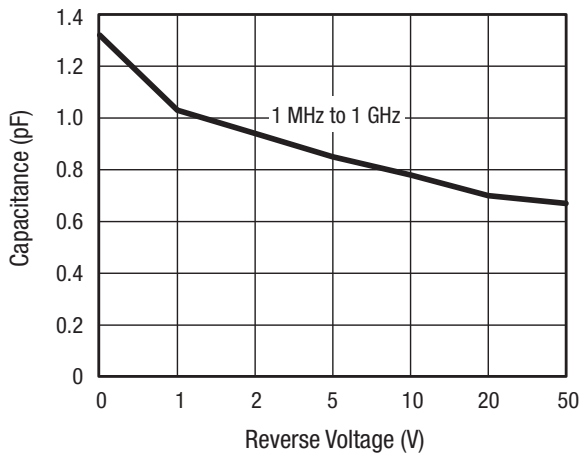

**Figure 5. Capacitance vs Reverse Voltage**

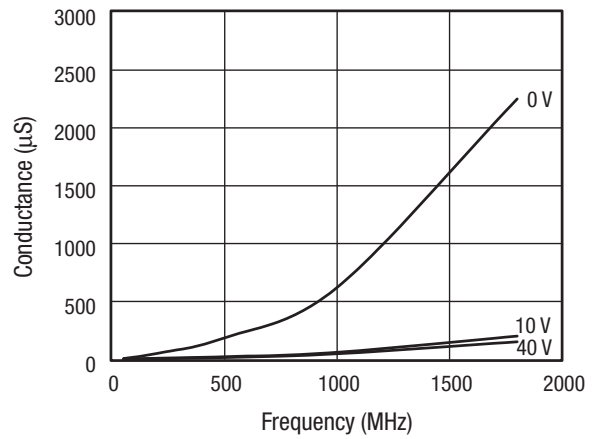

**Figure 6. Conductance vs Frequency and Reverse Voltage**

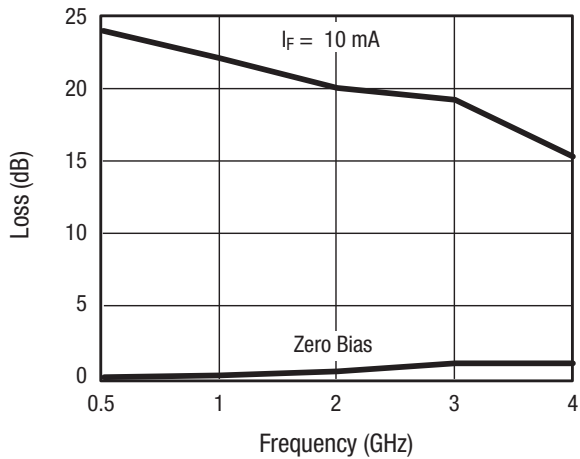

**Figure 7. SMP1322-017 Typical SPST Switch Performance**

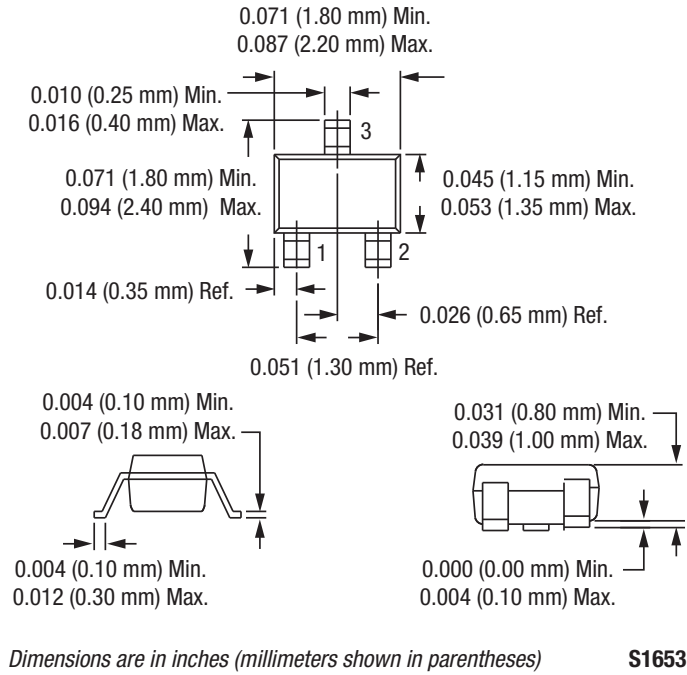

Figure 8. SC-70 Package Dimension Drawing

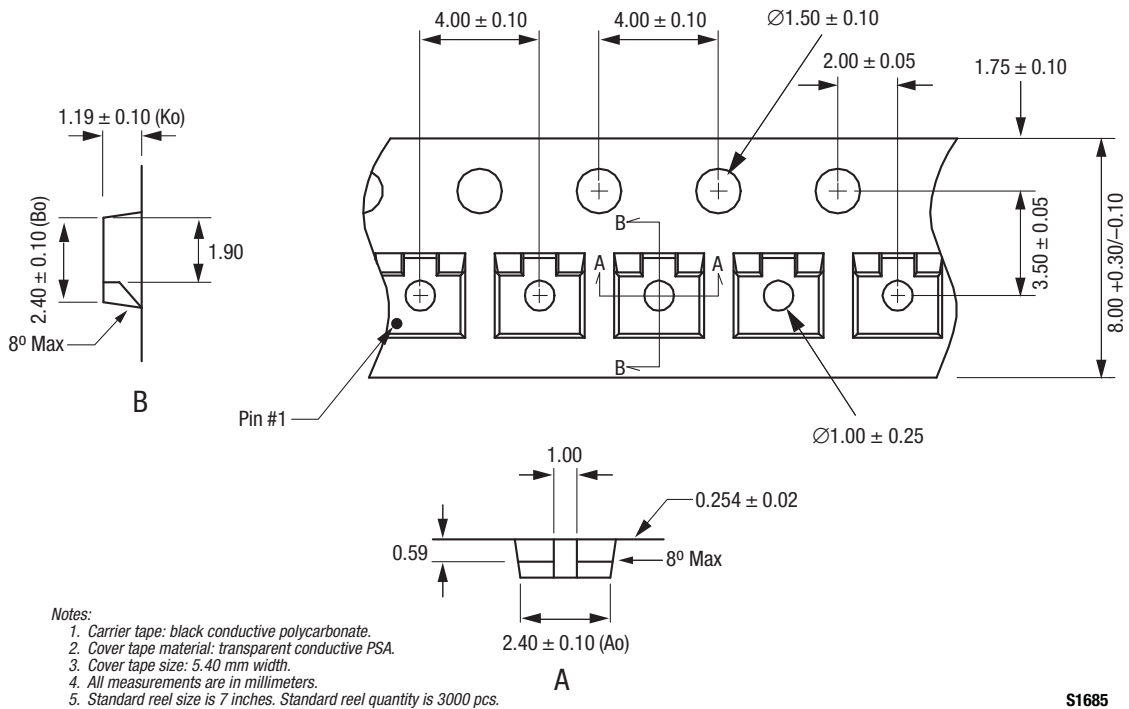
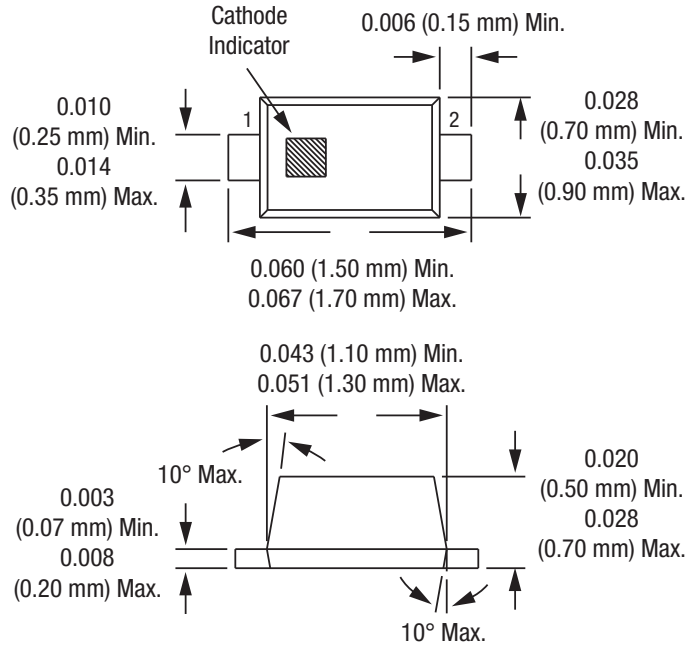
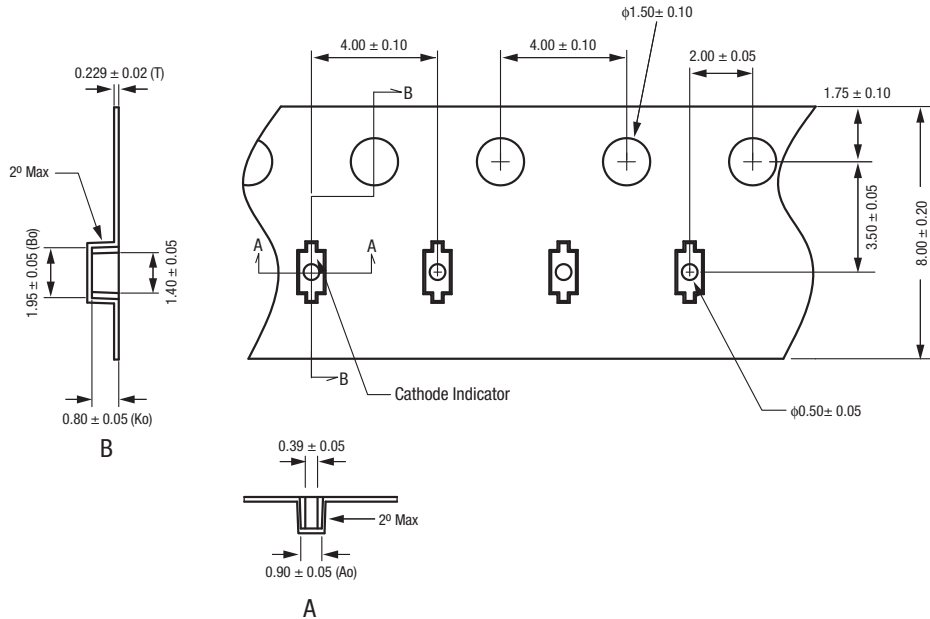

Figure 9. SC-70 Tape and Reel Dimensions



Dimensions are in inches (millimeters shown in parentheses) **S1652**

**Figure 10. SC-79 Package Dimension Drawing**



- Notes:
1. Carrier tape: black conductive polycarbonate or polystyrene.
  2. Cover tape material: transparent conductive PSA.
  3. Cover tape size: 5.4 mm width.
  4. All measurements are in millimeters.
  5. Standard reel size is 7 inches. Standard reel quantity is 3000 pcs.

S1673

**Figure 11. SC-79 Tape and Reel Dimensions**

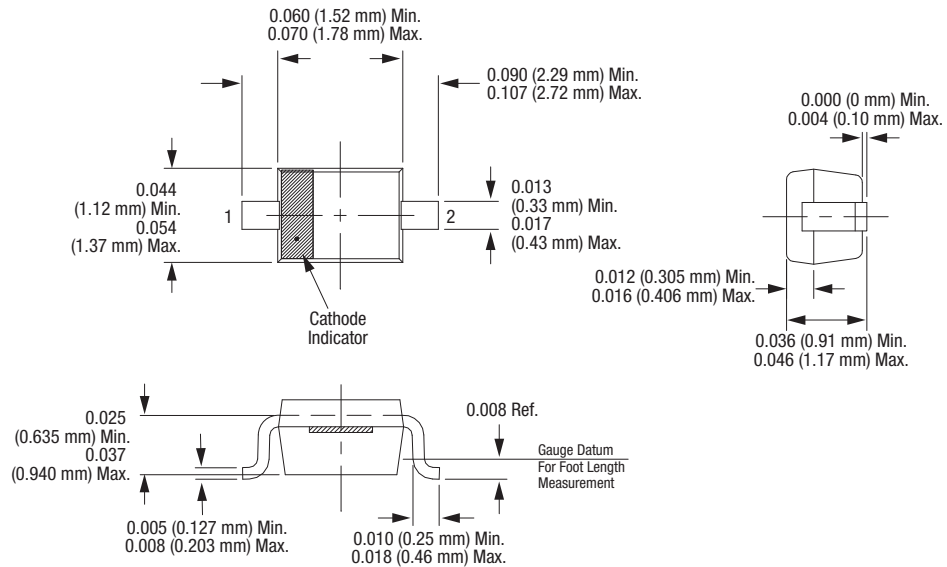

Dimensions are in inches (millimeters shown in parentheses)

S1619

Figure 12. SOD-323 Package Dimension Drawing

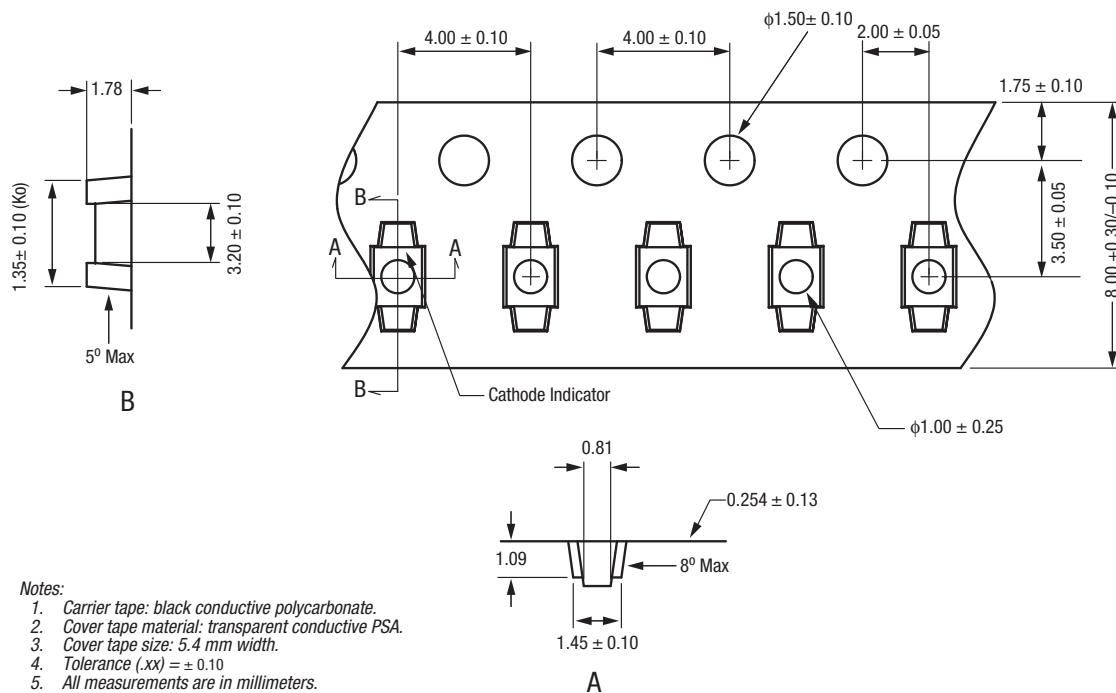

Notes:

1. Carrier tape: black conductive polycarbonate.
2. Cover tape material: transparent conductive PSA.
3. Cover tape size: 5.4 mm width.
4. Tolerance (.xx) = ± 0.10
5. All measurements are in millimeters.
6. Standard reel size is 7 inches. Standard reel quantity is 3000 pcs.

S1674

Figure 13. SOD-323 Tape and Reel Dimensions



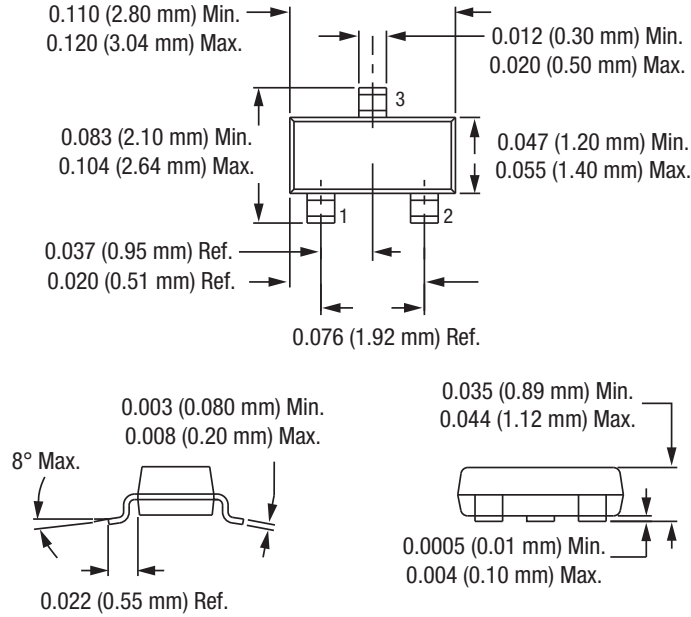

Dimensions are in inches (millimeters shown in parentheses)

S1389

Figure 14. SOT-23 Package Dimension Drawing

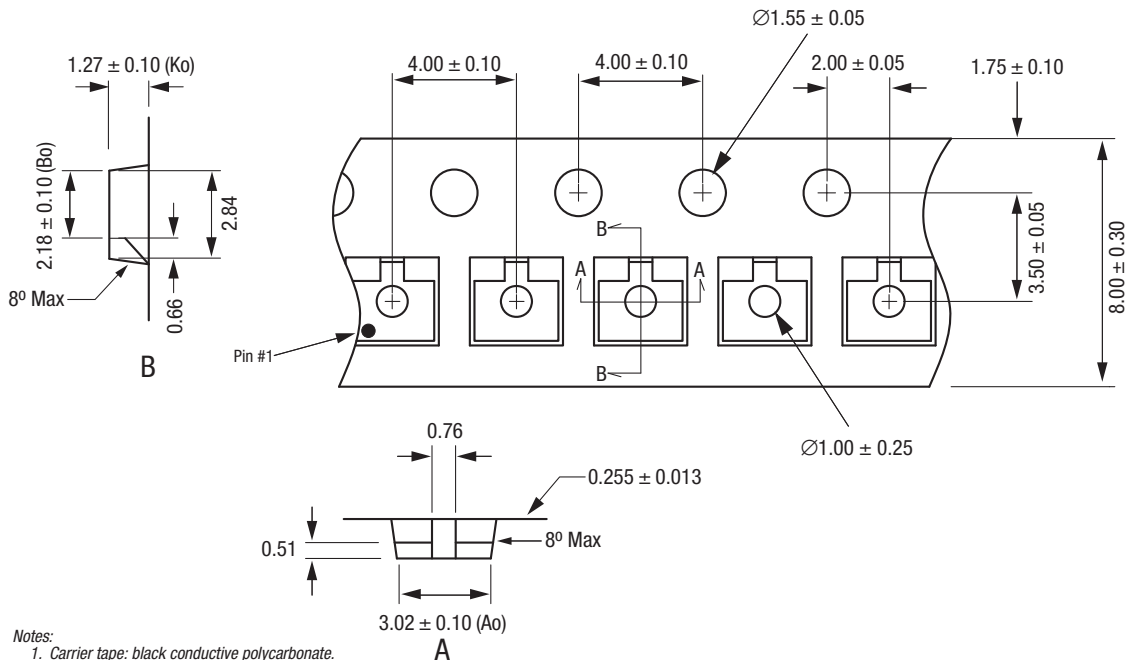

Notes:

1. Carrier tape: black conductive polycarbonate.
2. Cover tape material: transparent conductive PSA.
3. Cover tape size: 5.40 mm width.
4. Tolerance  $\pm 0.10$  mm.
5. All measurements are in millimeters.
6. Standard reel size is 7 inches. Standard reel quantity is 3000 pcs.

S1684

Figure 15. SOT-23 Tape and Reel Dimensions

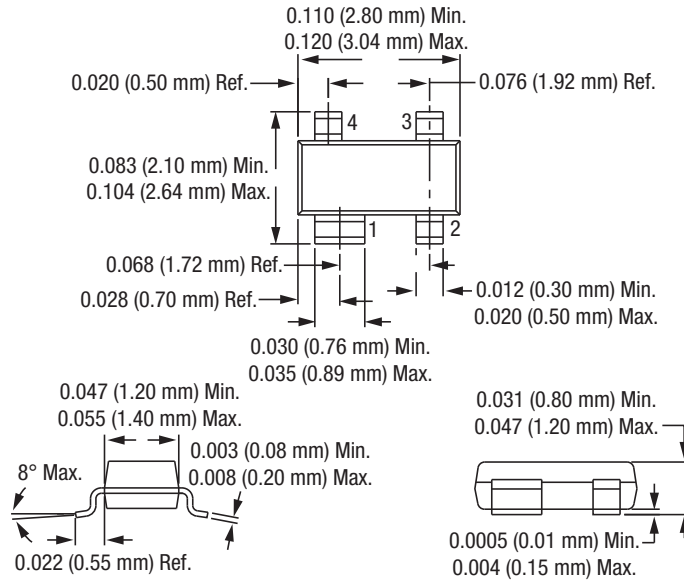

Dimensions are in inches (millimeters shown in parentheses) **S1651**

**Figure 16. SOT-143 Package Dimension Drawing**

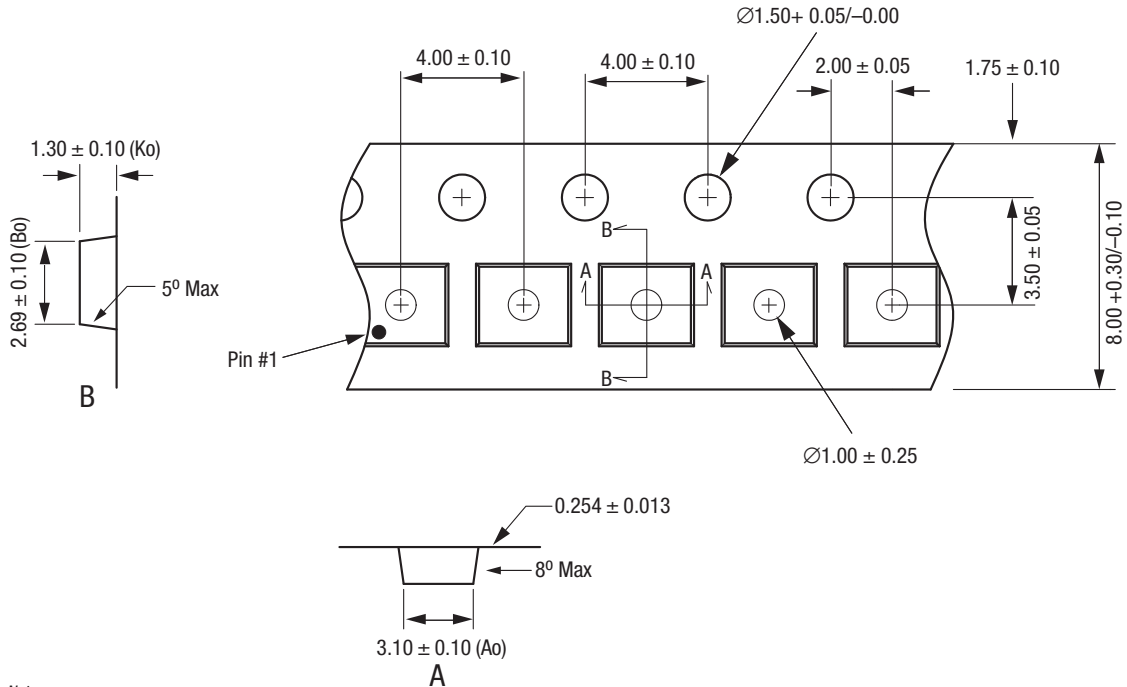

- Notes:
1. Carrier tape: black conductive polycarbonate.
  2. Cover tape material: transparent conductive PSA.
  3. Cover tape size: 5.40 mm width.
  4. Tolerance  $\pm 0.10$  mm.
  5. All measurements are in millimeters.
  6. Standard reel size is 7 inches. Standard reel quantity is 3000 pcs.

**S1683**

**Figure 17. SOT-143 Tape and Reel Dimensions**

Copyright © 2009, 2010 Skyworks Solutions, Inc. All Rights Reserved.

Information in this document is provided in connection with Skyworks Solutions, Inc. ("Skyworks") products or services. These materials, including the information contained herein, are provided by Skyworks as a service to its customers and may be used for informational purposes only by the customer. Skyworks assumes no responsibility for errors or omissions in these materials or the information contained herein. Skyworks may change its documentation, products, services, specifications or product descriptions at any time, without notice. Skyworks makes no commitment to update the materials or information and shall have no responsibility whatsoever for conflicts, incompatibilities, or other difficulties arising from any future changes.

No license, whether express, implied, by estoppel or otherwise, is granted to any intellectual property rights by this document. Skyworks assumes no liability for any materials, products or information provided hereunder, including the sale, distribution, reproduction or use of Skyworks products, information or materials, except as may be provided in Skyworks Terms and Conditions of Sale.

THE MATERIALS, PRODUCTS AND INFORMATION ARE PROVIDED "AS IS" WITHOUT WARRANTY OF ANY KIND, WHETHER EXPRESS, IMPLIED, STATUTORY, OR OTHERWISE, INCLUDING FITNESS FOR A PARTICULAR PURPOSE OR USE, MERCHANTABILITY, PERFORMANCE, QUALITY OR NON-INFRINGEMENT OF ANY INTELLECTUAL PROPERTY RIGHT; ALL SUCH WARRANTIES ARE HEREBY EXPRESSLY DISCLAIMED. SKYWORKS DOES NOT WARRANT THE ACCURACY OR COMPLETENESS OF THE INFORMATION, TEXT, GRAPHICS OR OTHER ITEMS CONTAINED WITHIN THESE MATERIALS. SKYWORKS SHALL NOT BE LIABLE FOR ANY DAMAGES, INCLUDING BUT NOT LIMITED TO ANY SPECIAL, INDIRECT, INCIDENTAL, STATUTORY, OR CONSEQUENTIAL DAMAGES, INCLUDING WITHOUT LIMITATION, LOST REVENUES OR LOST PROFITS THAT MAY RESULT FROM THE USE OF THE MATERIALS OR INFORMATION, WHETHER OR NOT THE RECIPIENT OF MATERIALS HAS BEEN ADVISED OF THE POSSIBILITY OF SUCH DAMAGE.

Skyworks products are not intended for use in medical, lifesaving or life-sustaining applications, or other equipment in which the failure of the Skyworks products could lead to personal injury, death, physical or environmental damage. Skyworks customers using or selling Skyworks products for use in such applications do so at their own risk and agree to fully indemnify Skyworks for any damages resulting from such improper use or sale.

Customers are responsible for their products and applications using Skyworks products, which may deviate from published specifications as a result of design defects, errors, or operation of products outside of published parameters or design specifications. Customers should include design and operating safeguards to minimize these and other risks. Skyworks assumes no liability for applications assistance, customer product design, or damage to any equipment resulting from the use of Skyworks products outside of stated published specifications or parameters.

Skyworks, the Skyworks symbol, and "Breakthrough Simplicity" are trademarks or registered trademarks of Skyworks Solutions, Inc., in the United States and other countries. Third-party brands and names are for identification purposes only, and are the property of their respective owners. Additional information, including relevant terms and conditions, posted at [www.skyworksinc.com](http://www.skyworksinc.com), are incorporated by reference.