

DATA SHEET

# SMP1345 Series: Very Low Capacitance, Plastic Packaged Silicon PIN Diodes

## Applications

- High isolation LNBs, WLANs, and wireless switches

## Features

- Very low insertion loss: 0.4 dB
- Capacitance: 0.15 pF
- Packages rated MSL1, 260 °C per JEDEC J-STD-020



**NEW** Skyworks Green™ products are RoHS (Restriction of Hazardous Substances)-compliant, conform to the EIA/EICTA/JEITA Joint Industry Guide (JIG) Level A guidelines, are halogen free according to IEC-61249-2-21, and contain <1,000 ppm antimony trioxide in polymeric materials.







## Description

The SMP1345 series of plastic packaged, surface mountable PIN diodes is designed for high volume Low-Noise Block (LNB), Wireless Local Area Network (WLAN), and switch applications from 10 MHz to 6 GHz. The short carrier lifetime of 100 ns (typical), combined with their thin I-region width of 10 μm (nominal) results in a group of fast speed RF switching PIN diodes.

The RF performance of the SMP1345 series is assured by virtue of their very low capacitance (0.15 pF) and low resistance (1.5 Ω at 10 mA). The SMP1345-518 has been specifically designed for WLAN 802.11 a/b/g applications. It is ideally suited for diversity switch applications.

Table 1 describes the various packages and marking of the SMP1345 series.

**Table 1. SMP1345 Series Packaging and Marking**

				
Common Anode	Common Cathode	Series Pair	Single	Ring
SOT-23	SOT-23	SOT-23	SC-79 Green™	LGA Green™
<b>SMP1345-003</b> Marking: PU9	<b>SMP1345-004</b> Marking: PU3	<b>SMP1345-005</b> Marking: PU2		◆ <b>SMP1345-518</b> Marking: 0 Pb-Free
<b>SMP1345-003LF</b> Green™ Marking: RU9	<b>SMP1345-004LF</b> Green™ Marking: RU3	<b>SMP1345-005LF</b> Green™ Marking: RU2	<b>SMP1345-079LF</b>	
$L_S = 1.5 \text{ nH}$	$L_S = 1.5 \text{ nH}$	$L_S = 1.5 \text{ nH}$	$L_S = 0.7 \text{ nH}$	$L_S = 0.6 \text{ nH}$
		SC-70		
		<b>SMP1345-075LF</b> Marking: RU2		
		$L_S = 1.4 \text{ nH}$		



The Pb-free symbol or "LF" in the part number denotes a lead-free, RoHS-compliant package unless otherwise noted as Green™. Tin/lead (Sn/Pb) packaging is not recommended for new designs.



**Innovation to Go™**

Select Linear Products (indicated by ◆) now available for purchase online.

**Table 2. SMP1345 Series Absolute Maximum Ratings**

Parameter	Symbol	Minimum	Maximum	Units
Reverse voltage	$V_R$		50	V
Power dissipation @ 25 °C lead temperature	$P_D$		250	mW
Storage temperature	$T_{STG}$	-65	+150	°C
Operating temperature	$T_A$	-65	+150	°C

**Note:** Exposure to maximum rating conditions for extended periods may reduce device reliability. There is no damage to device with only one parameter set at the limit and all other parameters set at or below their nominal value. Exceeding any of the limits listed here may result in permanent damage to the device.

**CAUTION:** Although this device is designed to be as robust as possible, Electrostatic Discharge (ESD) can damage this device. This device must be protected at all times from ESD. Static charges may easily produce potentials of several kilovolts on the human body or equipment, which can discharge without detection. Industry-standard ESD precautions should be used at all times. The SMP1345 series PIN diodes are Class 1B ESD devices.

### Electrical and Mechanical Specifications

The absolute maximum ratings of the SMP1345 series are provided in Table 2. Electrical specifications are provided in Table 3.

The state of the SMP1345-518 series diode is determined by the logic provided in Table 4. Typical performance characteristics of the SMP1345 series are illustrated in Figures 1 to 5.

**Table 3. SMP1345 Series Electrical Specifications (Note 1)**  
**(T<sub>A</sub> = +25 °C, Unless Otherwise Noted)**

Parameter	Symbol	Test Condition	Min	Typical	Max	Units
Reverse current	I <sub>R</sub>	V <sub>R</sub> = 50 V			10	μA
Capacitance	C <sub>T</sub>	F = 1 MHz		0.19		pF
		V = 1 V V = 5 V		0.18	0.20	pF
Resistance	R <sub>S</sub>	F = 100 MHz		3.5		Ω
		I = 1 mA I = 10 mA		1.5	2.0	Ω
Forward voltage	V <sub>F</sub>	I <sub>F</sub> = 10 mA		0.89		V
Carrier lifetime	TI	I <sub>F</sub> = 10 mA		100		ns
I region width				10		μm

**Note 1:** Performance is guaranteed only under the conditions listed in this Table.

**Table 4. SMP1345-518 PIN Diode Truth Table**

CTR1 (V)	CTR2 (V)	Low Loss Paths
3.3	0	RF1 to RF4 RF2 to RF3
0	3.3	RF1 to RF3 RF2 to RF4

### Typical Performance Characteristics

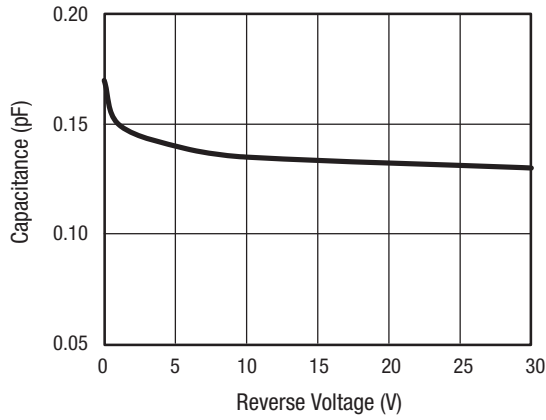

**Figure 1. Total Capacitance vs Reverse Voltage (SC-79 Package Measurement)**

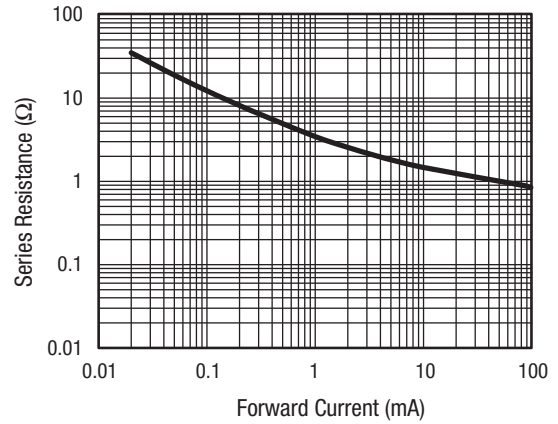

**Figure 2. Series Resistance vs Current @ 100 MHz**

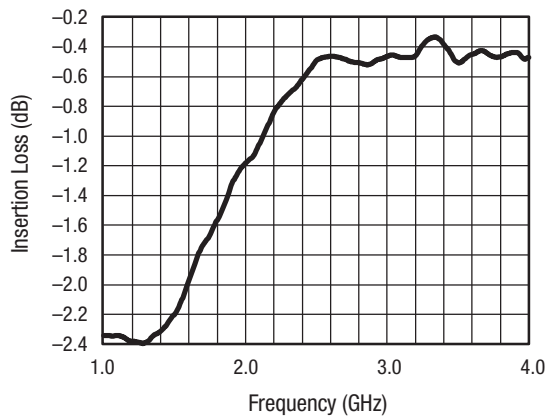

**Figure 3. Insertion Loss vs Frequency**

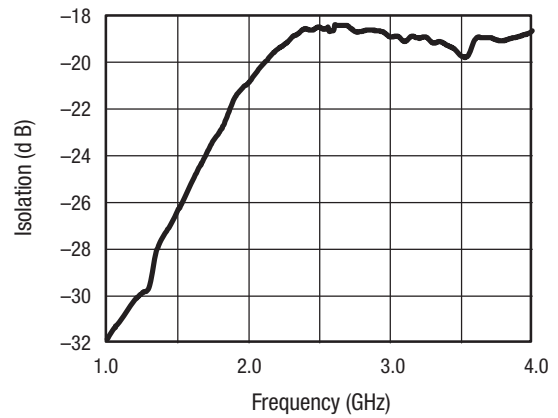

**Figure 4. Isolation vs Frequency**

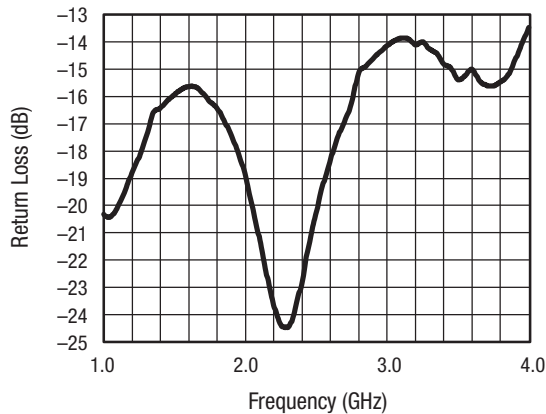

**Figure 5. Return Loss vs Frequency**

**Evaluation Board Description**

An Evaluation Board is used to test the performance of the SMP1345 series PIN diodes. An assembly drawing for the Evaluation Board is shown in Figure 6. A typical application circuit diagram for a DPDT diversity switch using the SMP1345-518 is provided in Figure 7.

**Package and Handling Information**

Package dimensions are shown in Figures 8 to 14 (even numbers), and tape and reel dimensions are provided in Figures 9 to 15 (odd numbers). Instructions on the shipping container label regarding exposure to moisture after the container seal is broken must be followed. Otherwise, problems related to moisture

absorption may occur when the part is subjected to high temperature during solder assembly.

The SMP1345 series is rated to Moisture Sensitivity Level 1 (MSL1) at 260 °C. It can be used for lead or lead-free soldering. For additional information, refer to the Skyworks Application Note, *Solder Reflow Information*, document number 200164

Care must be taken when attaching this product, whether it is done manually or in a production solder reflow environment. Production quantities of this product are shipped in a standard tape and reel format. For packaging details, refer to the Skyworks Application Note *Discrete Devices and IC Switch/Attenuators Tape and Reel Package Orientation*, document number 200083.

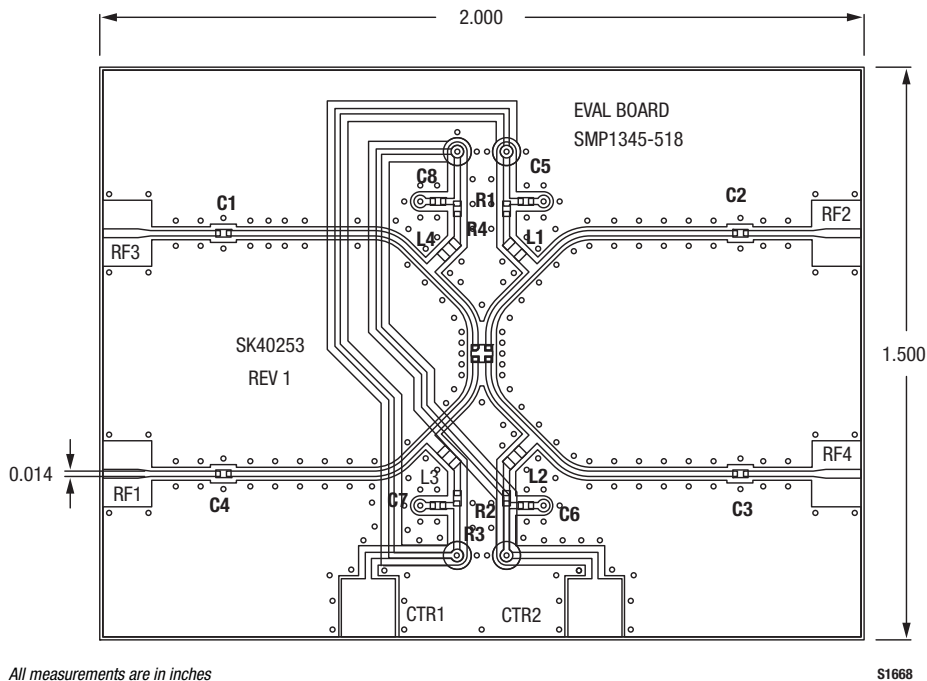

**Figure 6. SMP1345 Series PIN Diode Evaluation Board Assembly Diagram**

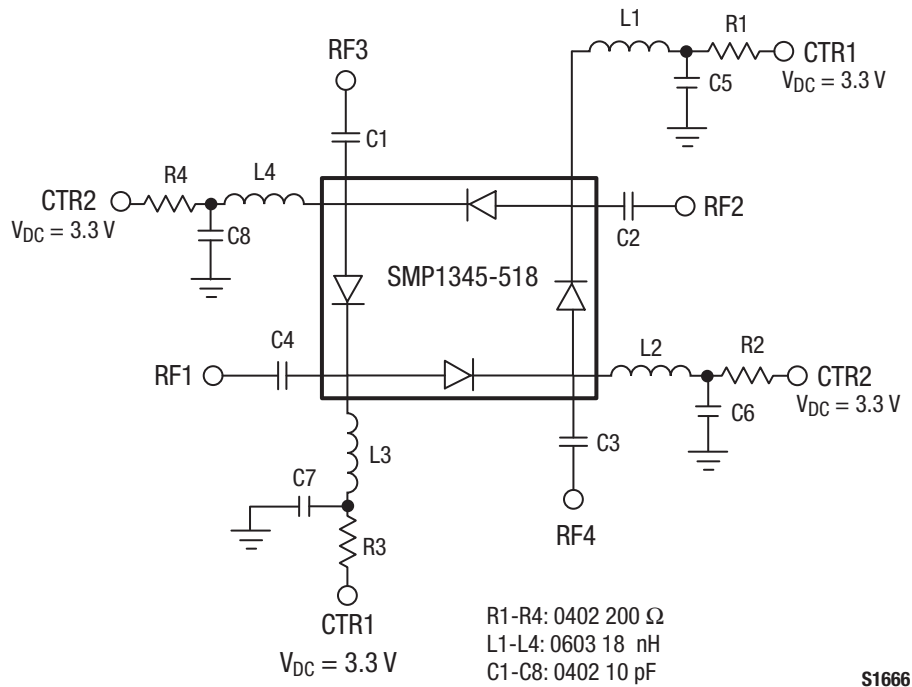

**Figure 7. WLAN Application Circuit for DPDT Diversity Switch Using The SMP1345-518**

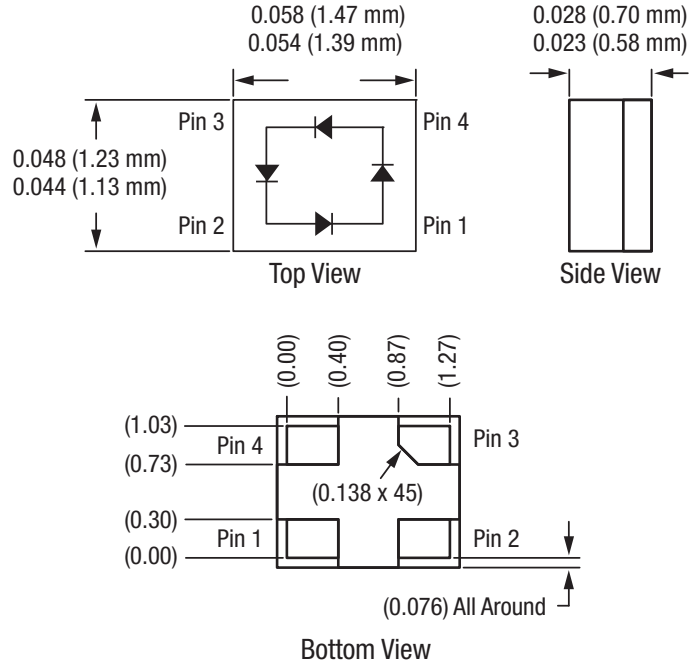

Dimensions are in inches (millimeters shown in parentheses)

S1811

Figure 8. LGA Package Dimension Drawing

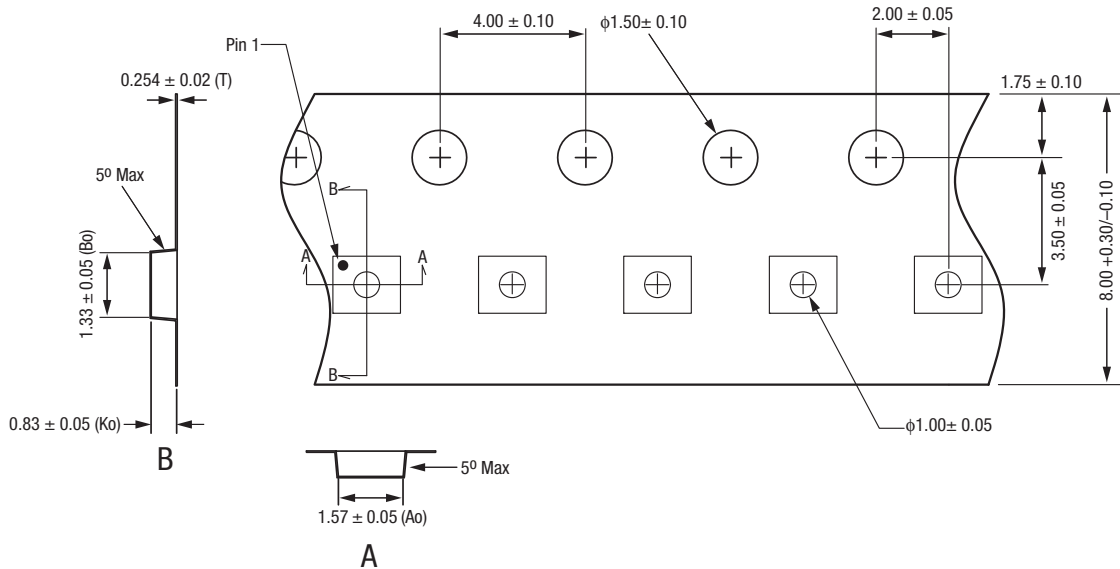

Notes:

1. Carrier tape: black conductive polycarbonate or polystyrene.
2. Cover tape material: transparent conductive PSA.
3. Cover tape size: 5.4 mm width.
4. All measurements are in millimeters.
5. Standard reel size is 7 inches. Standard reel quantity is 3000 pcs.

S1682

Figure 9. LGA Tape and Reel Dimensions

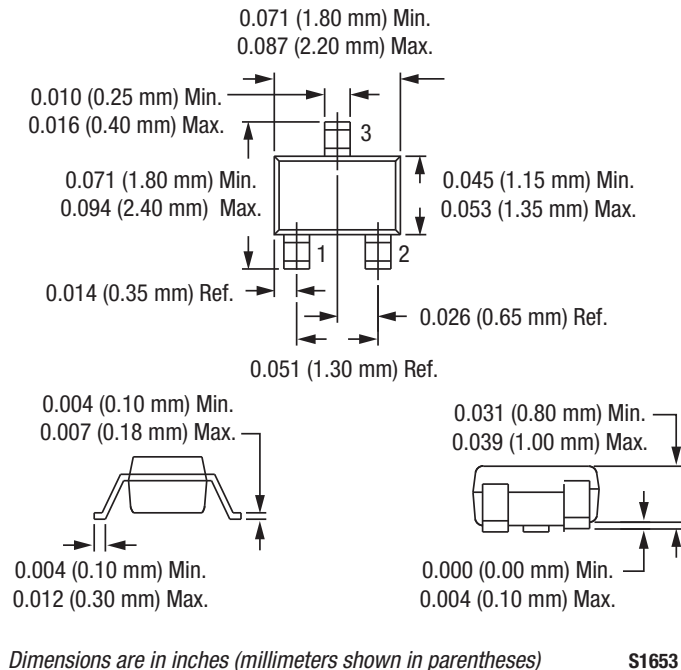

Figure 10. SC-70 Package Dimension Drawing

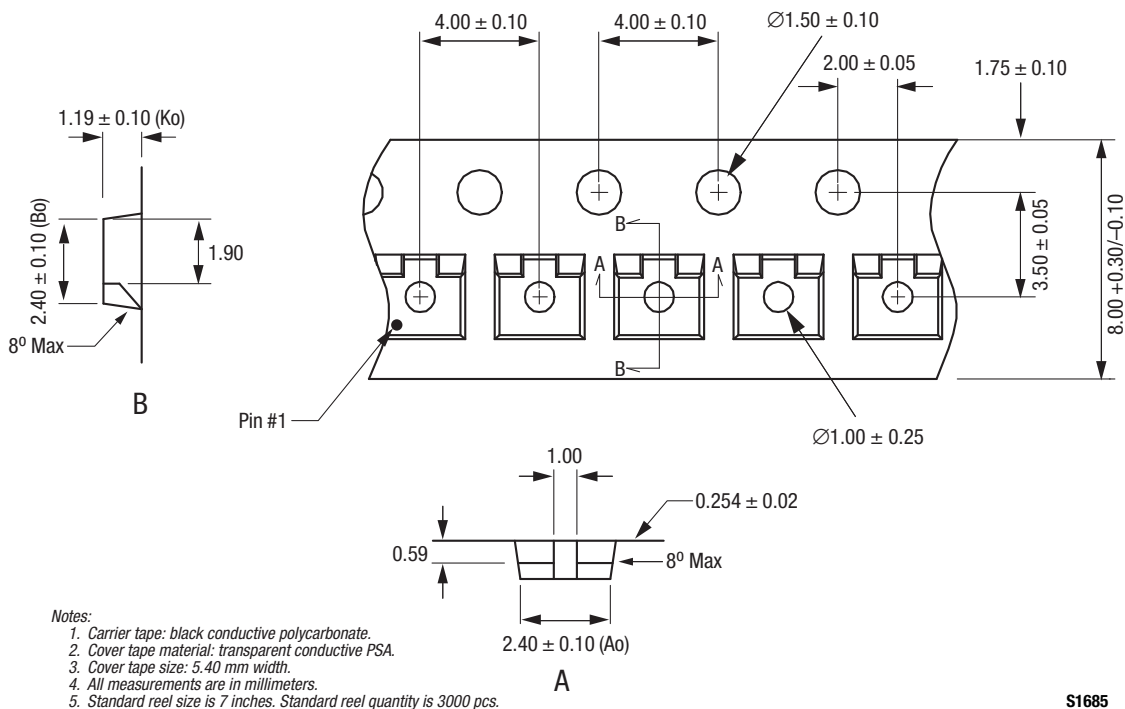
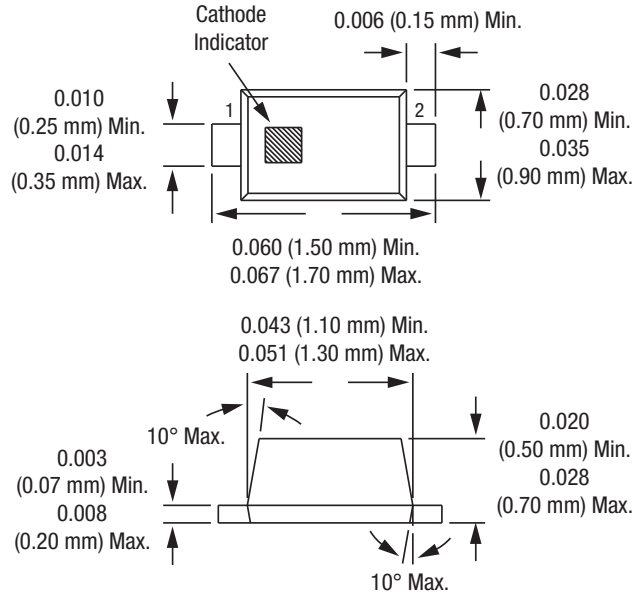

Figure 11. SC-70 Tape and Reel Dimensions





Dimensions are in inches (millimeters shown in parentheses) **S1652**

**Figure 12. SC-79 Package Dimension Drawing**

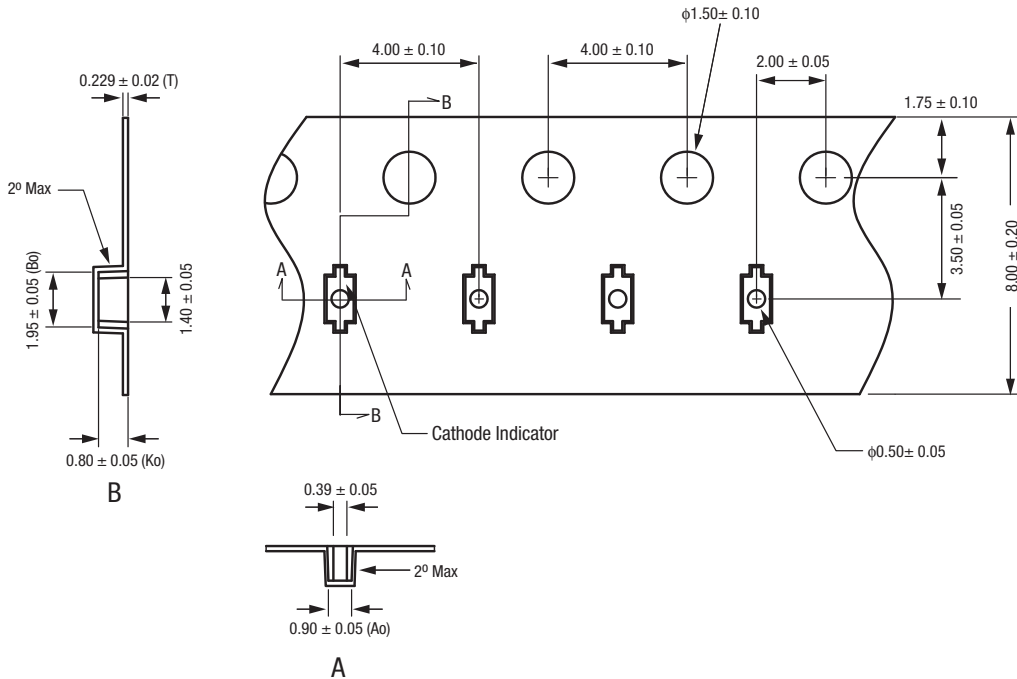

- Notes:
1. Carrier tape: black conductive polycarbonate or polystyrene.
  2. Cover tape material: transparent conductive PSA.
  3. Cover tape size: 5.4 mm width.
  4. All measurements are in millimeters.
  5. Standard reel size is 7 inches. Standard reel quantity is 3000 pcs.

**S1673**

**Figure 13. SC-79 Tape and Reel Dimensions**

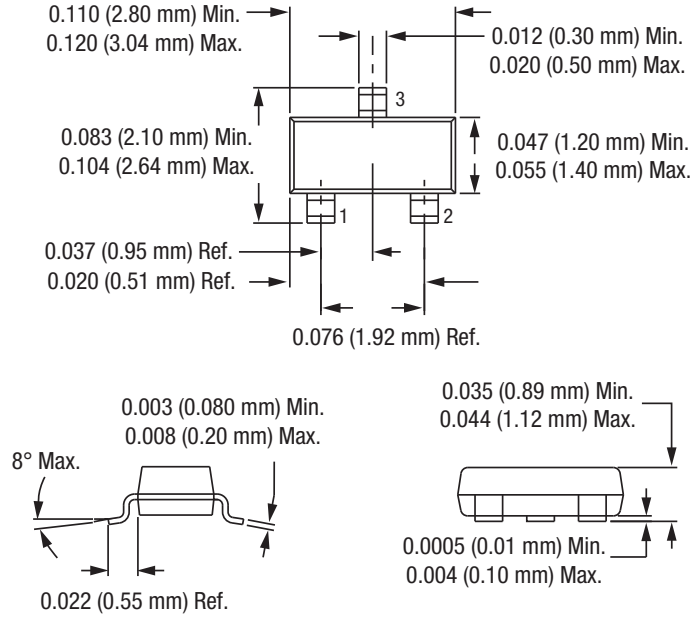

Dimensions are in inches (millimeters shown in parentheses)

S1389

Figure 14. SOT-23 Package Dimension Drawing

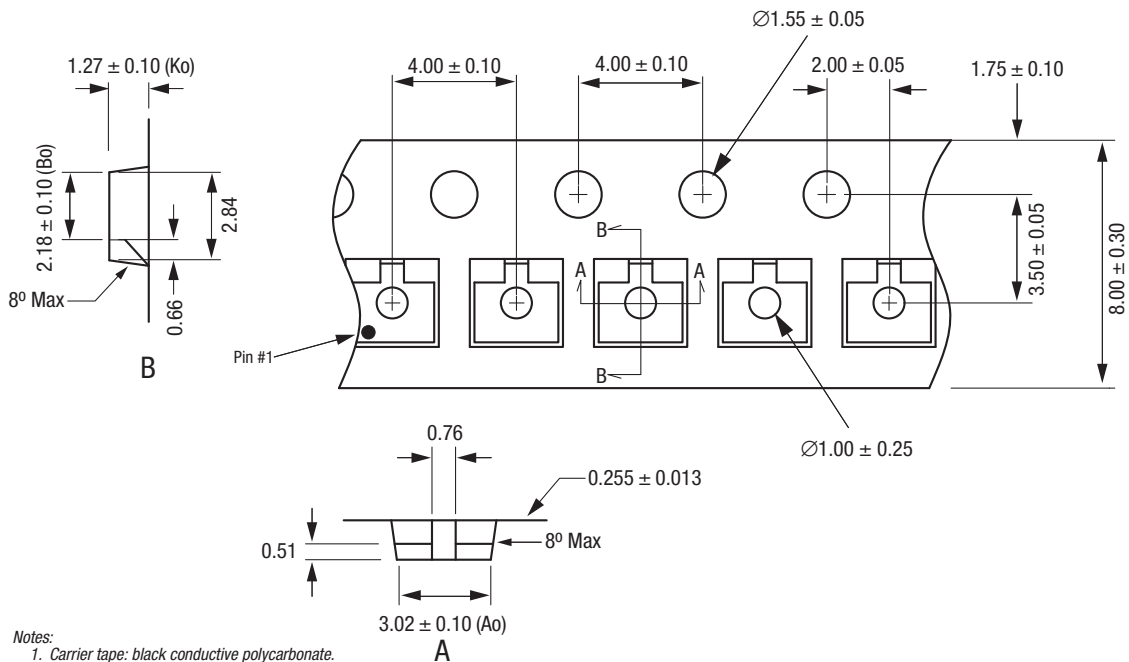

Notes:

1. Carrier tape: black conductive polycarbonate.
2. Cover tape material: transparent conductive PSA.
3. Cover tape size: 5.40 mm width.
4. Tolerance ±0.10 mm.
5. All measurements are in millimeters.
6. Standard reel size is 7 inches. Standard reel quantity is 3000 pcs.

S1684

Figure 15. SOT-23 Tape and Reel Dimensions

Copyright © 2002-2007, 2009, 2010 Skyworks Solutions, Inc. All Rights Reserved.

Information in this document is provided in connection with Skyworks Solutions, Inc. ("Skyworks") products or services. These materials, including the information contained herein, are provided by Skyworks as a service to its customers and may be used for informational purposes only by the customer. Skyworks assumes no responsibility for errors or omissions in these materials or the information contained herein. Skyworks may change its documentation, products, services, specifications or product descriptions at any time, without notice. Skyworks makes no commitment to update the materials or information and shall have no responsibility whatsoever for conflicts, incompatibilities, or other difficulties arising from any future changes.

No license, whether express, implied, by estoppel or otherwise, is granted to any intellectual property rights by this document. Skyworks assumes no liability for any materials, products or information provided hereunder, including the sale, distribution, reproduction or use of Skyworks products, information or materials, except as may be provided in Skyworks Terms and Conditions of Sale.

THE MATERIALS, PRODUCTS AND INFORMATION ARE PROVIDED "AS IS" WITHOUT WARRANTY OF ANY KIND, WHETHER EXPRESS, IMPLIED, STATUTORY, OR OTHERWISE, INCLUDING FITNESS FOR A PARTICULAR PURPOSE OR USE, MERCHANTABILITY, PERFORMANCE, QUALITY OR NON-INFRINGEMENT OF ANY INTELLECTUAL PROPERTY RIGHT; ALL SUCH WARRANTIES ARE HEREBY EXPRESSLY DISCLAIMED. SKYWORKS DOES NOT WARRANT THE ACCURACY OR COMPLETENESS OF THE INFORMATION, TEXT, GRAPHICS OR OTHER ITEMS CONTAINED WITHIN THESE MATERIALS. SKYWORKS SHALL NOT BE LIABLE FOR ANY DAMAGES, INCLUDING BUT NOT LIMITED TO ANY SPECIAL, INDIRECT, INCIDENTAL, STATUTORY, OR CONSEQUENTIAL DAMAGES, INCLUDING WITHOUT LIMITATION, LOST REVENUES OR LOST PROFITS THAT MAY RESULT FROM THE USE OF THE MATERIALS OR INFORMATION, WHETHER OR NOT THE RECIPIENT OF MATERIALS HAS BEEN ADVISED OF THE POSSIBILITY OF SUCH DAMAGE.

Skyworks products are not intended for use in medical, lifesaving or life-sustaining applications, or other equipment in which the failure of the Skyworks products could lead to personal injury, death, physical or environmental damage. Skyworks customers using or selling Skyworks products for use in such applications do so at their own risk and agree to fully indemnify Skyworks for any damages resulting from such improper use or sale.

Customers are responsible for their products and applications using Skyworks products, which may deviate from published specifications as a result of design defects, errors, or operation of products outside of published parameters or design specifications. Customers should include design and operating safeguards to minimize these and other risks. Skyworks assumes no liability for applications assistance, customer product design, or damage to any equipment resulting from the use of Skyworks products outside of stated published specifications or parameters.

Skyworks, the Skyworks symbol, and "Breakthrough Simplicity" are trademarks or registered trademarks of Skyworks Solutions, Inc., in the United States and other countries. Third-party brands and names are for identification purposes only, and are the property of their respective owners. Additional information, including relevant terms and conditions, posted at [www.skyworksinc.com](http://www.skyworksinc.com), are incorporated by reference.