

Micro Commercial Components Corp.

Products End of Life Notification

Issue date: Oct-20th-2008

Last Buy Date : Dec-31th-2008

Description and Purpose:

MCC has undergone a review of its core business and products , and

determined to discontinue below products:

Discontinued Devices	Possible Replacements
TSMBJ1024C	None
TSMBJ1022C	None
TSMBJ1018C	None
TSMBJ1016C	None
TSMBJ1012C	None
TSMBJ1010C	None
TSMBJ1009C-130	None
TSMBJ1007C	None
TSMBJ1006C	None
TSMBJ1005C-072	None
TSMBJ1005C-064	None
TSMBJ0524C	None
TSMBJ0522C	None
TSMBJ0518C	None
TSMBJ0516C	None
TSMBJ0512C	None
TSMBJ0510C	None
TSMBJ0509C-130	None



Micro Commercial Components™

Discontinued Devices	Possible Replacements
TSMBJ0507C	None
TSMBJ0506C	None
TSMBJ0505C-072	None
TSMBJ0505C-064	None
TSMBJ0324C	None
TSMBJ0322C	None
TSMBJ0318C	None
TSMBJ0316C	None
TSMBJ0312C	None
TSMBJ0310C	None
TSMBJ0309C-130	None
TSMBJ0307C	None
TSMBJ0306C	None
TSMBJ0305C-072	None
TSMBJ0305C-064	None



Micro Commercial Components

Micro Commercial Components
 20736 Marilla Street Chatsworth
 CA 91311
 Phone: (818) 701-4933
 Fax: (818) 701-4939

TSMBJ050 5C-064

Features

- Oxide-Glass passivated Junction
- Bi-Directional protection in a single device
- Surge capabilities up to 80A@10/1000us or 250A@8/20us
- High Off-State impedance and Low On-State voltage
- Plastic material has UL flammability classification 94V-0

**Transient Voltage
 Protection Device
 58 Volts**

Mechanical Data

- Case : Molded plastic
- Polarity : None cathode band denotes
- Approx Weight : 0.093grams

Maximum Ratings

Characteristic	Symbol	Value	Unit
Non-repetitive peak impulse current	I_{PP}	80A	10/1000us
Non-repetitive peak On-state current	I_{TSM}	30A	8.3ms, one-half cycle
Operating temperature range	T_{OP}	-40~150°C	
Junction and storage temperature range	T_J, T_{STG}	-55~150°C	

Thermal Resistance

Characteristic	Symbol	Value	Unit
Thermal Resistance junction to lead	$R_{\theta JL}$	20°C/W	
Thermal Resistance junction to ambient	$R_{\theta JA}$	100°C/W	On recommended pad layout
Typical positive temperature coefficient for breakdown voltage	$\Delta V_{BR}/\Delta T_J$	0.1%/°C	

**DO-214AA
 (SMB)**

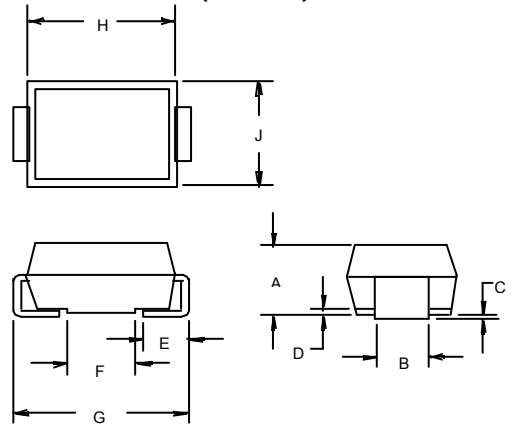

DIM	INCHES		MM		NOTE
	MIN	MAX	MIN	MAX	
A	.078	.096	2.00	2.44	
B	.077	.083	1.96	2.10	
C	.002	.008	.05	.20	
D	—	.02	—	.51	
E	.030	.060	.76	1.52	
F	.065	.091	1.65	2.32	
G	.205	.220	5.21	5.59	
H	.160	.180	4.06	4.57	
J	.130	.155	3.30	3.94	

**SUGGESTED SOLDER
 PAD LAYOUT**

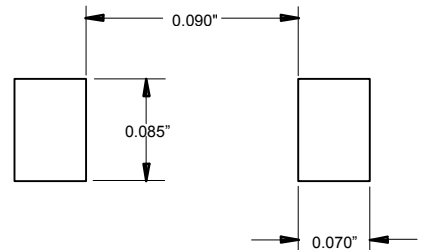

TSMBJ0505C-064



ELECTRICAL CHARACTERISTIC @25°C Unless otherwise specified

Parameter	Rated Repetitive Off-state Voltage	Off-state Leakage Current@V _{DRM}	Breakover Voltage	On-State Voltage @I _T =1.0A	Breakover Current	Holding Current	Off-State Capacitance
Symbol	V _{DRM}	I _{DRM}	V _{BO}	V _T	I _{BO±}	I _H	C _J
Units	Volts	uA	Volts	Volts	mA	mA	pF
Limit	Max	Max	Max	Max	Max	Min	Typ.
TSMBJ0505C-064	58	5	77	5	800	150	140

MAXIMUM RATED SURGE WAVEFORM

Waveform	Standard	I _{pp} (A)
2/10 us	GR-1089-CORE	250
8/20 us	IEC 61000-4-5	250
10/160 us	FCC Part 68	150
10/700 us	ITU-T K20/21	100
10/560 us	FCC Part 68	100
10/1000 us	GR-1089-CORE	80

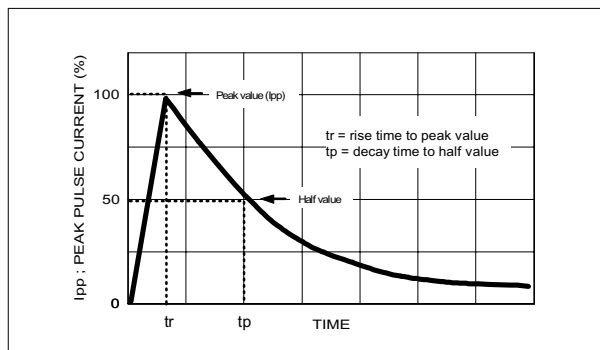

Symbol	Parameter	
V _{DRM}	Stand-off voltage	
I _{DRM}	Leakage current at stand-off voltage	
V _{BR}	Breakdown voltage	
I _{BR}	Breakdown current	
V _{BO}	Breakover voltage	
I _{BO}	Breakover current	
I _H	Holding current	NOTE: 1
V _T	On state voltage	
I _{PP}	Peak pulse current	
C _O	Off-state capacitance	NOTE: 2

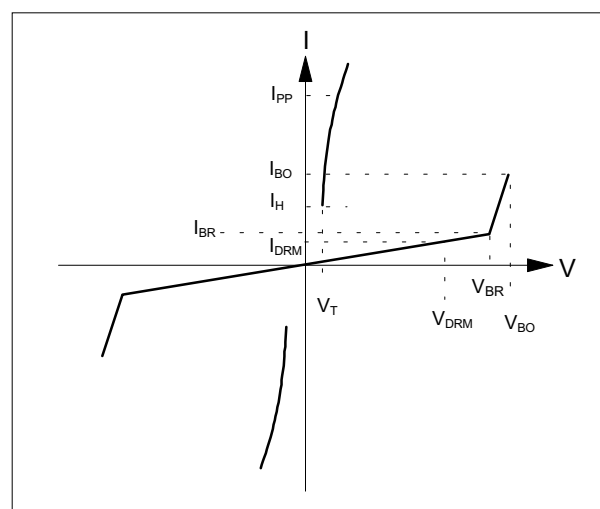

NOTE :

1. $I_H > (V_L / R_L)$ If this criterion is not obeyed, the TSPD triggers but does not return correctly to high-resistance state. The surge recovery time. It does not exceed 30ms.
2. Off-state capacitance measured at f=1.0MHz, 1.0Vrms signal, V_R=2Vdc bias.

TSMBJ0505C-064

Fig.1 - Off-State Current v.s Junction Temperature

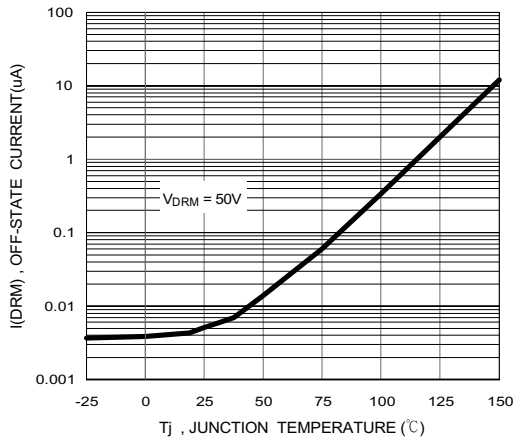

Fig.2 - Relative Variation of Breakdown Voltage v.s Junction Temperature

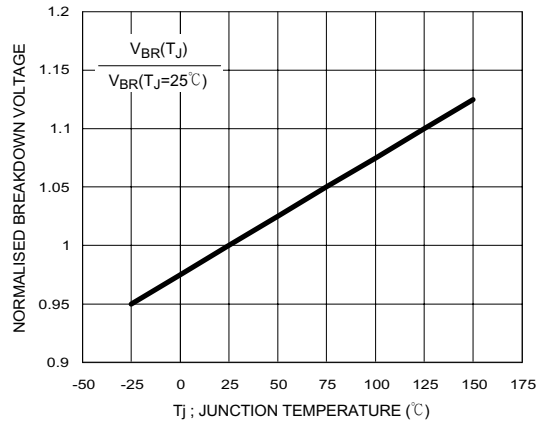

Fig.3 - Relative Variation of Breakover Voltage v.s Junction Temperature

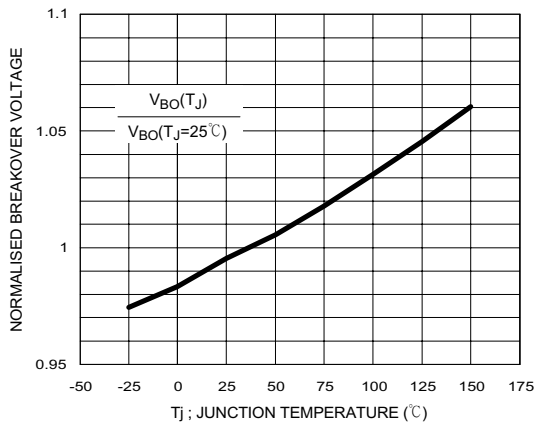

Fig.4 - On-State Current v.s On-State Voltage

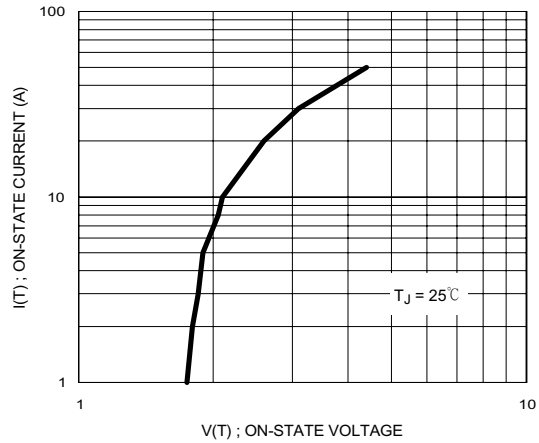

Fig.5 - Relative Variation of Holding Current v.s Junction Temperature

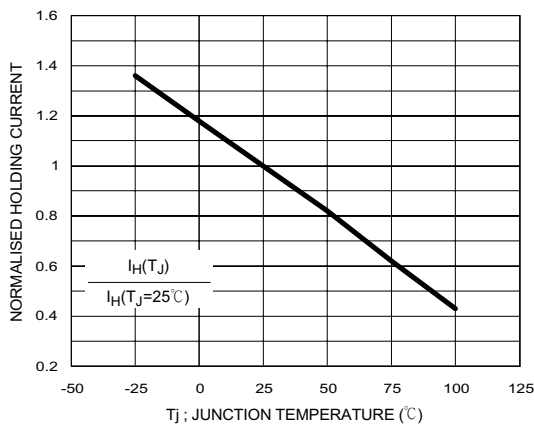
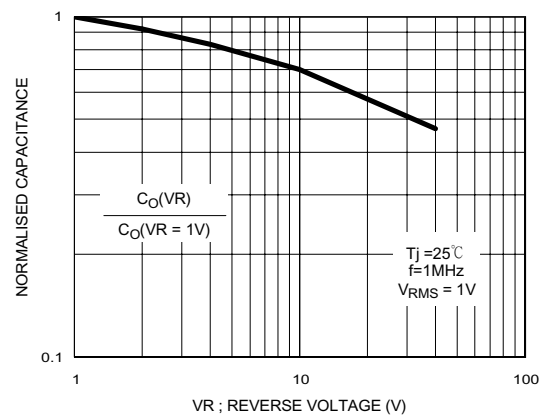
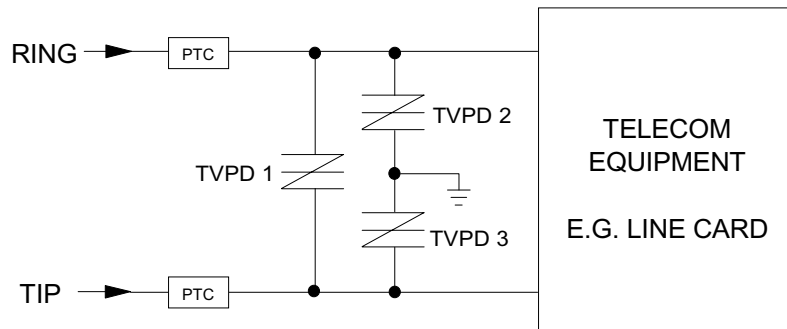
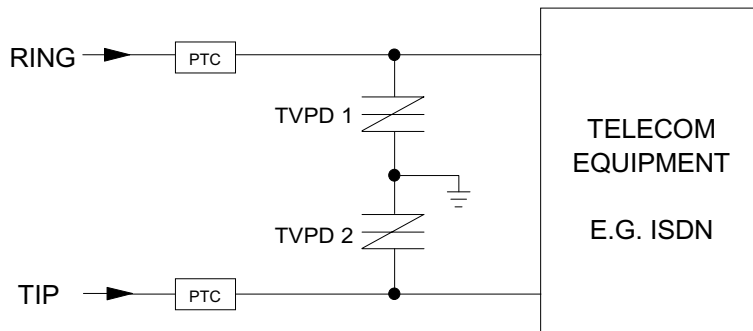
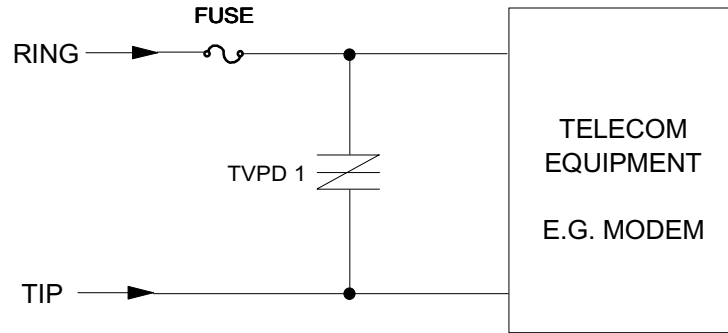

Fig.6 - Relative Variation of Junction Capacitance v.s Reverse Voltage Bias



TSMBJ0505C-064

TYPICAL APPLICATION CIRCUITS



The PTC (Positive Temperature Coefficient) is an overcurrent protection device.